

# Electromax V+ Controller Wiring Diagrams

## 2-4.2 Terminal Board Wiring Diagrams

### Line Voltage.

NOTE: THE SOURCE SHOULD HAVE ITS NEUTRAL SIDE GROUNDED.  
IF THIS IS NOT POSSIBLE, USE AN ISOLATION TRANSFORMER  
IN THE SUPPLY LINE AND GROUND THE SIDE OF THE SECONDARY  
CONNECTED TO TERMINAL T83-2.

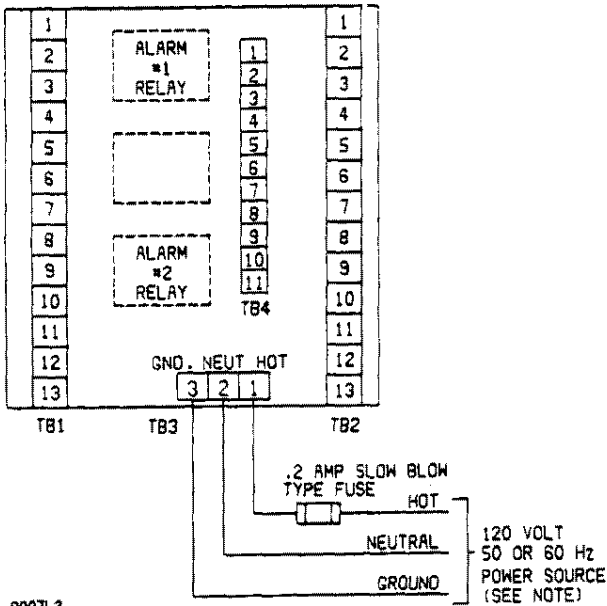

Fig. 2-4.1—Line voltage connections when catalog Suffix D=1

NOTE: THE SOURCE SHOULD HAVE ITS NEUTRAL SIDE GROUNDED.  
IF THIS IS NOT POSSIBLE, USE AN ISOLATION TRANSFORMER  
IN THE SUPPLY LINE AND GROUND THE SIDE OF THE SECONDARY  
CONNECTED TO TERMINAL T83-2.

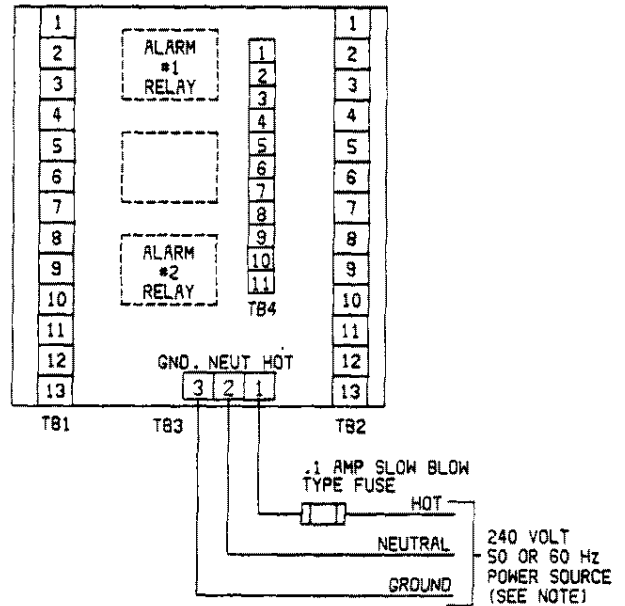

Fig. 2-4.2—Line voltage connections when catalog Suffix D=2.

# Electromax V+ Controller

## Wiring Diagrams

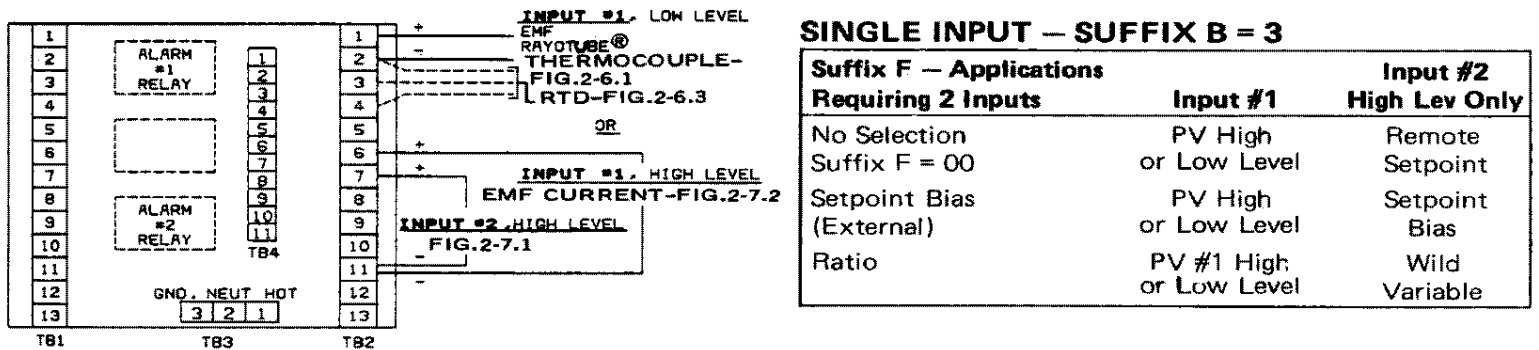

Fig. 2-5.1—Input connections possible when catalog Suffix B=3 (nonisolated).

### DUAL INPUT – NON-ISOLATED – SUFFIX B = 4

Suffix F – Applications Requiring 2 or 3 Inputs	Input #1	Input #2 High Lev Only	Input #3 High Lev Only
No Selection Suffix F = 00 Back-Up Control Output Tracking	PV High or Low Level	Remote Setpoint	Output Tracking Input
Summer (on PV)	PV #1 High or Low Level	Setpoint Bias or Remote Setpoint	PV #2
Setpoint Bias (Summer on Setpoint)	PV High or Low Level	Remote Setpoint	Setpoint Bias
Ratio	PV #1 Cont. Variable - High or Low Level	Wild Variable	Bias Input N/A
Ratio with Setpoint Bias (External)	PV #1 Cont. Variable - High or Low Level	Wild Variable	Bias Input
Feedforward	PV High or Low Level	Remote Setpoint	Feedforward Signal
Mass Flow	Temp High or T.C. Low Level	Diff. Press.	Pressure

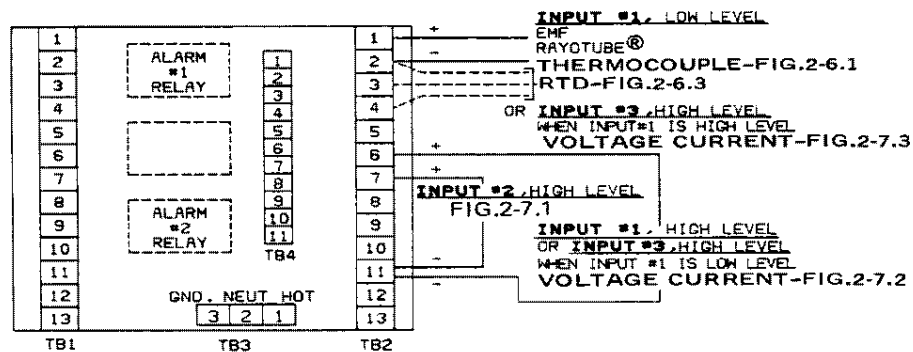

Fig. 2-5.2—Input connections possible when catalog Suffix B=4 (nonisolated).

# Electromax V+ Controller

## Wiring Diagrams

### DUAL INPUT — ISOLATED LOW LEVEL SUFFIX B = 5

Suffix F — Applications Requiring 2 or 3 Inputs	Input #1	Input #2 High Lev Only	Input #3 High Lev Only
No Selection Suffix F = 00 Back-Up Control Output Tracking	PV Isolated Low Level	Remote Setpoint	Output Tracking Input
Summer (on PV)	PV #1 Isolated Low Level	Remote Setpoint or Setpoint Bias	PV #2
Setpoint Bias (External)	PV Isolated Low Level	Remote Setpoint	Setpoint Bias
Ratio	PV #1 Cont. Variable - Isolated Low Level	Wild Variable	Bias Input N/A
Ratio with Setpoint Bias (External)	PV #1 Cont. Variable - Isolated Low Level	Wild Variable	Bias Input
Feedforward	PV Isolated Low Level	Remote Setpoint	Feedforward Signal
Mass Flow	Temp Isolated T.C. Low Level	Diff. Press.	Pressure

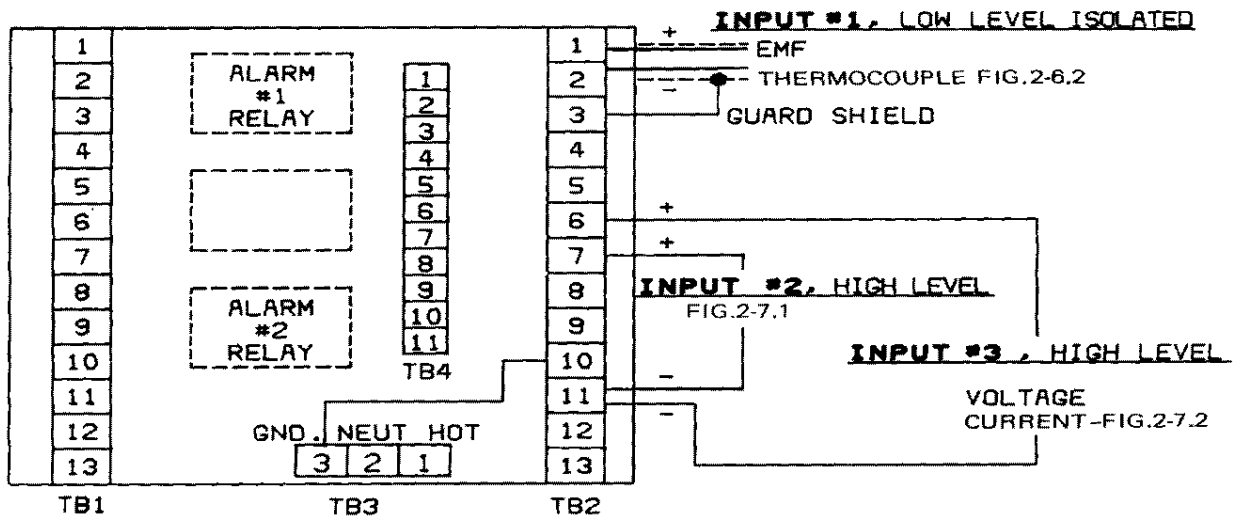

Fig. 2-5.3—Input connections possible when catalog Suffix B=5 (input #1 isolated).

# Electromax V+ Controller

## Wiring Diagrams

### Low Level Input #1 Connections.

If input is a thermocouple, use the appropriate extension leadwire. If input is an RTD, A and B leads must be of equal resistance.

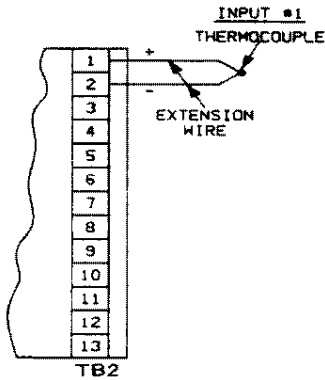

**Fig. 2-6.1—Input #1 low level: thermocouple (nonisolated).**

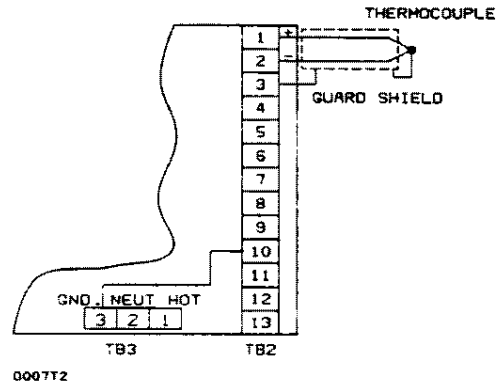

**Fig. 2-6.2—Input #1 low level: thermocouple (isolated).**

### ISA COLOR CODES—EXTENSION WIRES

Thermocouple		Wire Insulation Color Code		
		Positive (+)	Negative (-)	Overall
Duplex Extension Wires	Iron-Constantan (J)	Iron: White	Constantan: Red	Black
	Nickel, Chromium-Nickel, Aluminum (K)	Nickel, Chromium: Yellow	Nickel, Aluminum: Red	Yellow
	Copper-Constantan (T)	Copper: Blue	Constantan: Red	Blue
	Platinum, Rhodium-Platinum (R, S)	Copper: Black	#11 Alloy: Red	Green
	Nicrosil-Nisil (N)	Nicrosil: Orange	Nisil: Red	Orange
Single Conductors	Iron-Constantan (J)	Iron: White	Constantan: Red White Tracer	—
	Nickel, Chromium-Nickel, Aluminum (K)	Nickel, Chromium: Yellow	Nickel, Aluminum: Red, Yellow Tracer	—
	Copper-Constantan (T)	Copper: Blue	Constantan: Red, Blue Tracer	—
	Platinum, Rhodium-Platinum (R, S)	Copper: Black	#11 Alloy: Red Black Tracer	—
	Nicrosil-Nisil (N)	Nicrosil: Orange	Nisil: Red	—
Nickel, Chromium-Constantan (E)	Nickel, Chromium: Yellow	Constantan: Red	—	

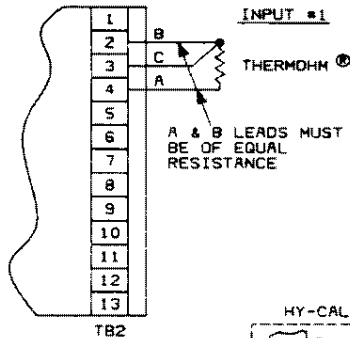

**Fig. 2-6.3—Input #1 low level: resistance temperature detectors — RTD.**

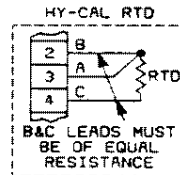

# Electromax V+ Controller

## Wiring Diagrams

### PART II

#### Input #2

These connections are shown in Fig. 2-7.1. Select either 0 to 4 or 1 to 5 volts dc by selecting the appropriate configuration, CF3. If 4 to 20 mA remote set point signal is used, connect 250 ohm, 0.1% resistor between TB2 terminals 7 and 11 as shown in the figure. If the 0 to 16 mA input signal is used, select the 0 to 4 V input range by configuring CF-3.

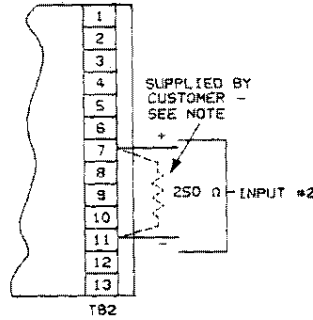

**Fig. 2-7.1—Input #2: voltage or current.**

NOTE: FOR CURRENT INPUT MOUNT RESISTOR AS SHOWN. FOR VOLTAGE INPUT OMIT RESISTOR.

000771

#### High Level Input #1 Connections.

These connections are shown in the basic input connections, Fig. 2-5.1. For high level current input of 4 to 20 mA, connect the 250 ohm, 0.1% resistor supplied between TB2 terminals 6 and 11 and select the 1 to 5 volt input range. If the 0 to 16 mA input signal is used, select the 0 to 4 V input range by configuring CF-3.

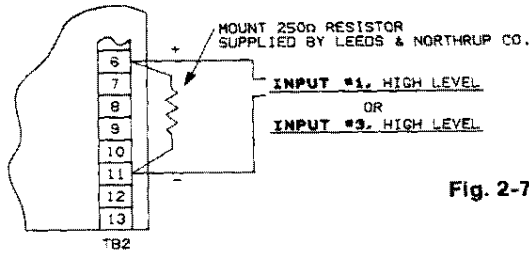

**Fig. 2-7.2—Input #1 (includes Fiberay) or input #3: high level current input.**

000774

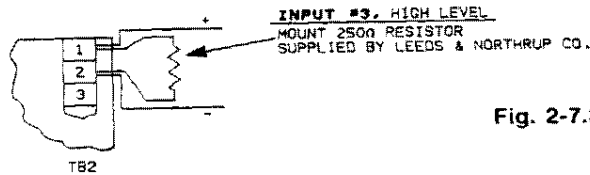

**Fig. 2-7.3—Input #3: high level current input.**

000775

# Electromax V+ Controller

## Wiring Diagrams

### C.A.T. Output

The 4 to 20 mA output can be converted to 0 to 20 mA into 600 ohms or less, 1 to 5 mA into 2400 ohms or less, or 0 to 5 mA into 2400 ohms or less. Isolation between input and output is present when Suffix B = 5 (input isolation) is included.

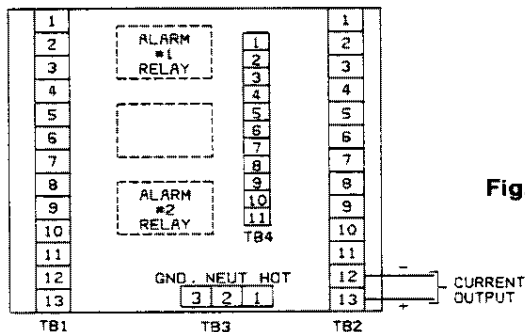

Fig. 2-8.1—C.A.T. output.

0007T6

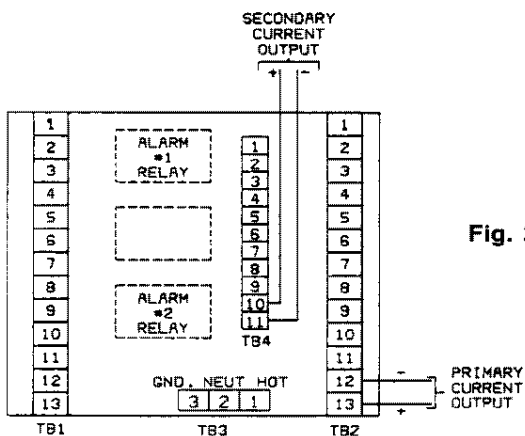

Fig. 2-8.2—Dual control output  
Primary — C.A.T.  
Secondary — C.A.T.

0007T7

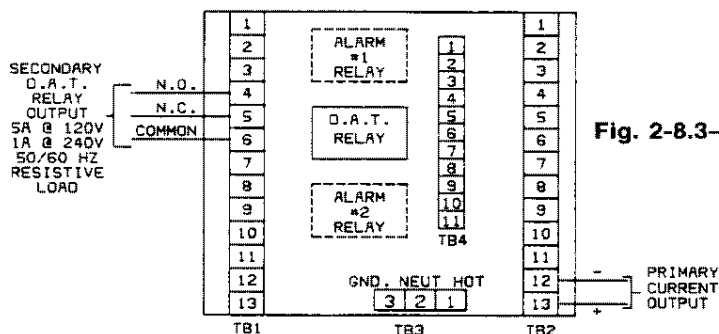

Fig. 2-8.3—Dual control output  
Primary — C.A.T.  
Secondary — D.A.T. (relay).

0007T8

# Electromax V+ Controller

## Wiring Diagrams

### PART II

#### D.A.T. Output

**Relay output.** Contacts are rated at 5 amperes, 120 volts or 1 ampere at 240 volts, 50/60 Hz, for a resistive load. See Fig. 2-9.1

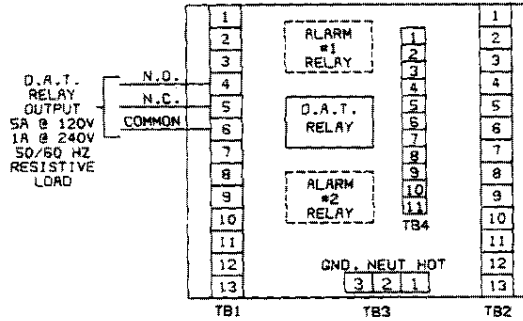

Fig. 2-9.1—D.A.T. relay output.

D007T9

**Triac output.** 100 mA to 10 amperes at 120 volts, 50/60 Hz. See Fig. 2-9.2

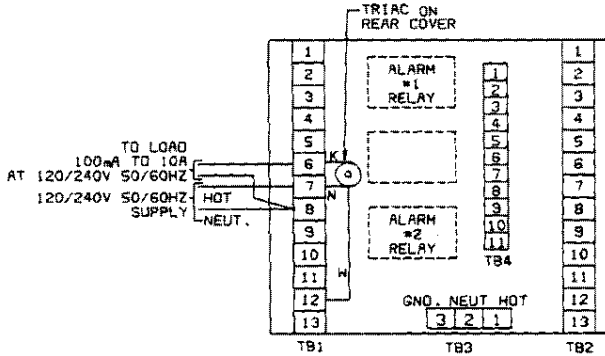

Fig. 2-9.2—D.A.T. triac output.

D007Z1

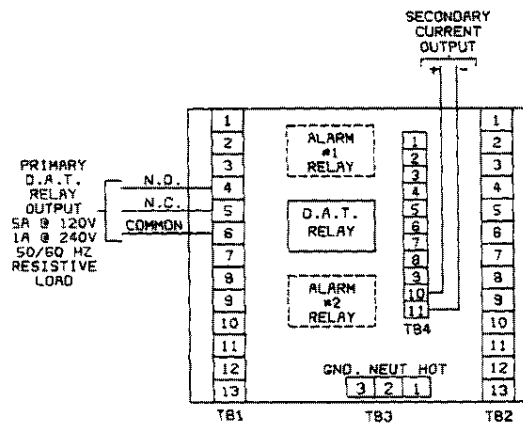
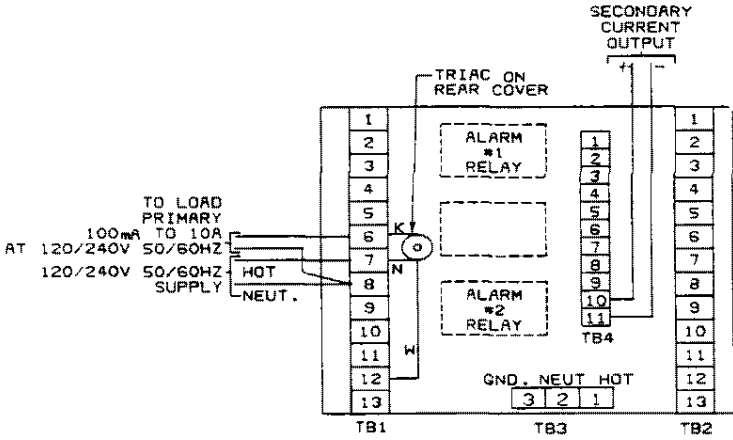

Fig. 2-9.3—Dual control output  
Primary — D.A.T. (relay)  
Secondary — C.A.T.

D007Z2

# Electromax V+ Controller

## Wiring Diagrams



000723

**Fig. 2-9.4—Dual control output**  
**Primary — D.A.T. (triac)**  
**Secondary — C.A.T.**

Each triac output 50 mA to 1A at 120 V, 50/60 Hz.

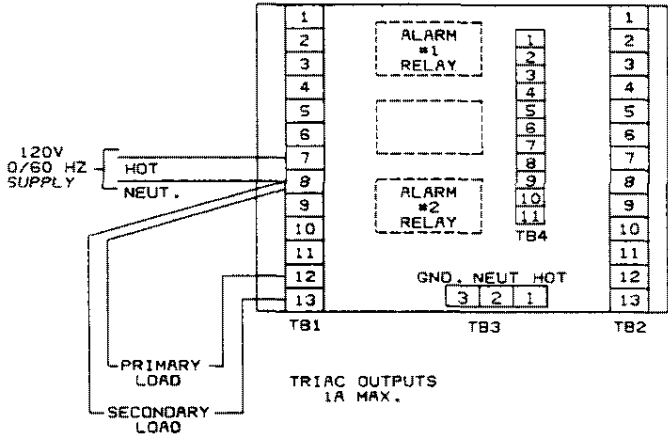

000724

**Fig. 2-9.5—Dual control output**  
**Primary — D.A.T. (triac)**  
**Secondary — D.A.T. (triac).**

# Electromax V+ Controller Wiring Diagrams

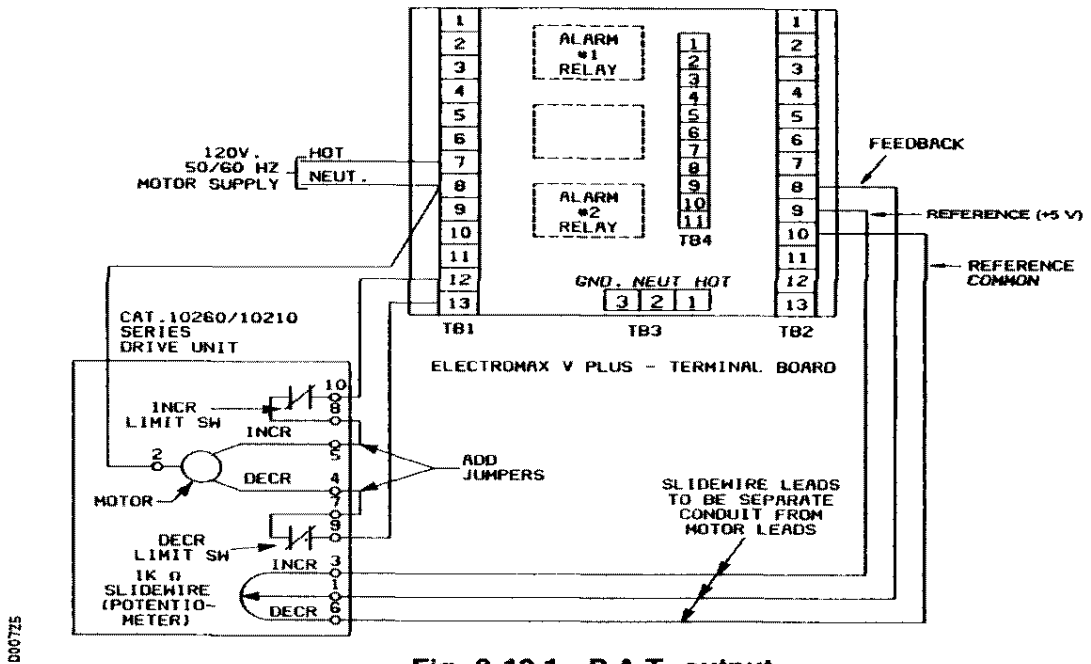

Fig. 2-10.1—P.A.T. output.

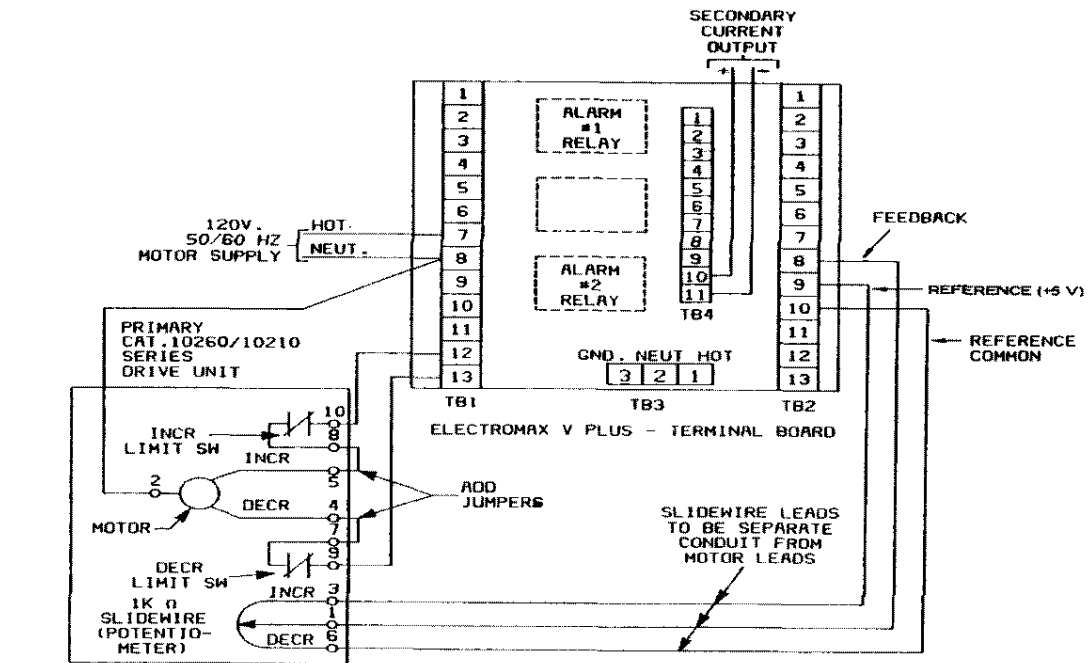
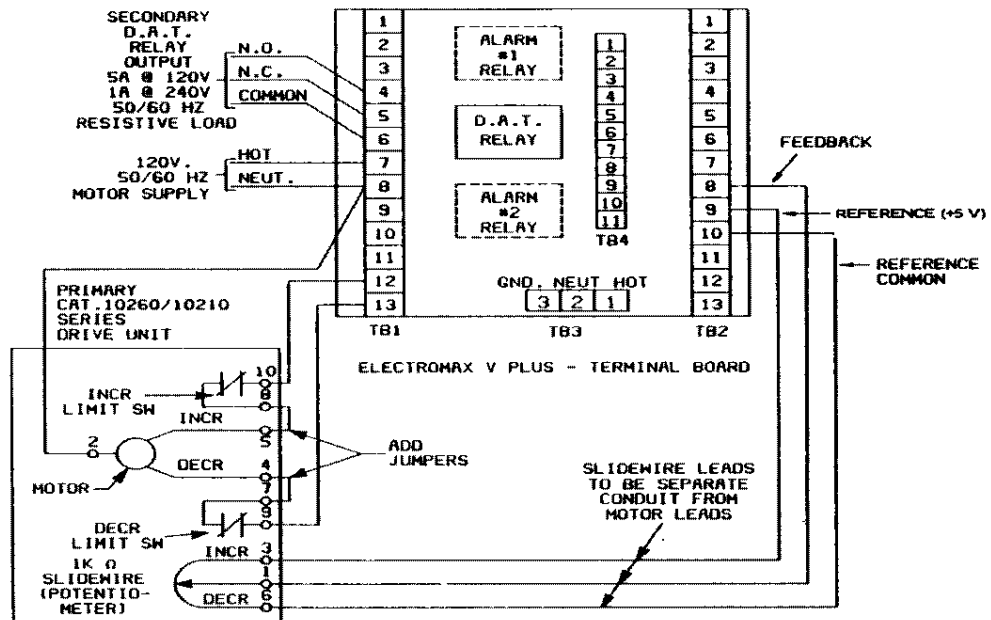

Fig. 2-10.2—Dual control output  
Primary — P.A.T.  
Secondary — C.A.T.

# Electromax V+ Controller Wiring Diagrams



000727

**Fig. 2-10.3—Dual control output  
Primary — P.A.T.  
Secondary — D.A.T. (relay).**

# Electromax V+ Controller Wiring Diagrams

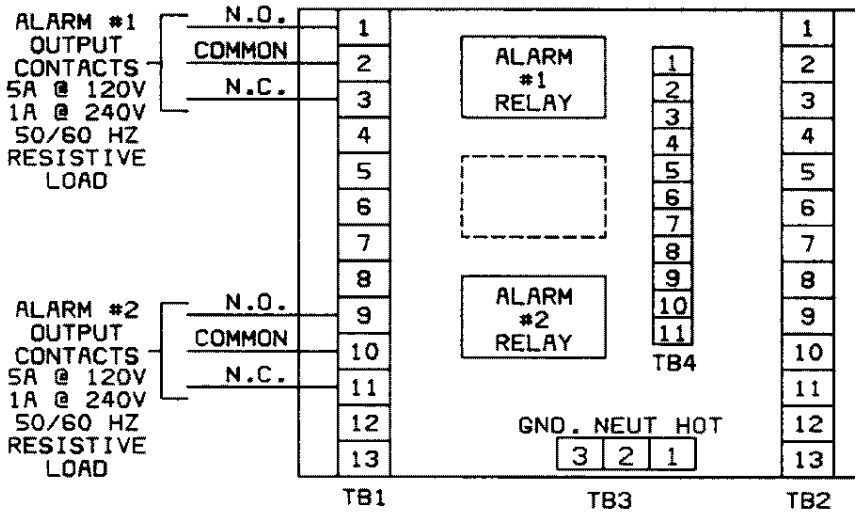

### Alarm Output

Contacts are rated for 5 amperes at 120 volts or 1 ampere at 240 volts, 50/60 Hz resistive load. The alarm "sense" is determined by the direction of the process variable alarm trip.

D007Z8

Fig. 2-10.4—Alarm relays.

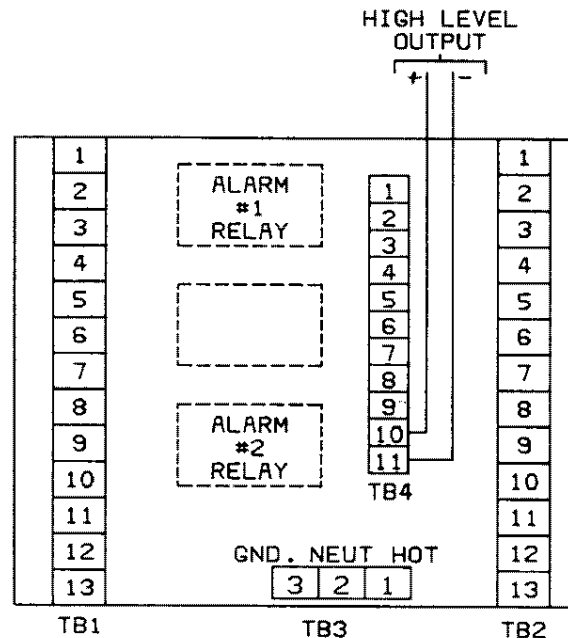

### High Level Output (Option 103)

A 4 to 20 mA output can be converted to a 0 to 20 mA into 600 ohms or less, or 1 to 5 or 0 to 5 mA into 2400 ohms or less.

D007Z9

Fig. 2-10.5—High level output.

# Electromax V+ Controller Wiring Diagrams

## Discrete Digital Input Connection

These connections are shown, using both external 12 volts, in Fig. 2-11.1 and internal 12 volts, in Fig. 2-11.2.

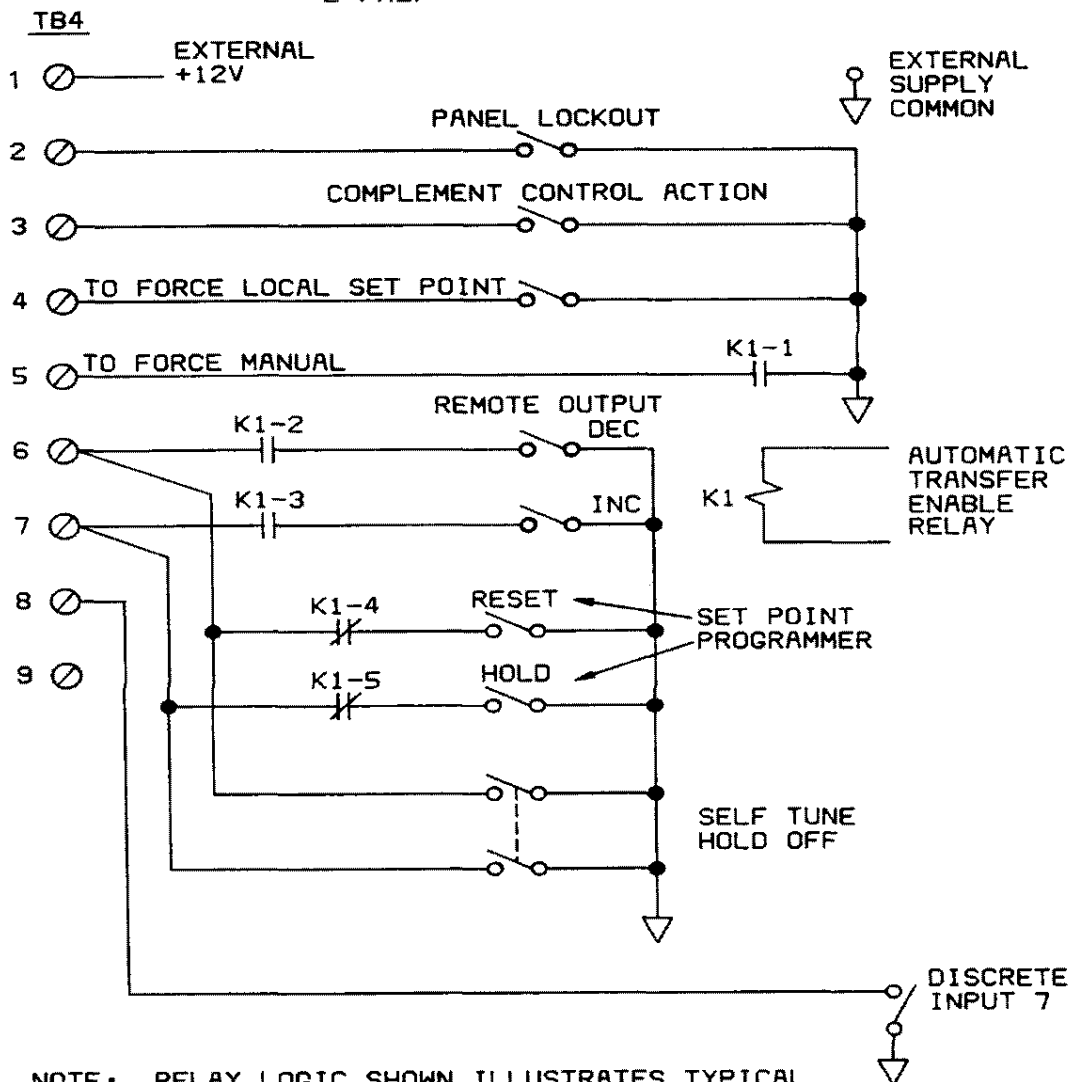

**NOTE:** RELAY LOGIC SHOWN ILLUSTRATES TYPICAL INTERLOCK SCHEME TO MAKE MAXIMUM USE OF AUTO/MANUAL, SET POINT PROGRAMMER AND SELF TUNE REMOTE FUNCTION CONTROL.

D086A1

**Fig. 2-11.1—Discrete digital input connections using external +12 V supply.**

# Electromax V+ Controller Wiring Diagrams

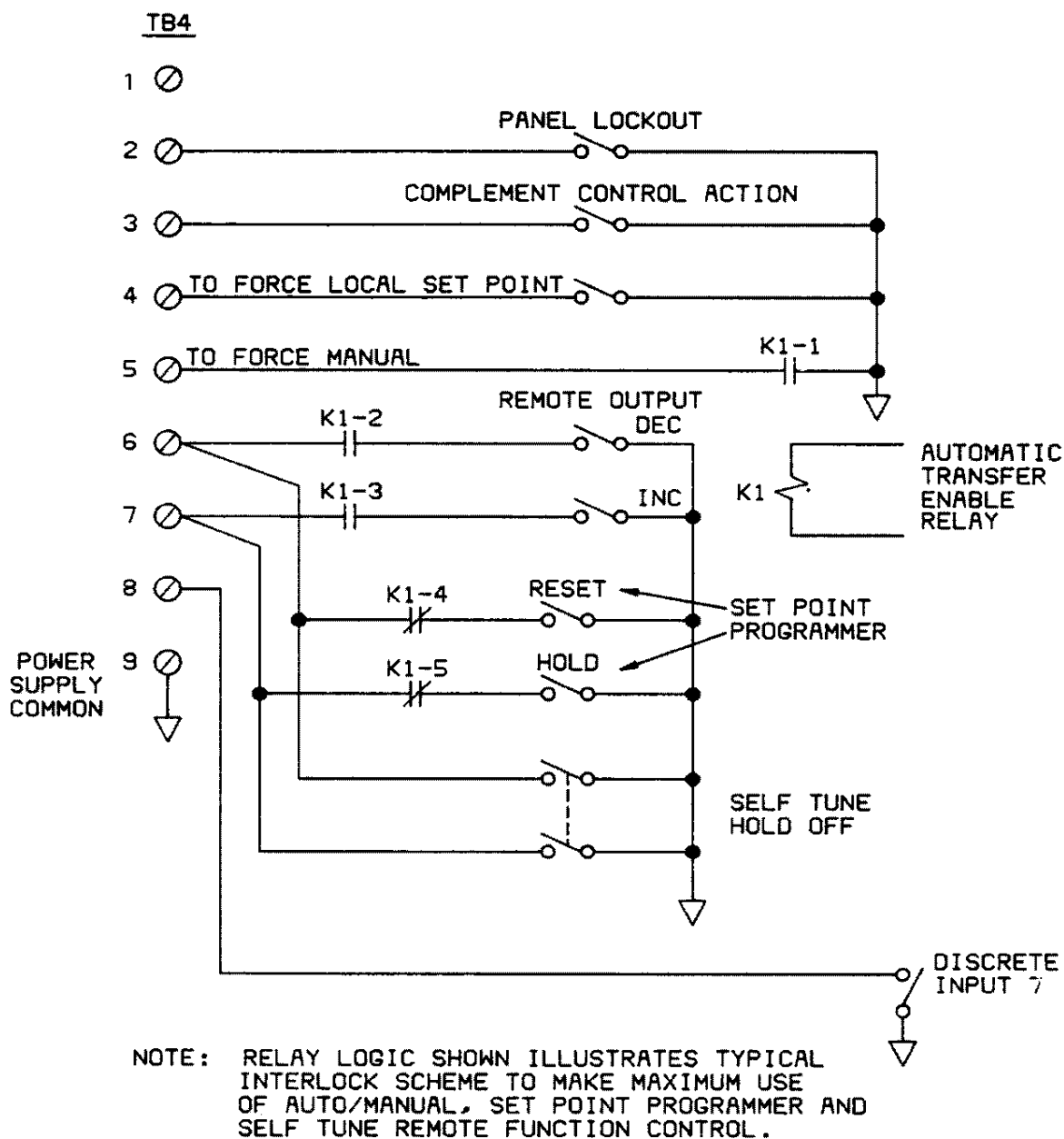

D086A2

**Fig. 2-11.2—Discrete digital input connections using internal isolated +12 V supply.**