

EV+ Controller

Calibration Function Descriptions

Calibration functions are accessed from the Selection (SEL) Menu display. The key sequence must start from manual (light on). Press PRGM SELECT and the F series comes up. Now press RMT/LCL and the selection menu (SEL) is displayed. Press PRGM SELECT until SEL CAL comes up. Press ENTER. The procedure from this point on is described by the flow chart in this section.

Certain analog calibrations C1, C5, C6, and C7 require the connection of a specified source to the terminals on TB2 of the rear panel. The right display blanks when these are entered. When the routine is entered by the proper key sequence, scale factors are computed and stored in the nonvolatile memory. These factors are used to correct measured data for gain and offset errors. Digital calibrations require that a displayed quantity be set using the INCR or DECR keys, and then stored.

FUNCTION DESCRIPTION

C1-H	ADC Calibration; 5 Volts
	Requires a precision calibrating voltage input of $5 \pm .0025$ volts at terminals 7 (+) to 11 (-). The calibrating voltage source must be accurate to $\pm .05\%$.
C1-L	ADC Calibration; 1 Volt
	Requires a precision calibrating voltage of $1 \pm .0005$ volts.
C2	CAT Output
	An internal reference voltage is used to make this calibration. C2 calibrates the digital to analog converter on the current output board.
*C3	Primary Output Slew Time
	Minimum time in seconds required to full-stroke the final control element. C3 must never be set to zero.
C4-H	Set Point; Hi Limit
	The restricting high limit of the set-point range. Note: Because this setting is based upon the scaling of Input #1, which is set by using Function C8, always make C8 settings before making C4 settings if variable scaling is used.
C4-L	Set Point; Low Limit
	Restricting low limit of the set-point range. (This value may be set to minus (-) the full set point span for bias operation.)
*C5-H	PAT Feedback Calibration; Hi Limit
	Note that this setting requires that drive-unit sensitivity setting, F9, be set to 100. This setting establishes the high end of the drive-unit feedback slidewire range. The drive-unit connections to TB2 terminals 8, 9, and 10 are completed and the drive unit is run to its high-end limit. A voltage is displayed in the right display. The high end of the range is entered in the controller when DECR and INCR are pressed simultaneously.
*C5-L	PAT Feedback Calibration; Lo Limit
	This setting establishes the low end of the drive unit feedback slidewire range.

* These calibration functions must be set at startup. Other functions may also have to be set at startup, depending upon your applications and features.

EV+ Controller

Calibration Function Descriptions

C6-H Low-Level Input #1 Calibration; High End

C6-L Low-Level Input #1 Calibration; Low End

This calibration requires an adjustable millivolt calibrating source for a thermocouple or millivolt range as listed in the Range Table (Appendix A). Use copper wire. It requires an adjustable precision resistance input (with one milliohm setability) to simulate the input resistance thermometer for an RTD range. C6-H is set to the value at the high end of the range as listed in the Range Table in Appendix A; C6-L is set to the low-end value.

C7 Thermocouple Reference Junction Compensation

This setting requires that the thermocouple-input terminals (1 and 2 on TB2) be shorted out, the temperature measured at the terminal board and this temperature value displayed by using INCR and DECR keys. If large temperature gradients exist which do not permit accurate measurement of the temperature of the connecting block, use thermocouple extension wire matched to the TC range and short these together away from the terminal board and measure the temperature at the TC junction.

C8-d Scaling of Input #1; decimal

C8-H Scaling of Input #1; High End

C8-L Scaling of Input #1; Low End

This CAL function is used to establish the process variable display range in engineering units (such as degrees temperature, cubic feet per minute, etc.) for Input #1. Note that if C4 was already set, it must be set again after C8 is adjusted. With C8-d displayed, the decimal point is shifted to the appropriate position using INCR or DECR. Then the desired C8-H and C8-L values (representing the high end and low end respectively). The value of this input can be viewed by calling up d1 in the dSPL series. Spans should not exceed 5000 counts. This function is not used for low level nonlinear ranges.

C9 Rayotube Emissivity Compensation

This CAL function will not be displayed if the Rayotube range module is not in place.

C10-d Scaling of Input #2; decimal

C10-H Scaling of Input #2; High End

C10-L Scaling of Input #2; Low End

Used with Application Package A or B to establish the #2 input display range in engineering units such as degrees temperature, flow unit, etc. In the active display series, Input #2 can be viewed by calling up d2 in the dSPL display. Using INCR and DECR, C10-d is set for the decimal point, C10-H and C10-L values are set to represent the high end and low end, respectively, of the high level input #2.

C11-d Scaling of Input #3; decimal

C11-H Scaling of Input #3; High End

C11-L Scaling of Input #3; Low End

Used with Application Package A or B to establish the #3 input display range in engineering units. In the active display series, this can be viewed by calling up d3 in the dSPL display. Using INCR and DECR, C11-d is set for the proper decimal point, C11-H and C11-L values are set to represent the high end and low end, respectively, of the high level Input #3.

EV+ Controller

Calibration Function Descriptions

C12-d Scaling of the Computational Algorithm; decimal

C12-H Scaling of the Computational Algorithm; High End

C12-L Scaling of the Computational Algorithm; Low End

Used with Application Package A to establish the range of the mass flow or other computational output in engineering units. Using INCR and DECR, C12-d is set for the proper decimal position; then C12-H and C12-L values are set to represent the high and low end, respectively, of the computed output. The method for determining the range of output values in order to set C12 is described under *Application Packages in Part XI*. The scaled value of this function is viewed as PV in the normal operating display.

C13 Auxiliary Output Calibration

This calibration establishes the auxiliary output digital to analog converter calibration. No external source is needed. The jumper on the mother board must be moved from E15-E16 to E14-E15 position before this calibration is performed.

C14-H Primary C.A.T. Output Scaling; High End

C14-L Primary C.A.T. Output Scaling; Low End

Establishes the range of the current output in percent of the basic current output range established by Configuration Function CF-3 and output card jumper. C14-H is set at 100% and C14-L is set at 0% when shipped. See output scaling in Part VIII.

C15-H Secondary C.A.T. Output Scaling; High End

C15-L Secondary C.A.T. Output Scaling; Low End

This CAL function serves to establish the C.A.T. output taken from auxiliary output terminals on TB4 when a #2 C.A.T. output board is in place. It is set in percent of the current output range configured by CF-4. This auxiliary output is assigned to process variable, set point, deviation, or an option supplied as selected in CF-4. See output scaling in Part VIII.

C16 Secondary Output Slew Time

Minimum time in seconds to full stroke the second final control element.

C16 must never be set to zero.

EV+ Controller Calibration Procedure

The controller has been factory calibrated.

A full recalibration is **not** necessary to place the controller in service. Only selected C-Functions indicated by a star are needed for startup and these are covered in the appropriate startup procedures. All of the calibration functions are included in this chart as required for normal maintenance or following instrument servicing. It usually is not necessary to act on every function in the chart. Press PRGM SELECT until the particular group of C functions of interest is displayed; then follow the chart procedure.

Note that the controller must be on manual operation in order to access these functions. When necessary to exit the C-Function level, press CLEAR. Note that this is necessary before powering down (or removing the chassis) as is necessary before jumper changes needed for certain C-Function settings. Failure to press CLEAR will cause the loss of all C-Function settings entered.

Where the DECR and INCR keys are enclosed in a block on this chart, they must be pressed together.

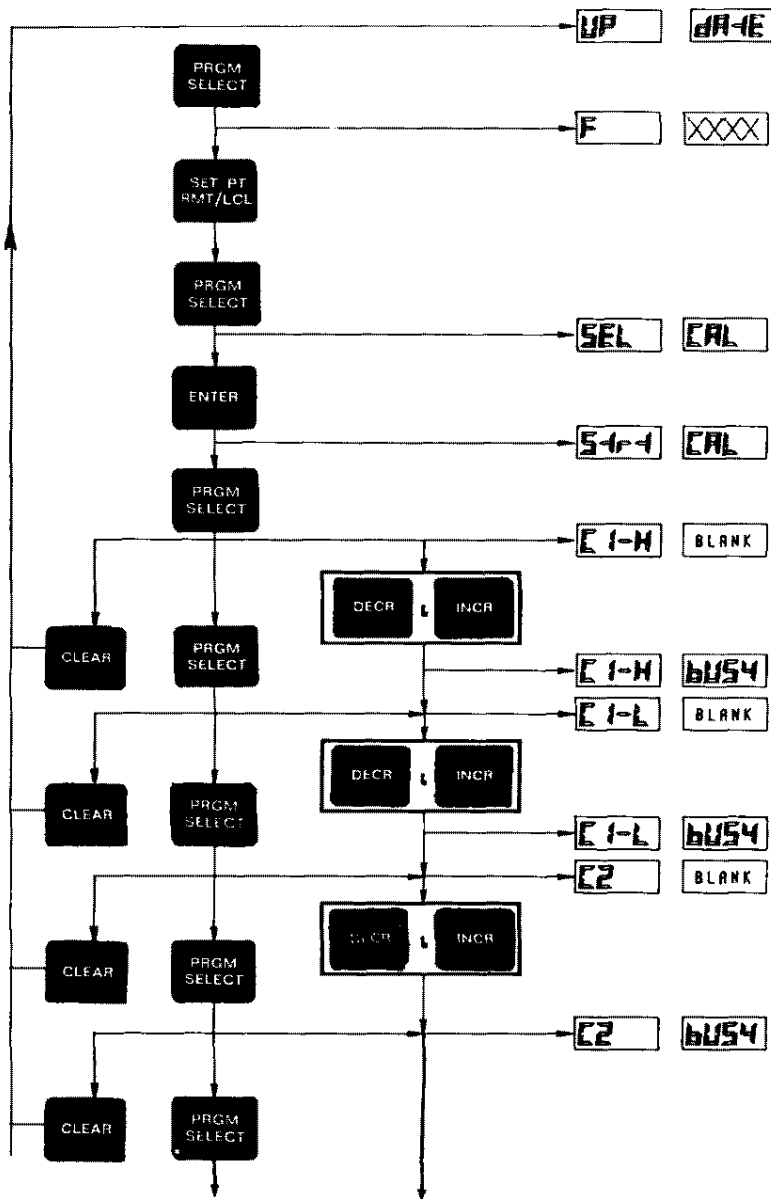

Calibration Sequence

To start the sequence, first transfer to manual operation by pressing the auto/man symbol. Then follow the touch-switch column. Calibration functions needed for start up are marked with an asterisk.

ADC Calibration

High End

Connect precision 5 V ± .05% source to remote setpoint input, terminals 7 (+) to 11 (-) on the right terminal strip, TB2.

Low End

Adjust precision source to 1 V ± .05%.

DAC Calibration (For C.A.T. Control Only)

No. 1 C.A.T. Output Board

If an error message comes up, check that the jumper on the Mother Board is in position E15-E16. If auxiliary output is used, calibrate C13 at this time also.

EV+ Controller Calibration Procedure

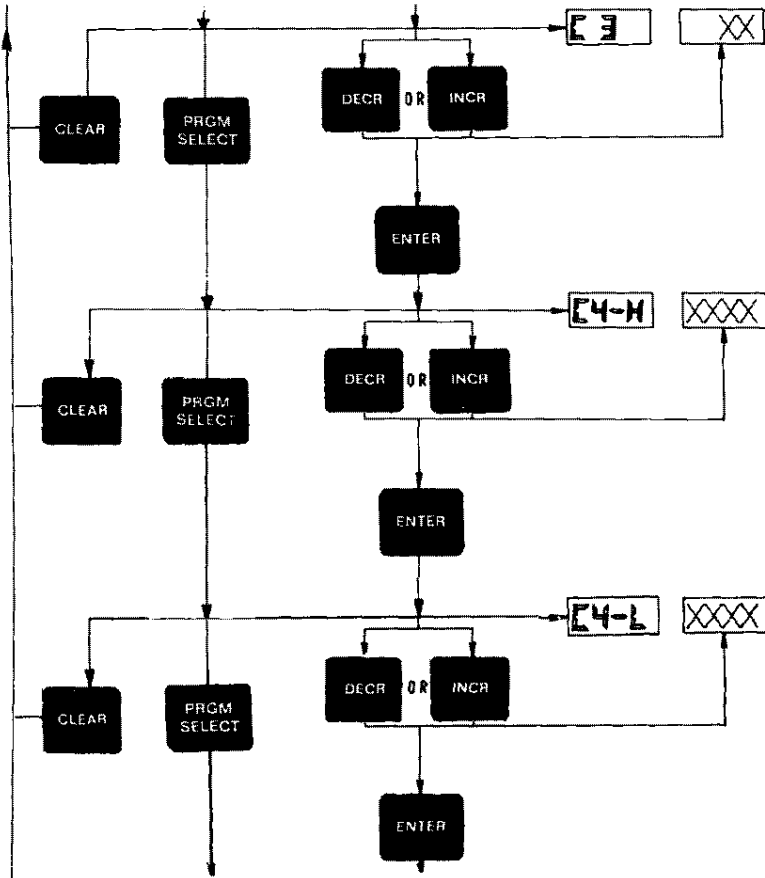

Primary P.A.T. and C.A.T. Output Slew Time

For P.A.T. press INCR or DECR to set the value of XX to your drive-unit-full-stroke time. Then press ENTER and CLEAR.

For C.A.T. enter the minimum time for full output change. **CAUTION:** Do not enter zero if slew is not required, enter OFF.

Set Point Limits

High Limit

Press INCR or DECR to change value XXXX only if you want to restrict the setpoint range to a particular high limit.

Low Limit

Press INCR or DECR to change value XXXX only if you want to restrict the setpoint range to a particular low limit.

EV+ Controller Calibration Procedure

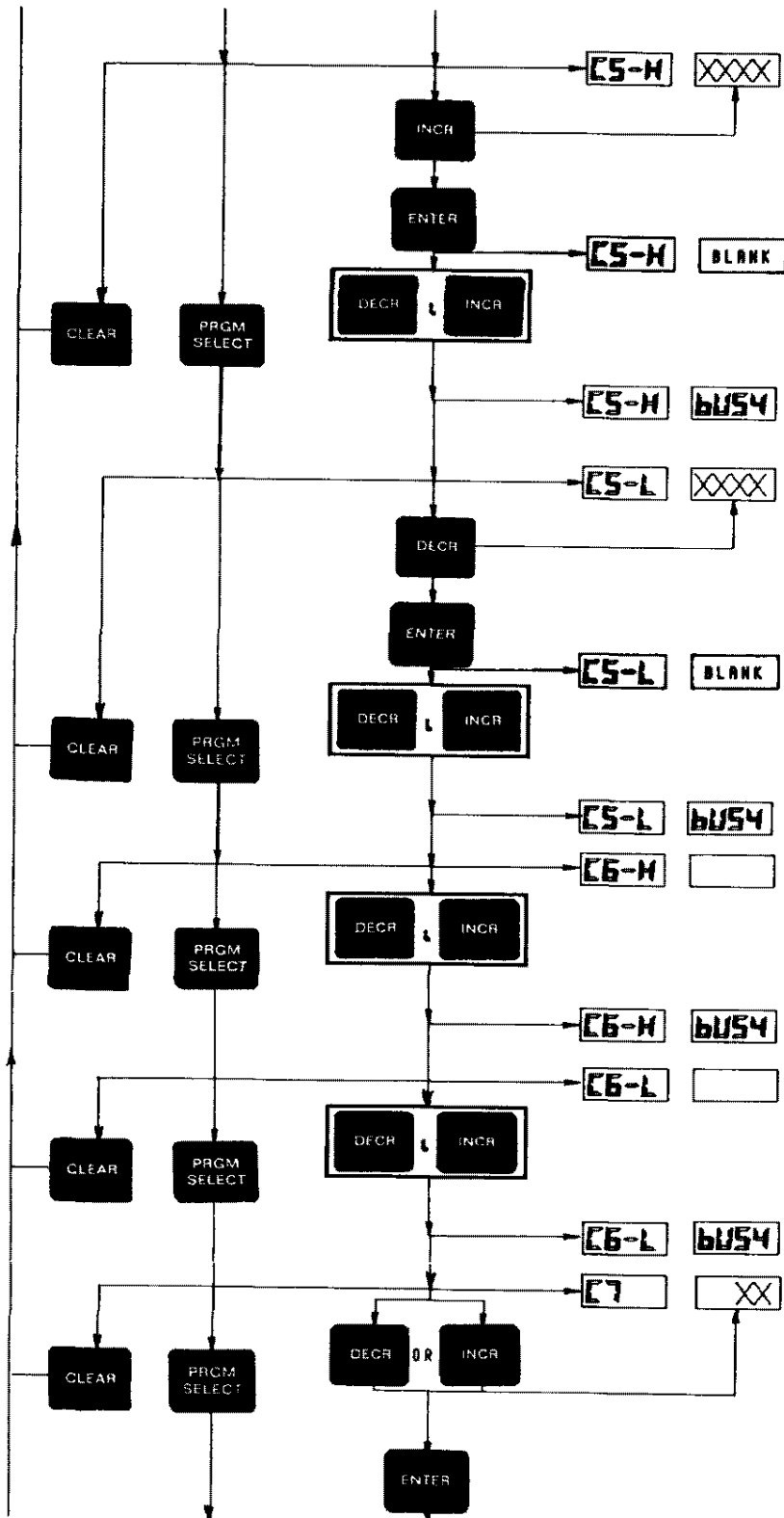

P.A.T. Feedback Calibration

High End

Connections to terminals 8,9, and 10 must be completed and the drive unit sensitivity, Function F9, must be set to 100.

Important: If the C3 value was changed from OFF to a value, you must exit calibration by pressing CLEAR before attempting to calibrate C5. If F9 has not been programmed, the drive unit will not move.

Run the drive unit to its high-end limit (100% output). Display shows about 5 volts.

Low End

Run the drive unit to its low-end limit (0% output). Display shows about 0 volts. **DO NOT enter 0 or a negative voltage.**

Adjust the drive unit end stop if necessary.

Process Variable Input Range Calibration (Low Level)

High End

Using copper wire, connect a millivolt source to the process variable input terminals 1 (+) and 2 (-) on TB2 and adjust it to the high end of the installed input range shown in Appendix A.

Low End

Adjust the millivolt input to the low end of the installed input range shown in Appendix A.

Reference Junction Calibration

Make certain F5 is off. Short out process variable input terminals 1 and 2. Press INCR or DECR to set XX to the temperature measured at the process variable input terminals.

Deselect summer (CF-12 set to 0).

EV+ Controller Calibration Procedure

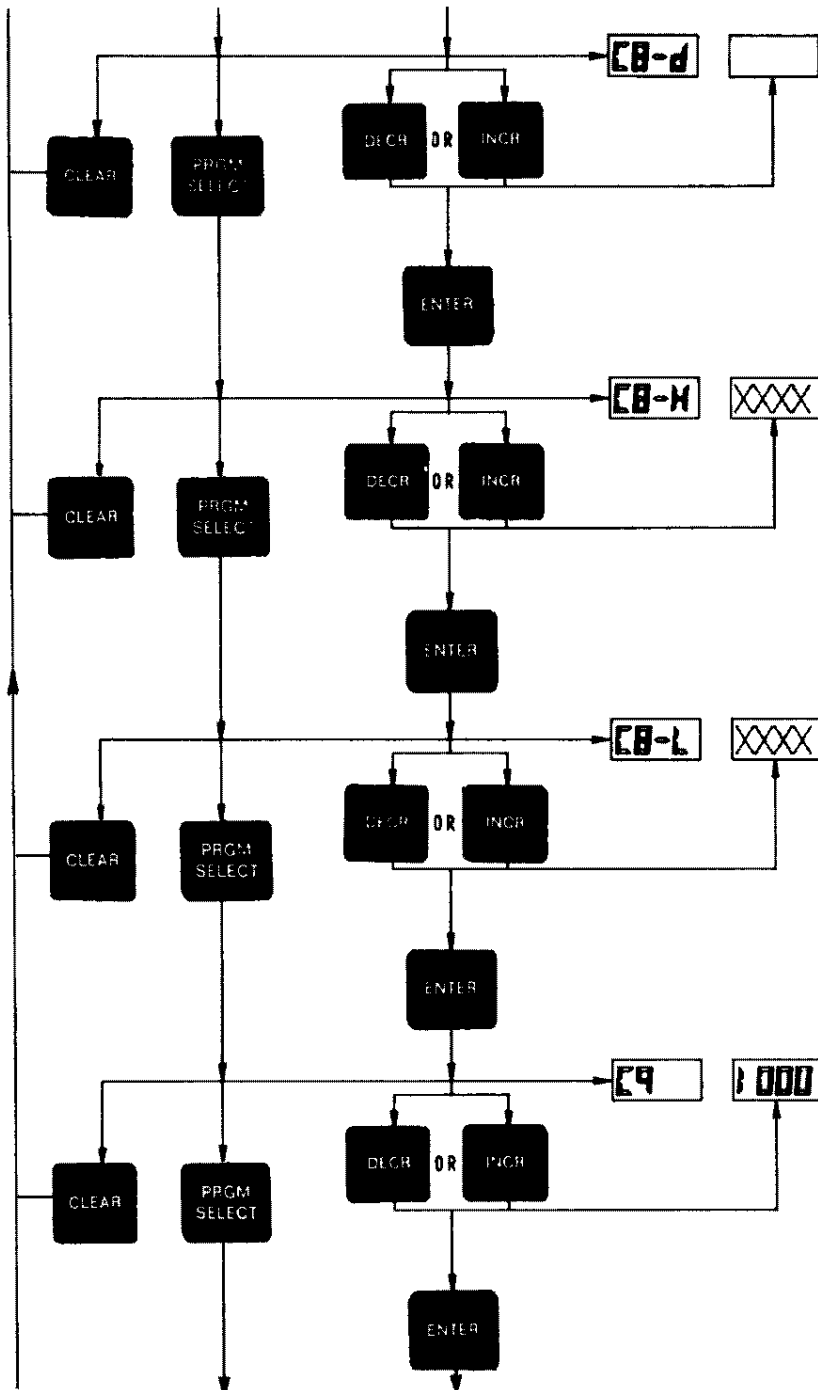

Input #1 Scaling (Linear or High Level Linearized Inputs)

Decimal Point (Linear Only)

Press INCR or DECR to shift decimal point location in display as appropriate for range of values to be displayed. If decimal is changed, reprogram C8-H and C8-L.

High End

Press INCR or DECR to set value of XXXX, process variable value high end.

Low End

Set XXXX to low-end process variable value.

(C9 will be skipped if your range is not for Rayotube)

Emissivity Compensation for Rayotube

If necessary to reset the value, press INCR or DECR to display the known emissivity of the target. To calculate:

$$C9 = \frac{\text{EMF for Displayed PV Value}}{\text{EMF for Actual Target Temp}}$$

Set to 1.000 if Rayotube range is to be recalibrated via C6-H and C6-L.

EV+ Controller Calibration Procedure

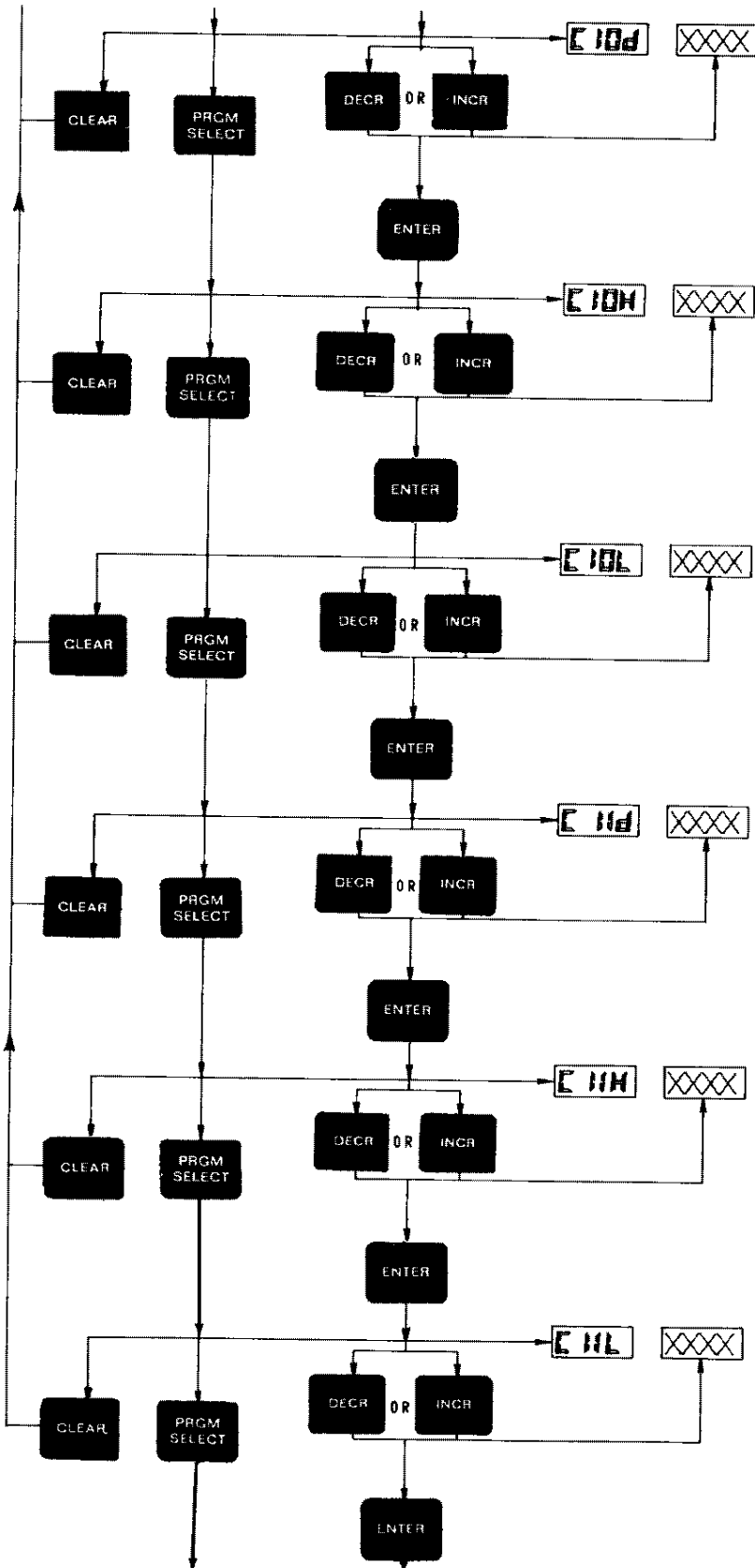

Input #2 Scaling (Remote Set Point Input)

Decimal Point (Application Package A or B)

Press INCR or DECR to shift decimal point location in display as appropriate. If changed, reprogram C10-H and C10-L.

High End

Set value of XXXX to the set point value (in engineering units) for Input #2.

Low End

Set value of XXXX to the set point value (in engineering units) for Input #2. May be 0-4V range.

Input #3 Scaling (Application Package A or B)

Decimal Point

Press INCR or DECR to shift decimal location. If decimal is changed, reprogram C11-H and C11-L.

High End

Set XXXX to the process variable value (in engineering units) for Input #3 high end.

Low End

Set XXXX to the process variable value (in engineering units) for Input #3 low end.

EV+ Controller Calibration Procedure

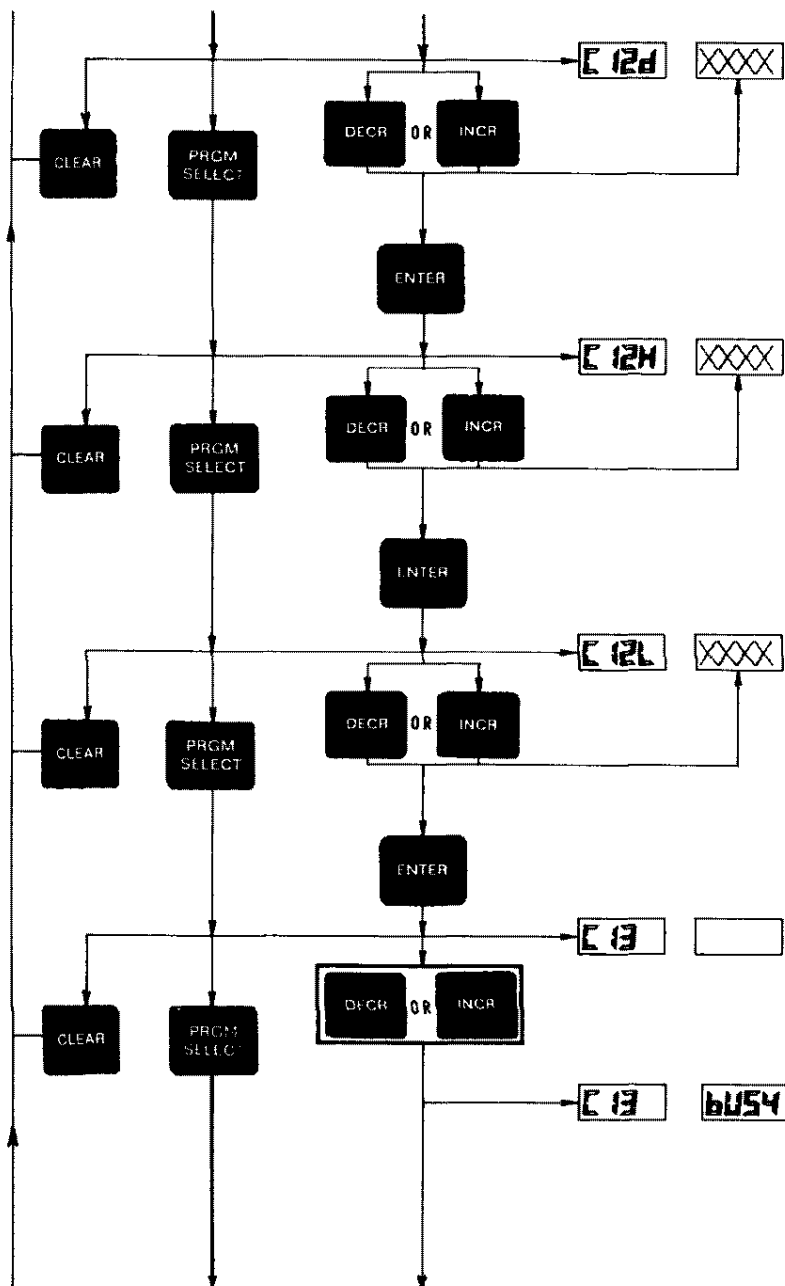

Computational Algorithm Scaling (Application Package A)

(Note that certain options may have fixed values for C12 and will not respond to INCR and DECR keys).

Decimal Point

Press INCR or DECR to shift decimal location in display as appropriate to range of values to be displayed. If decimal is changed, reprogram C12-H and C12-L.

High End

Set XXXX to the value (in engineering units) represented by the output of the mass flow algorithm. This is factory set at 100.

Low End

Set XXXX to the value (in engineering units) represented by the output of the mass flow algorithm. This is factory set at 0.

Auxiliary Output DAC Calibration

CAUTION: Exit the CAL series by pressing clear. Remove line voltage and open the controller. On the Mother Board, move the jumper from position E15-E16 to position E14-E15. If #1 output is P.A.T. control, disconnect the drive unit slidewire from terminal 8 (on TB2).

Restore the controller to operating condition; return to the start of this calibration flow chart, and call up C13. After DECR and INCR are pressed simultaneously and C13 bUSY is displayed, exit the CAL series, remove line voltage, open the controller and return the mother board jumper to position E15-E16. Either return to normal operation or re-enter calibration by returning to the start of calibration flow chart and call up C14 to continue.

EV+ Controller Calibration Procedure

APPENDIX A INPUT #1 — RANGES

SUFFIX C	RANGE MODULE PART NO.		CALIBRATION INPUT SOURCE FOR C6		SENSOR TYPE
Thermocouple		Degrees	Millivolts		
			L	H	
01	046352	120 to 3300 °F (48 to 1816 °C)	0.002	13.763	B Platinum, 6% Rhodium vs Platinum, 30% Rhodium
02	046366	0 to 2500 F (-18 to 1371 °C)	-.69	72.48	Nickel-Nickel Molybdenum
03	046353	-250 to 2000 °F (-157 to 1093 °C)	-6.716	63.39	J Iron vs Constantan
04	046354	0 to 2500 °F (-18 to 1371 °C)	-.692	54.845	K Nickel-Chromium vs Nickel-Aluminum
05	046355	-8 to 2372 °F (-22 to 1300 °C)	-.575	47.502	N Nicrosil/Nisil
06	046356	0 to 3100 °F (-18 to 1704 °C)	-.089	20.275	R Platinum, 13% Rhodium vs Platinum
07	046357	0 to 3200 °F (-18 to 1760 °C)	-.092	18.612	S Platinum, 10% Rhodium vs Platinum
08	046358	-250 to 750 °F (-157 to 399 °C)	-4.794	20.801	T Copper vs Constantan
09	046359	0 to 3980 °F (-18 to 2193 °C)	-.234	35.862	Tungsten, 5% Rhenium vs Tungsten, 26% Rhenium (W5Re/W26Re)
28	064299	-450 to 2200 °F (-268 to 1204 °C)	-9.830	91.814	E Nickel-Chromium vs Constantan
RTD		Degrees	Ohms		
			L	H	
10	046360	-290 to 1500 °F (-179 to 816 °C)	27.484	379.89	100 ohm platinum
11	046361	0 to 1000 °F (-18 to 538 °C)	23.236	74.309	25 ohm platinum
12	046362	-320 to +300 °F (-196 to 149 °C)	12.009	148.093	100 ohm copper
Low-Level Inputs for Variable Scaling by User			Millivolts		
			L	H	
13	046363	0 to 10 millivolts	0	10	—
14	046364	0 to 20 millivolts	0	20	—
15	046365	0 to 100 millivolts	0	100	—
16	046367	-5 to +5 mV	-5	+5	—
High-Level Inputs for Variable Scaling by User					
20	No module	0 to 4 or 1 to 5 volts			—
21	No module	0 to 16 or 4 to 20 milliamps (250 ohm shunt is supplied for terminals 6 to 10 on right side terminal board.)			—