

**Customer's Connection Diagram
for
Model 01026XX-X-1581-XXXXXX1X-XX Actuator (CE)
Auto/Manual Switch, 4 to 20mA Input, 4 to 20mA Output.**

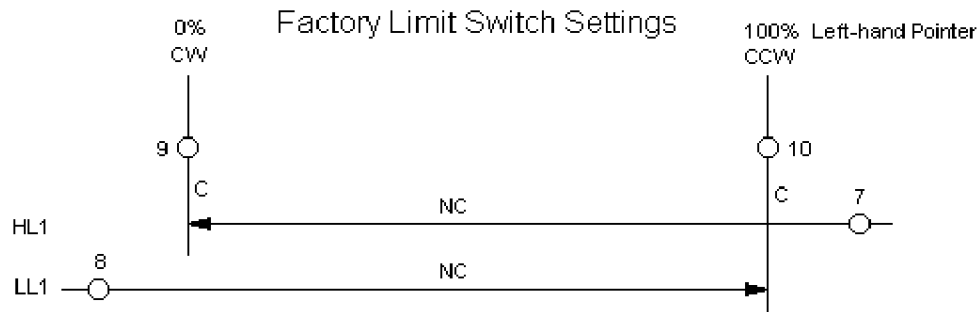

Notes:

1. Clockwise and counterclockwise rotation is the direction of the output shaft when facing the end of the shaft. As shown, clockwise rotation of the output shaft closes the final control device.
2. All external wiring to the actuator must enter through a metal conduit.

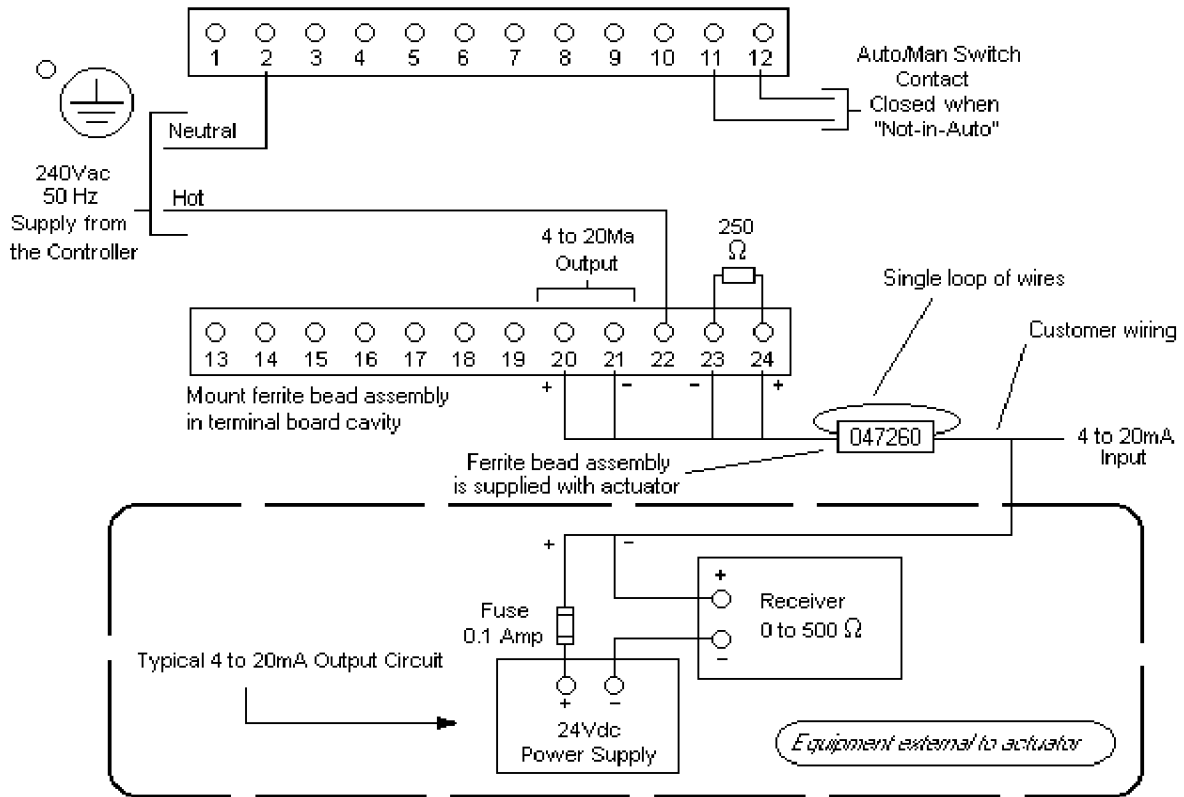

Honeywell

Notes:

1. Available Adjustments for Motor Positioner - For complete procedures see 10260 Series Actuators Installation, Operation and Maintenance Manual 70-82-25-24.

Operating adjustments are located on the printed circuit board accessed by removing casting which covers slidewire/switch compartment. Altogether, there are two jumpers and five potentiometers with the following functions.

Adjustment	Marking	Function
Jumper	W1	Selects fail-safe drive position if drive unit slidewire wiper breaks. Selects full upscale or full downscale. Remove W1 to disable fail-safe feature.
Jumper	W2	Selects fail-safe drive position if input signal is lost. Selects stop, or a particular position determined by R14. Remove W2 to disable fail-safe feature.
Potentiometer	Filter, R1	Input signal filter adjustment.
Potentiometer	Span, R7	Input signal span adjust.
Potentiometer	Zero, R11	Input signal zero adjust.
Potentiometer	Fail-safe Set, R14	Adjusts fail-safe position of drive unit on loss of input signal. Must be enabled by W2.
Potentiometer	D. U. Sens., R19	Adjusts drive unit deadband from 1% to 5%.

2. Connections as shown are for use with left-hand pointer
3. For use with right-hand pointer or projecting scale pointer, make the following changes:

At the actuator terminal board interchange the lead connected to terminal 14 with the lead connected to terminal 15.

At the actuator terminal board interchange the lead connected to terminal 3 with the lead connected to terminal 6 and to reverse the 4 to 20mA output, see 10260 Series Actuators Installation, Operation and Maintenance Manual 70-82-25-24.

If the actuator has a right-hand pointer and a left-hand pointer is desired, make the same changes per notes 1 & 2 above. If appropriate move the mechanical pointer, crank arm and linkage to their correct position.

4. To full stroke the actuator in either direction without a controller:

With the limit switches wired to the motor, connect the neutral side of the 120Vac line to terminal 2 and connect the hot side of the 120Vac line to terminal 9 for CW rotation or terminal 10 for CCW rotation. The motor will run until stopped by its appropriate limit switch. If using 240Vac line connect one side to terminal 2 and the other side to either terminal 9 or 10. Do not energize terminals 9 and 10 simultaneously.

Connections to motor only, connect the neutral side of the 120Vac line to terminal 2 and connect the hot side of the 120Vac line to terminal 4 for CW rotation or terminal 5 for CCW rotation. If using 240Vac line connect one side to terminal 2 and the other side to either terminal 4 or 5. Using this configuration the motor will stall when the output shaft rotation is stopped by the mechanical end stops. Do not energize terminals 4 and 5 simultaneously.

5. Auto/Man switch contact "Not -in-Auto" is rated for a maximum current of 1 amp. at 120Vac non-inductive.

Rev. A Initial Release February 18, 1997

Honeywell