

# HONEYWELL DCP 100/UDC 1000/UDC 100T/UDC 1500/UDC 150T CUSTOMER CALIBRATION PROCEDURE

October 1998

**NOTE:** Calibration should be attempted only on Controllers on which calibration errors have been encountered (see CALIBRATION CHECK).

## CALIBRATING THE UNIVERSAL INPUT

### Equipment Required

1. Input source with an accuracy better than  $\pm 0.05\%$  of reading:
  - (a) Thermocouple inputs - complete with  $0^{\circ}\text{C}$  reference facility, appropriate thermocouple functions and compensating leads (or equivalent).
  - (b) DC linear inputs - 0 - 5V and 0 - 20mA.
  - (c) RTD inputs - decade resistance box with connections for three-wire input (or equivalent)
2. Appropriate case assembly (DCP 100, UDC 100x or UDC 150x) wired for appropriate input supply (90 - 264V AC 50/60Hz, 20 - 50V AC 50/60Hz or 22 - 65V DC).

### Calibration Procedure

1. Ensure that the Controller is powered-off and that the mains (line) lead is disconnected. On the CPU PCB, fit the appropriate link jumpers (see Table 1 and Figure 1, Figure 2 or Figure 3 as appropriate to the type of Controller). Connect the appropriate input lead (see Figure 4 or Figure 5).
2. Connect the mains (line) lead to the Controller. Power-up the Controller and leave switched on for five minutes (for RTD and DC Linear Inputs) or 30 minutes (for thermocouple inputs), then power-down.
3. Put the Controller in Calibration Mode by powering-up the Controller and, within 30 seconds of power-up, holding down the Lower and SET UP keys simultaneously for approximately five seconds. The upper display will then show Input Type Number, in the form:



The upper display shows the text "IP\_1" in a digital font.

and the lower display will show:



The lower display shows the text "CAL" in a digital font.

Using the Raise/Lower keys, change the input type number as required (see Table 1).

**NOTE:** If required, only one input type may be calibrated. Exception: If it is required to calibrate the thermocouple input (Input Type 5), it is necessary first to calibrate the DC 0 - 50mV input (Input Type 1).

4. Press the Auto/Manual key to change the upper display to show:



The upper display shows four horizontal dashes "----".

After a few seconds, the upper display will either (a) return to the initial Input Type Number display if calibration was successful, or (b) display:



The upper display shows the text "FAIL" in a digital font.

In the latter case, the link jumpers and wiring should be checked.

**Table 1 Universal Input Type Selection**

Input Type No.	Input Type	Calibration Input	Link Jumper Settings		
			LJ1	LJ2	LJ3
1	DC - 0 - 50mV	50mV DC	Parked	Parked	Parked
2	DC 0 - 10V	10V DC	Fitted	Parked	Parked
3	DC 0 - 20mA	20mA DC	Parked	Fitted	Parked
4	RTD Three-wire	200Ω	Parked	Parked	Parked
5	Thermocouple	0°C "K"	Parked	Parked	Fitted

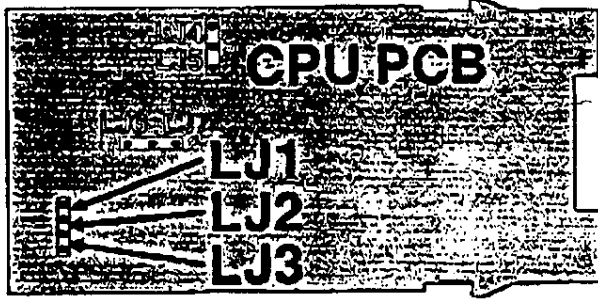

Figure 1 UDC 100x Link Jumpers (Relay/SSR Output 1)

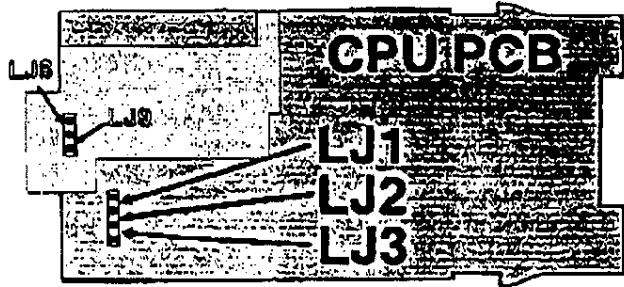

Figure 2 UDC 100x Link Jumpers (DC Output 1)

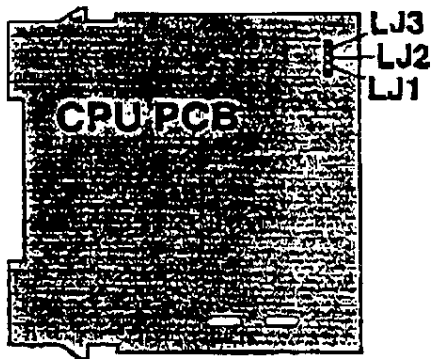

Figure 3 DCP 100/UDC 150x Link Jumpers

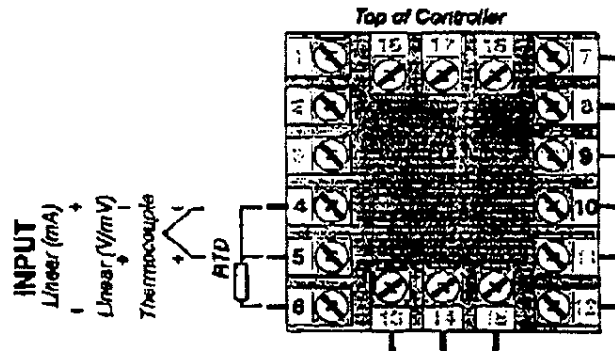

Figure 4 UDC 100x Universal Input Connections

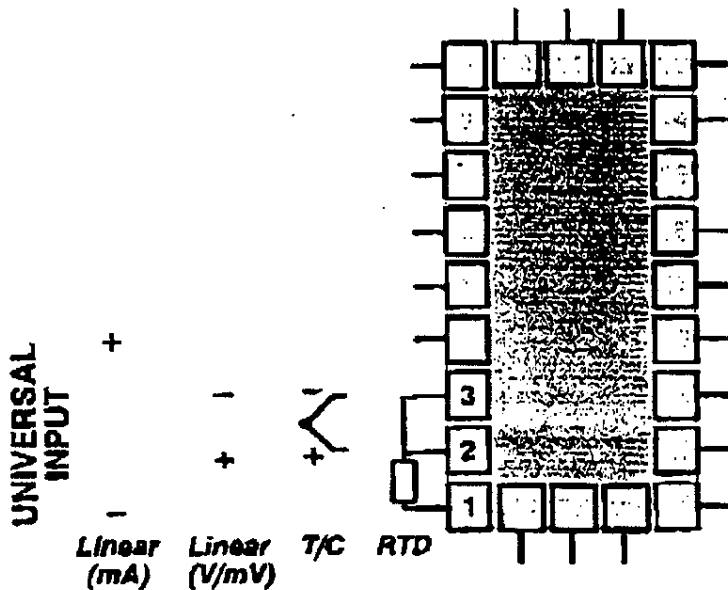

Figure 5 DCP 100/UDC 150x Universal Input Connections

Honeywell DCP 100/UDC 1000/UDC 100T/UDC 1000/UDC 100T  
Customer Calibration Procedure

5. To calibrate all inputs, repeat Steps 1 to 4 for each of the other input types (see Table 1) until all five input types have been successfully calibrated.

**NOTE:** Input Type 5 should be calibrated using the appropriate Type K compensating lead (between Terminals 2 & 3 on DCP 100/UDC 150x. Terminals 4 & 5 on UDC 100x). The Controller should be powered-up and remain powered up for at least 30 minutes with this lead connected before the input is calibrated.

The universal input calibration procedure is now complete.

### **EXIT FROM CALIBRATION MODE**

To exit from Calibration Mode, press the Lower and SET UP keys simultaneously.

**NOTE:** An automatic exit is made from Calibration Mode if there is no key activity for two minutes.

### **CALIBRATION CHECK**

1. Set the Controller to the required configuration (using link jumpers and front panel entry) as described in the appropriate Site Manual.
3. Power-up the Controller and leave it powered-up for at least five minutes (for RTD and DC linear inputs) or at least 30 minutes (for thermocouple inputs).
2. After the appropriate delay for stabilisation has elapsed, check the calibration by connecting the appropriate input source and checking a number of cardinal points.