

UDC2300 Universal Digital Controller Specification

Overview

The UDC 2300 Universal Digital Controller is a new low priced addition to Honeywell's LeaderLine family.

This controller introduces new features in the popular low priced ¼ DIN size while retaining all the reliability, cost effectiveness, simplicity, and popular HMI of Honeywell's UDC 2000.

The UDC 2300 monitors and controls temperatures and other variables in applications such as environmental chambers, plastic processing machines, furnaces and ovens, and packaging machinery. The standard features include AccutuneII™ and the popular single display, automatic mode model. A Dual Display model with Automatic/Manual control modes is optional. A Limit Control model is also available.

The UDC 2300 provides a low priced, 1/4 DIN sized alternative for many applications. Its new features include:

- Universal AC power supply,
- RS485 ASCII or Modbus® RTU communications option,
- Input/Output isolation, and
- Isolated Auxiliary Current output.

These features when combined with the new AccutuneII™ tuning with Fuzzy Logic overshoot suppression, result in price/performance leadership in the performance segment positioned below the UDC 3300 Controller.

For the many thousands of satisfied UDC 2000 users, UDC 2300 is downward compatible with existing UDC 2000 applications and installations. It even uses the same case; therefore, it can be easily inserted into existing panel installations.

©Modbus is a trademark of AEG Modicon

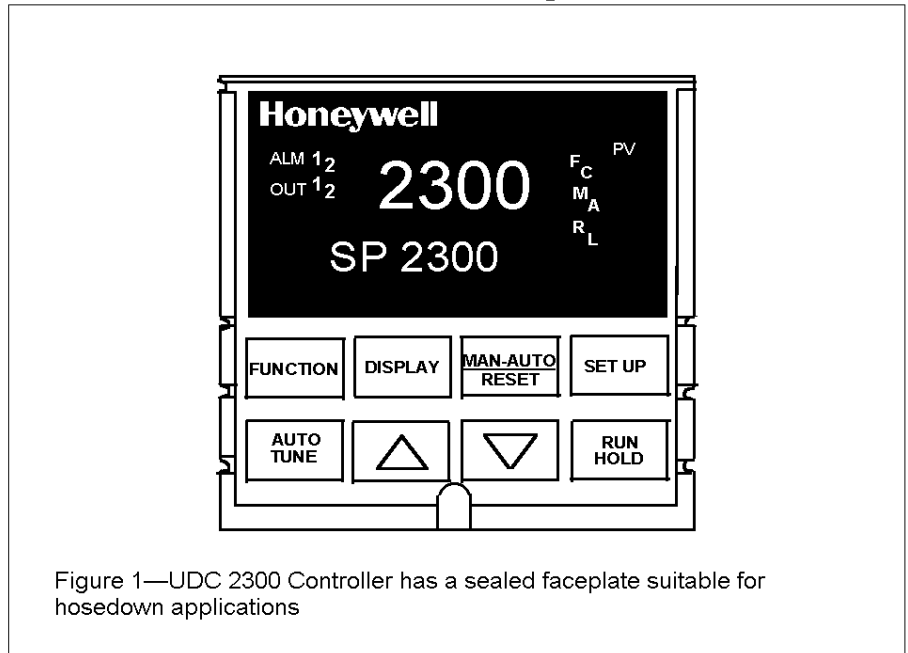

Figure 1—UDC 2300 Controller has a sealed faceplate suitable for hosesdown applications

Features/Options

High Accuracy—Typically $\pm 0.25\%$ of full scale input with a typical resolution of 15 bits.

Analog Inputs—Two inputs are available. The first input accepts all thermocouple, RTD, mA, mV, and voltage types (See Table 1.). Alternatively, the second input is a high level input and can be used as a remote setpoint, for data acquisition, a parameter to be alarmed on, or as a slidewire input for Position Proportional control applications. All input types are configurable. All inputs are sampled six times per second (every 166 ms). These two inputs are isolated from all other inputs and outputs, but not from each other.

Dual Setpoints - Simple push-button selection allows quick switchover from primary to alternate setpoint with minimal operator confusion.

Manual/Automatic Modes—Bumpless, balanceless transfer between control modes. Available with a Dual Display option and SP Programming option.

Features/Options, continued

Accutune II™—This standard feature provides a new, truly plug and play tuning algorithm, which will, at the touch of a button or through a digital input, accurately identify and tune any process including those with deadtime and integrating processes. This speeds up and simplifies start-up plus allows retuning at any setpoint.

Fuzzy Logic—This standard feature uses fuzzy logic to suppress process variable overshoot due to SP changes or externally induced process disturbances. It operates independently from AccutuneII™ tuning. It does not change the PID constants, but temporarily modifies the internal controller response to suppress overshoot. This allows more aggressive tuning to co-exist with smooth PV response. It can be enabled or disabled depending on the application or the control criteria.

CE Mark—Conformity with 73/23/EEC, Low Voltage Directive and 89/336/EEC, the EMC Directive as a standard feature.

Features/Options, continued

Auxiliary Output* (Optional)—This isolated Auxiliary Output can be scaled from 4-20 mA for 0 to 100% for any range. It can be configured to represent Input 1, Input 2, PV, active Setpoint, Local SP1, Deviation, or the Control Output.

Communications* (Optional)—Provides a communications link between the UDC 2300 and host computer or PLC via the RS422/485 ASCII or Modbus® RTU communications option.

Digital Input* (Optional)—Provides isolated digital input for remote dry contact closure to select one of the following actions:

- Manual control mode
- Local setpoint 1
- Local setpoint 2
- Direct controller action
- Hold SP Ramp/Programming
- Select PID set 2
- To Run - SP Ramp/Program
- External program reset
- Disable PID integral action
- Manual mode, failsafe output
- Disable keyboard
- Start Timer
- Initiate Tuning
- Initiate PV Hot Start
- Output tracks Input 2
- To Remote Setpoint
- To Latching Manual Mode

Also the digital input can allow one of the following selections to be combined with one of the above selections:

- Select PID set 2
- Direct controller action
- Local setpoint 2
- Local setpoint 1
- To Run

New Alarm Function Features

- Alarms can be configured as latching or non-latching.
- Alarm blocking is also available which allows start-up without alarm energized until after it first reaches the operating region.
- PV rate of change alarm
- Loop break alarm
- Timer output reset

Universal Switching Power —

Operates on any line voltage from 90 to 264 Vac 50/60 Hz without jumpers. 24 Vac/dc instrument power is available as an option.

Features/Options, continued

Moisture Protection —IP65/NEMA 3 rated front face permits use in applications where it may be subjected to moisture, dust, or hose-down conditions.

Limit Control—Provides a latching relay, which is activated whenever the PV goes above or below a preset setpoint value. An alarm indicator will light when the output is activated. Reset is through a key on the front of the controller or an external switch. A FM approved model is available.

Approval Body Options—FM approval and CSA certification are available options. A UL listing applies to regulatory use only and is a standard feature.

Timer—This standard feature provides a configurable time period of 0 to 99 hours, 59 minutes or units of minutes and seconds. It can be started via the keyboard, alarm 2, or by a digital input. The timer output is Alarm 1 which energizes at the end of the Timer Period. Alarm 1 can be automatically reset. The Timer Period can be changed between each batch. Status is shown on the lower display.

Heat/Cool Capability—Provides split range control with independent PID tuning constants—one for heating, one for cooling—plus mixed output forms.

Setpoint Ramp/Soak Programming (Optional)—Enables you to program and store six Ramp and six Soak segments for setpoint programming. Run or Hold of program is keyboard or remote digital switch selectable.

Setpoint Rate—Lets you define a ramp rate to be applied to any local setpoint change. A separate upscale or downscale rate is configurable. A single setpoint ramp is also available as an alternative.

Thermocouple Failsafe—Configurable upscale or downscale burnout and failsafe output level.

Decimal Point Location—Configurable for none, one, or two places.

Indicator Model—A single display indicator model is available. Optional features include: 2 alarms plus Auxiliary Output or Communications.

Features/Options, continued

Dedicated Keys—Provide direct access setpoint modes and setpoint program status to simplify and speed operation.

Two Sets of Tuning Constants—Two sets of PID parameters can be configured for each loop and automatically or keyboard selected.

Alarm Selection—None, one, or two relays to activate external equipment when preset high/low setpoints are reached. There is an indicator for each alarm. For Duplex or 3 Position Step operation, only one alarm is available.

Data Security—Five levels of keyboard security protect tuning, configuration, and calibration data, accessed by a configurable 4-digit code. Nonvolatile EEPROM memory assures data integrity during loss of power.

Diagnostic/Failsafe Outputs - Continuous diagnostic routines detect failure modes, trigger a failsafe output value and identify the failure to minimize troubleshooting time.

High Noise Immunity - The controller is designed to provide reliable, error-free performance in industrial environments that often affect highly noise-sensitive digital equipment.

Quality/Support—The UDC 2300 is covered by a 2-year warranty and backed up by a toll-free phone number for technical assistance.

Transmitter Power—Provides up to 30 volts dc to power a 2-wire transmitter. (Requires use of alarm 2 open collector output selection or auxiliary output.)

Physical Description

The controller is housed in a 4.2-inch deep, black metal case with a dark gray elastomer bezel, that can be panel mounted in a 1/4 DIN cutout. (See Figure 5.) The plug-in chassis allows easy access to the controller board and its various option boards. All power, input, and output wiring are connected to screw terminals on the rear panel. (See Figure 6.) Blue and tan elastomer bezels are optionally available.

*Auxiliary Output, Digital Input, and Communications are mutually exclusive.

Configuration

You decide how the controller is to interact with the process by selecting, through simple keystrokes, the functions you want.

Multi-language prompts guide the operator step-by-step through the configuration process assuring quick and accurate entry of all configurable parameters. Five languages are available via configuration: English, French, German, Spanish and Italian.

Inputs

The analog inputs are sampled six times a second.

The UDC 2300 is available with one or two inputs. The first input, or Process Variable input, can be one of the various thermocouple, RTD, Radiamatic or linear actuators. Linear actuators have thermocouple, RTD, and Radiamatic transmitter characterization capability as a standard feature.

The optional second input is a high level input and accepts ranges of 0-5V, 1-5V, 0-20mA, or 4-20mA.

All actuators and characterizations are keyboard configurable. Cold junction compensation is provided for thermocouple type inputs. Upscale or downscale sensor break protection is keyboard configurable. A configurable digital filter of 0 to 120 seconds provides input signal damping.

Output Types

The following output types are available per the model selection guide:

- Current Output
- Electromechanical Relays (5 amps)
- Solid State Relays (1 amp)
- Solid State Relays (10 amps) externally mounted (optional)
- Open Collector Outputs
- Auxiliary Current Output (optional)

Output Algorithms

The UDC 2300 is available with one or more of the following output algorithms:

Time Proportional—Provides On-Off or Time Proportional (Relay) output.

Current Proportional—Supplies proportional direct current output for final control elements which require a 4-20 mA signal.

Current Proportional Duplex—Similar to current proportional but provides a second set of tuning parameters and a split range current output or a second current output via the Auxiliary output option, for the heat and cool zones.

Time Proportional Duplex—Depending on which control algorithm you select, this duplex output algorithm can provide On-Off Duplex, Time Proportional Duplex, or Three Position Step Control. The time proportional duplex output provides independent PID tuning constants and two time proportional outputs; one for heat zone above the 50% output, and one for cool zone below 50% output.

Current/Relay Duplex (Relay = Heat)—A variation of Duplex with Current active for 0 to 50% output (PID Set 2) and Relay 2 active 50 to 100% output (PID Set 1). Note that only one alarm is available.

Relay/Current Duplex (Relay = Cool)—A variation of Duplex with Current active for 50 to 100% output and Relay 2 is active for 0 to 50% output. Note that only one alarm is available.

Universal Output Model—Flexibility of the output algorithms allows the current output with two alarms model (DC230B-CE) to also be configured for current simplex, current duplex, and time simplex. A relay output model with auxiliary output option (DC230B-CE-2) can also be configured for these output algorithms. Note that only current simplex and current duplex can have 2 alarms.

Control Algorithms

Depending on the output algorithms specified, the controller can be configured for the following control algorithms:

- **On-Off**
- **PID-A**
- **PID-B**
- **PD with Manual Reset**
- **Three Position Step Control**

The Three Position Step Control algorithm allows the control of a valve (or other actuator), with an electric motor driven by two controller output relays; one to move the motor upscale, the other downscale without a feedback slidewire linked to the motor shaft.

Control Modes

The controller is capable of operating in three different control modes:

1. Manual
 2. Automatic with Local Setpoint
 3. Automatic with Remote Setpoint
- The manual and automatic control modes with local and remote setpoint, and bumpless, balanceless transfer between modes.

Alarms

Alarm output terminals are located at the rear terminal panel. One or two electromechanical alarm relays are available to activate external equipment when preset alarm setpoints are reached. Each of the two alarms can be set to monitor two independent setpoints. Each alarm setpoint can be either high or low alarm. The alarm type can be selected to be either of the inputs, the Process Variable, Deviation, Output, Shed from communications, PV rate of change, or to alarm on manual mode. It can also be used as an On or Off event at the beginning or end of a Ramp/Soak segment. The alarm hysteresis is configurable from 0 to 100% of range.

Configurable alarm features include:

- Alarm latching or non-latching
- Alarm blocking
- PV rate of change alarm
- Loop break alarm (Future)
- Timer reset

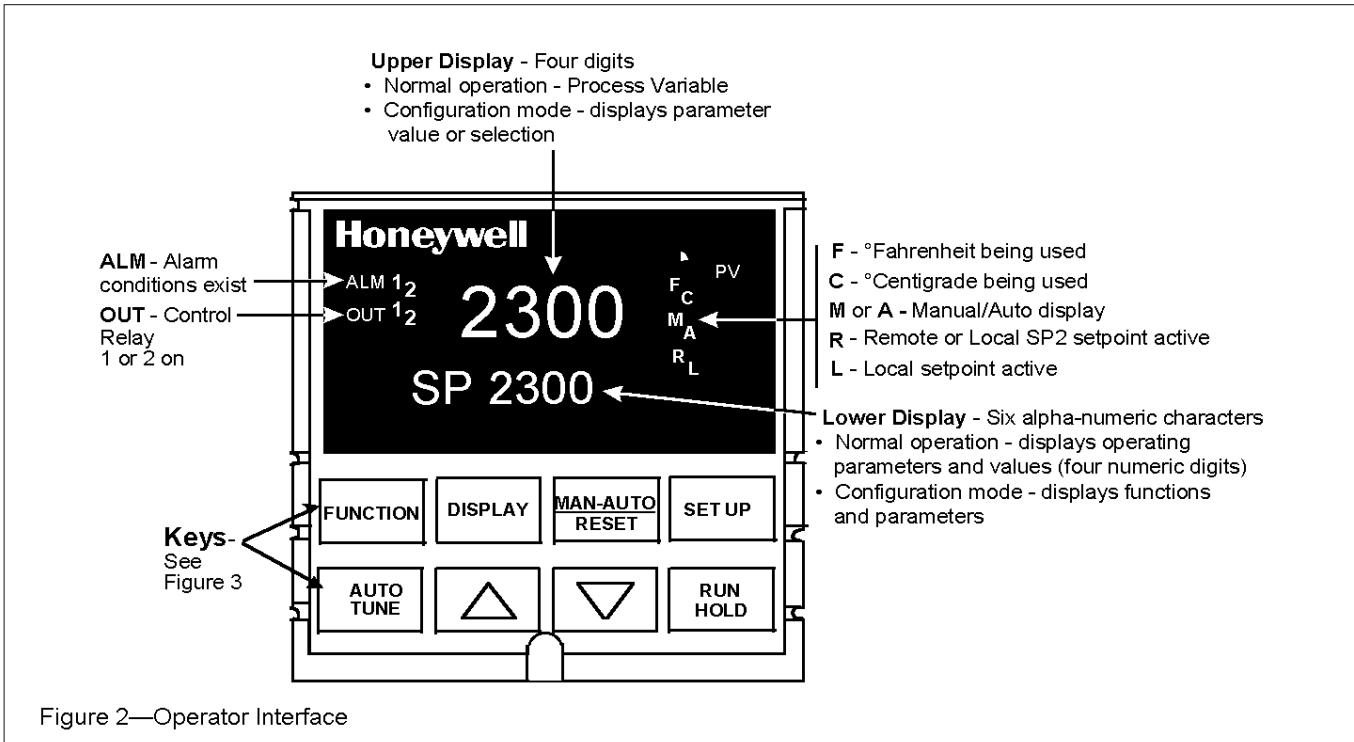

Figure 2—Operator Interface

Operator Interface (Figure 2)

Indicators—Provide alarm, control mode, and temperature unit indication. There is also indication of when Remote Setpoint is active, the status of the control relays, and whether a setpoint program is in Run or Hold mode.

Displays—A 4-digit upper display is dedicated to the process variable during normal operation with alternate information displayed when in the configure mode. The upper display is also dedicated to the single display model operation and also shows Setpoint output or Deviation on demand. The *Indicator* model uses the Upper Display only.

During normal operation of the dual display model, the six character alpha-numeric lower display shows key-selected operating parameters such as Output, Setpoints, Inputs, Deviation, active Tuning Parameter Set, Timer Status, or minutes remaining in a setpoint ramp. It also provides guidance, through language prompts, for the operator during controller configuration.

Eight keys enable complete configuration and operation

FUNCTION	Selects functions within each configuration group. Selects 2nd Setpoint or Remote Setpoint.
DISPLAY	Returns Controller to normal display from Set Up mode. Toggles various operating parameters for display.
MAN-AUTO RESET	Selects Manual or Auto mode. Resets the latching Limit Controller relay. In Set Up mode, used to restore original value or selection.
SET UP	Scrolls through the configuration groups.
AUTO TUNE	Initiates Limit Cycle Tuning.
▲	Increases setpoint or output value. Increases the configuration values or changes functions in Configuration mode groups.
▼	Decreases setpoint or output value. Decreases the configuration values or changes functions in Configuration mode groups.
RUN HOLD	Enables Run/Hold of the SP Ramp or Program plus Timer start.

22350.ppt

Figure 3—Key Functions

Specifications

Design	
<p>CE Conformity (Europe)</p> <p>Product Classification:</p> <p>Enclosure Rating:</p> <p>Installation Category (Overvoltage Category):</p> <p>Pollution Degree:</p> <p>EMC Classification:</p> <p>Method of EMC Assessment:</p> <p>Declaration of Conformity:</p>	<p>This product is in conformity with the protection requirements of the following European Council Directives: 73/23/EEC, the Low Voltage Directive, and 89/336/EEC, the EMC Directive. Conformity of this product with any other "CE Mark" Directive(s) shall not be assumed.</p> <p>Class I: Permanently Connected, Panel Mounted Industrial Control Equipment with protective earthing (grounding). (EN61010-1)</p> <p>Panel Mounted Equipment, IP 00, this controller must be panel mounted. Terminals must be enclosed within the panel. Front panel IP 65 (IEC 529).</p> <p>Category II: Energy-consuming equipment supplied from the fixed installation. Local level appliances, and Industrial Control Equipment. (EN 61010-1)</p> <p>Pollution Degree 2: Normally non-conductive pollution with occasional conductivity caused by condensation. (Ref. IEC 664-1)</p> <p>Group 1, Class A, ISM Equipment (EN 55011, emissions), Industrial Equipment (EN 50082-2, immunity)</p> <p>Technical File (TF)</p> <p>51309871-000</p>
Input Accuracy	<p>± 0.25% of full scale typical (±1 digit for display)</p> <p>Can be field calibrated to ±0.05% of full scale typical</p> <p>15-bit resolution typical</p>
Sampling Rate	Inputs sampled six times a second
Temperature Stability	±0.025% of full scale span per °C typical
Input Signal Failure Protection	<p><i>Thermocouple Inputs:</i> Upscale or downscale burnout</p> <p><i>Burnout Current:</i> 0.13 microamps</p> <p><i>Failsafe Output Level:</i> Configurable 0-100%</p>
Input Impedance	<p><i>4-20 Milliampere Input:</i> 249 ohms</p> <p><i>0-10 Volt Input:</i> 200K ohms</p> <p><i>All Other:</i> 10 megohms</p>
Maximum Lead Wire Resistance	<p><i>Thermocouples:</i> 100 ohms/leg</p> <p><i>100, 200, and 500 RTD:</i> 100 ohms/leg</p> <p><i>100 Low RTD:</i> 10 ohms/leg</p>
Stray Rejection	<p>Common Mode</p> <p><i>AC (50 or 60 Hz):</i> 120 dB (with maximum source impedance of 100 ohms) or ±1 LSB (least significant bit) whichever is greater with line voltage applied.</p> <p><i>DC:</i> 120 dB (with maximum source impedance of 100 ohms) or a ±1 LSB whichever is greater with 120 Vdc applied.</p> <p><i>DC (to 1 KHz):</i> 80 dB (with maximum source of impedance of 100 ohms) or ±1 LSB whichever is greater with 50 Vac applied.</p> <p>Normal Mode</p> <p><i>AC (50 or 60 Hz):</i> 60 dB (with 100% span peak-to-peak maximum)</p>
Alarm Outputs	<p>One SPDT electromechanical relay.</p> <p>A second alarm is available using the second control relay. This is not available with Relay Duplex, Time/Current Duplex, or Three-Position Step control.</p> <p>Up to four setpoints are independently set as high or low alarm, two for each relay. Setpoint can be on any Input, Process Variable, Deviation, Manual Mode, Failsafe, PV Rate, RSP Mode, Communication Shed, or Output. A single adjustable hysteresis of 0.0 to 100.0% is provided. The alarm can also be set as an ON or OFF event at the beginning of a setpoint ramp/soak segment.</p> <p><i>Alarm Relay Contacts Rating</i></p> <p><i>Resistive Load:</i> 5 ampere at 120 Vac or 30Vdc, 2.5 ampere at 240Vac</p>
Controller Output Types	<p>Current Output</p> <p>Range can be set anywhere between 0 to 21 mA, and as direct or reverse action.</p> <p><i>Resolution:</i> 11 bits for 0 to 21 mA</p> <p><i>Accuracy:</i> 0.5% full scale</p> <p><i>Temperature Stability:</i> 0.1% F.S./°C</p> <p><i>Load Resistance:</i> 0 to 750 ohms</p>

Specifications, continued

Design (continued)	
Controller Output Types (continued)	<p>Electromechanical Relays (One or Two) SPDT contacts. Both Normally Open and Normally Closed contacts are brought out to the rear terminals. Internally socketed <i>Resistive Load:</i> 5 amps @ 120 Vac or 30Vdc, 2.5 ampere at 240Vac <i>Inductive Load:</i> 50 VA @ 120 Vac or 240 Vac <i>Motor:</i> 1/6 H.P.</p> <p>Solid State Relays (One or Two) SPST solid state contacts consisting of a triac N.O. output. Internally socketed <i>Resistive Load:</i> 1.0 amp @ 25°C and 120 or 240 Vac 0.5 amp @ 55°C and 120 or 240 Vac <i>Inductive Load:</i> 50 VA @ 120 Vac or 240 Vac <i>Minimum Load:</i> 20 milliamps</p> <p>Open Collector Outputs (One or Two) <i>Maximum Sink Current:</i> 20 mA <i>Overload Protection:</i> 100 mA Internally powered @ 25 Vdc Opto-isolated from all other circuits except current output, but not from each other. Socketed jumper assembly replaces relay.</p> <p>Solid State Relays (10 amps) One or two externally mounted SPST triac N.O. outputs for use with open collector outputs. <i>Resistive Load:</i> 15 amps @ 25°C and 120 or 240 Vac 10 amps @ 55°C and 120 or 240 Vac <i>Inductive Load:</i> 50 VA @ 120 Vac or 240 Vac <i>Motor Rating:</i> 1 HP @ 25°C 0.75 HP @ 55°C</p>
Controller Output Algorithms	<p>On-Off or Time Proportional One relay or open collector output. Control action can be set for direct or reverse. <i>Time Proportional Relay Resolution:</i> 3.3 msec</p> <p>On-Off Duplex, Three Position Step Control, or Time Proportional Duplex Two relays or open collector outputs. Control action can be set for direct or reverse. <i>Time Proportional Relay Duplex Resolution:</i> 3.3 msec</p> <p>Current Proportional A single 4-20 mA current output signal which can be configured for direct or reverse action.</p> <p>Current Proportional Duplex A single split current output for both heat and cool (4-12 cool, 12-20 heat) or a combination of current proportional output (Heat = 50 to 100% of range) and auxiliary current output (Cool = 0 to 50% of range). Both are 4-20 mA signals which can be set for direct or reverse action.</p> <p>Current/Time Duplex Variation of time proportional duplex for Heat/Cool applications. Time proportional output (heat or cool) is a relay. Current proportional output (Heat or Cool) is a 4-20 mA signal that can be fed into a negative or positive grounded load of 0 to 750 ohms and is operational over 50% of range or the entire range.</p>
Digital Input (Optional) (Isolated)	+25 Vdc source for external dry contacts or isolated solid state contacts. The Digital Input option detects the state of external contact. On contact closure the controller will respond according to how the digital input is configured. Opening contact causes return to previous state.
Input Filter	<i>Software:</i> Single pole lowpass section with selectable time constants, off to 120 seconds available on both analog inputs.

Specifications, continued

Design (continued)	
Auxiliary Linear Output (Optional) (Isolated)	<p>21 mA dc maximum into a negative or positive grounded load or non-grounded load of 0 to 500 ohms. Output range can be set anywhere between 0 to 21 mA, and as direct or reverse action. It can be configured to represent IN1, IN2, PV, Setpoint, LSP1, Deviation, or Control output. The range of the auxiliary output, as a function of the selected variable, can be scaled. This output can be used as a second current output for current duplex outputs.</p> <p><i>Resolution:</i> 12 bits over 0 to 21 mA <i>Accuracy:</i> 0.1% of full scale <i>Temperature Stability:</i> 0.01% F.S./°C <i>Load Resistance:</i> 0 to 500</p>
Communications Interface (Optional)	
RS422/485 ASCII	<p><i>Baud Rate:</i> 2400, 4800, 9600, or 19200 baud <i>Parity:</i> Odd or Even <i>Length of Link:</i> 2000 ft. maximum <i>Link Characteristics:</i> Two-wire (half duplex), multi-drop RS422 ASCII, 31 drops maximum.</p>
RS422/485 Modbus RTU	<p><i>Baud Rate:</i> 2400, 4800, 9600, or 19200 baud selectable <i>Data Format:</i> Floating point or integer <i>Length of Link:</i> 2000 ft. maximum <i>Link Characteristics:</i> Two-wire (half duplex), multi-drop Modbus RTU protocol, 31 drops maximum.</p>
Setpoint Ramp/Soak Programming (Optional)	Lets you configure 6 ramp and 6 soak segments to be stored for use as one program or several small programs. You designate the beginning and end segments to determine where the program is to start/stop allowing several small programs. Each ramp segment can be configured to be run in Hours and Minutes or degrees per minute. Soak segments can have a guaranteed soak deviation which guarantees the time for each soak and will not start until the PV is reached.
Digital Displays	<p>Vacuum fluorescent, Dual Displays A four-character upper display dedicated to the process variable. Alternate information displayed during configuration mode. A six-character, alphanumeric lower display primarily shows key selected operating parameters. Also provides guidance during controller configuration.</p>
Indicators	<p>Alarm Relay Status (ALM 1 or 2) Control Mode (A or M) Temperature Units (F or C) Remote Set Point or SP2 Active (R) Control Relay Status (OUT 1 or 2)</p>
Modes of Operation	<p>Manual (Available on Dual Display version only.) Automatic with local setpoint Automatic with remote setpoint</p>
Dimensions	See Figure 5.
Mounting	Panel-mounted, 4.2-inch depth
Wiring Connections	Screw terminals on the rear of the case. (See Figure 6.)
Power Consumption	12 VA maximum (90 to 264 Vac) and (24 Vac/dc)
Power Inrush Current	<p>10A maximum for 4 ms (under operating conditions)</p> <p>CAUTION When applying power to more than one UDC 2300, make sure that sufficient power is supplied. Otherwise, the controllers may not start up normally due to voltage drop from the inrush current.</p>
Weight	1 kg (2.2 lbs.)

Specifications, continued

Environmental and Operating Conditions				
Parameter	Reference	Rated	Operative Limits	Transportation and Storage
Ambient Temperature	25 ± 3°C 77 ± 5°F	0 to 55°C 32 to 131°F	0 to 60°C 32 to 140°F	-40 to 66°C -40 to 151°F
Relative Humidity	10 to 55*	10 to 90*	5 to 90*	5 to 95*
Vibration Frequency (Hz) Acceleration (g)	0 0	0 to 70 0.4	0 to 200 0.6	0 to 200 0.5
Mechanical Shock Acceleration (g) Duration (ms)	0 0	1 30	5 30	20 30
Voltage (Vdc, Vac)	+24 ±1	20 to 27	20 to 27	--
Voltage (Vac) 90 to 264 Vac (CSA models rated to 250V max.)	120 ±1 240 ±2	90 to 264	90 to 264	-- --
Frequency (Hz) (For Vac)	50 ±0.2 60 ±0.2	49 to 51 59 to 61	48 to 52 58 to 62	-- --

* The maximum rating only applies up to 40°C (104°F). For higher temperatures, the RH specification is derated to maintain constant moisture content.

Table 1—Input Actuators

PV Input	Range	
	°F	°C
Thermocouples (Per ITS-90)		
B	0 to 3300	-18 to 1816
E	-454 to 1832	-270 to 1000
E (low)	-200 to 1100	-129 to 593
J	0 to 1600	-18 to 871
J (low)	20 to 770	-7 to 410
K	0 to 2400	-18 to 1316
K (low)	-20 to 1000	-29 to 538
NiNiMoly (NNM68)	32 to 2500	0 to 1371
NiNiMoly (low)	32 to 1260	0 to 682
NiMo-	32 to 2500	0 to 1371
NiCo(NNM90)	32 to 1260	0 to 682
NiMo-NiCo (low)	0 to 2372	-18 to 1300
Nicrosil Nisil (NIC)	0 to 3100	-18 to 1704
R	0 to 3100	-18 to 1704
S	-300 to 700	-184 to 371
T	-200 to 500	-129 to 260
T (low)	0 to 4200	-18 to 2315
W5W26	0 to 2240	-18 to 1227
W5W26 (low)		
Honeywell Radlamic		
Type RH	0 to 3400	-18 to 1871
Type RI	0 to 9999 max.*	-18 to 9999 max.*

*User enters the range manually per RI type and application.

PV Input	Range	
	°F	°C
RTD IEC Alpha = 0.00385		
100 ohms	-300 to 1200	-184 to 649
100 ohms (low)	-300 to 300	-184 to 149
200 ohms	-300 to 1200	-184 to 649
500 ohms	-300 to 1200	-184 to 649
Linear		
Milliamps	4 to 20 mA 0 to 20 mA	
Millivolts	0 to 10 mV 0 to 100 mV	
Volts	1 to 5 V 0 to 5 V 0 to 10V	

Dimensions

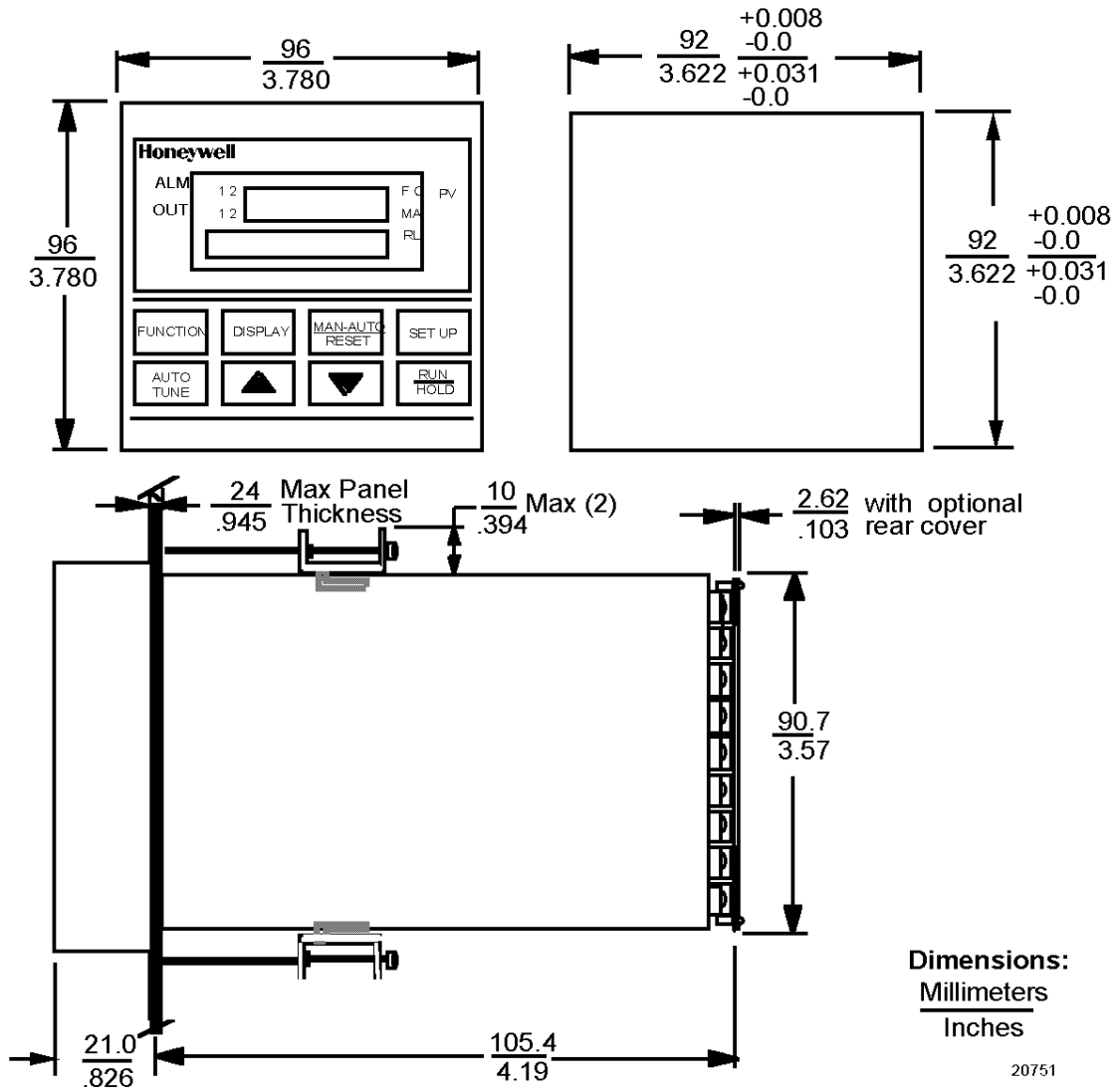

Dimensions:
Millimeters
Inches

20751

Figure 5—UDC 2300 Controller Dimensions – not to scale

Wiring Diagram

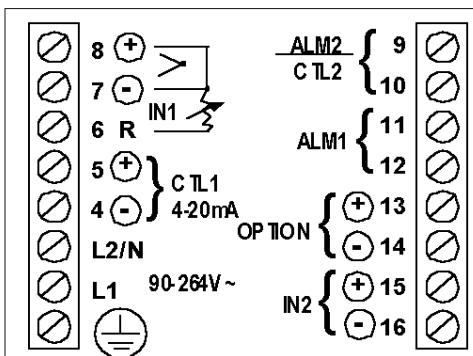

24865

Figure 6—External Wiring Diagram

Ordering Information

For the complete ordering information, request Model Selection Guide 51-51-16-59 for UDC 2300 Universal Digital Controller.

Honeywell offers a full line of Sensors, Transmitters, and Final Control Devices for use with the UDC 2300 Universal Digital Controller. These devices include:

- Thermocouples,
- RTDs,
- Pressure Transmitters,
- Flow Transmitters,
- Liquid Level Transmitters,
- Valves,
- Actuators, and
- Electric Motors.

Specifications are subject to change without notice.

Distributor :

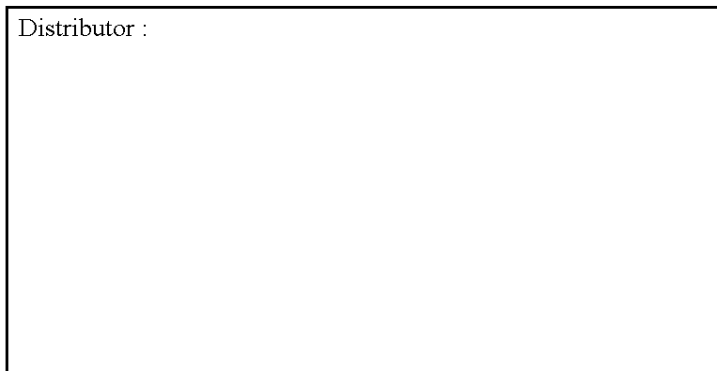

For more information, contact your nearest Honeywell Response Center listed below.

Honeywell

Industrial Automation and Control

Helping You Control Your World

Honeywell Inc.

In the U.S.A.: Honeywell Industrial Automation and Control, 16404 North Black Canyon Hwy., Phoenix, AZ 85023, (800) 343-0228

In Europe: Honeywell S.A., 80084 Amiens Cedex 2, (33) 22.54.56.56

Honeywell Control System Ltd., Honeywell House, Bracknell, UK-RG 12 1 EB, (44) 1344 826000

In Japan: Yamatake-Honeywell Co. Ltd., Nagai Int'l Bldg., 2 - 12 - 19 Shibuya-Ku, Tokyo 150 Japan, 81-3-3486-2051

In Asia: Honeywell Asia Pacific Inc., Room 3213-3225, Sun Hung kai Centre, No. 30 Harbor Road, Wanchai, Hong Kong, (852) 829-8298

In the Mediterranean: Africa and Middle East Region, Honeywell SpA, Via Vittor Pisani 13, 20124 Milano, Italy (39-2) 67731

Honeywell Pacific Division: Honeywell Pty Ltd., 5 Thomas Holt Drive, North Ryde Sydney, NSW Australia 2113, (61-2) 353 7000

In Canada: The Honeywell Centre, 155 Gordon Baker Road, Ontario M2H 3N7, 1-800-461-0013

In Latin America: Honeywell Inc., 14505 Commerce Way, Suite 500, Miami Lakes, Florida 33016-1556, (305) 364-2300
