

2.5 Wiring

Electrical Considerations



The controller is considered “rack and panel mounted equipment” per EN61010-1, Safety Requirements for Electrical Equipment for Measurement, Control, and Laboratory Use, Part 1: General Requirements. Conformity with 72/23/EEC, the Low Voltage Directive requires the user to provide adequate protection against a shock hazard. The user shall install this controller in an enclosure that limits OPERATOR access to the rear terminals.

Mains Power Supply

This equipment is suitable for connection to 90 to 264 Vac, 50/60 Hz, power supply mains. It is the user’s responsibility to provide a switch and non-time delay (North America), quick-acting, high breaking capacity, Type F (Europe), 1/2A, 250V fuse(s), or circuit-breaker, as part of the installation. The switch or circuit breaker shall be located in close proximity to the controller, within easy reach of the OPERATOR. The switch or circuit breaker shall be marked as the disconnecting device for the controller.

Controller Grounding

PROTECTIVE BONDING (grounding) of this controller and the enclosure in which it is installed shall be in accordance with National and Local electrical codes. To minimize electrical noise and transients that may adversely affect the system, supplementary bonding of the controller enclosure to a local ground, using a No. 12 (4 mm²) copper conductor, is recommended.

Control/Alarm Circuit Wiring

The insulation of wires connected to the Control/Alarm terminals shall be rated for the highest voltage involved. Extra Low Voltage (ELV) wiring (input, current output, and low voltage Control/Alarm circuits) shall be separated from HAZARDOUS LIVE (>30 Vac, 42.4 V_{peak}, or 60 V_{dc}) wiring per Permissible Wiring Bundling, Table 2-5.

Electrical Noise Precautions

Electrical noise is composed of unabated electrical signals, which produce undesirable effects in measurements and control circuits.

Digital equipment is especially sensitive to the effects of electrical noise. Your controller has built-in circuits to reduce the effect of electrical noise from various sources. If there is a need to further reduce these effects:

- *Separate External Wiring*—Separate connecting wires into bundles (See Permissible Wiring Bundling - Table 2-5) and route the individual bundles through separate conduit metal trays.

- *Use Suppression Devices*—For additional noise protection, you may want to add suppression devices at the external source. Appropriate suppression devices are commercially available.

ATTENTION

For additional noise information, refer to Document #51-52-05-01, *How to Apply Digital Instrumentation in Severe Electrical Noise Environments*.

Permissible Wiring Bundling

Table 2-5 Permissible Wiring Bundling

Bundle No.	Wire Functions
1	<ul style="list-style-type: none"> • Line power wiring • Earth ground wiring • Control relay output wiring • Line voltage alarm wiring
2	<p>Analog signal wire, such as:</p> <ul style="list-style-type: none"> • Input signal wire (thermocouple, 4 to 20 mA, etc.) • 4-20 mA output signal wiring <p>Digital input signals</p>
3	<ul style="list-style-type: none"> • Low voltage alarm relay output wiring • Low voltage wiring to solid state type control circuits

Universal Output Functionality and Restrictions

Table 2-6 Universal Output Functionality and Restrictions

Output Type	Output/Socket		Relay #			Auxiliary Output
	Current Output	Relay #1	Relay #2	Relay #3		
Time Simplex 1	N/I	Output 1	Alarm 2	Alarm 1	Not Needed	
Time Simplex 2	N/A	N/I	Output 1	Alarm 1	Not Needed	
Current Simplex	Output	N/I	Alarm 2	Alarm 1	Not Needed	
Time Duplex or TPSC	N/I	Output 1	Output 2	Alarm 1	Not Needed	
Current Dup. 100%	Output 1	N/I	Alarm 2	Alarm 1	Not Needed	
Current Dup. 50%	Output 1	N/I	Alarm 2	Alarm 1	Output 2	
Current/Time	Output 1	N/I	Output 2	Alarm 1	Not Needed	
Timer/Current	Output 2	N/I	Output 1	Alarm 1	Not Needed	

N/I = Not Installed

N/A = The output form or the individual output is Not Available or is not used for this output form.

Not Needed = Auxiliary Output is not needed to provide the desired output function and can be used for another purpose. Auxiliary Output could also be used as a substitute for current Output 1.

2.6 Wiring the Controller

Using the information contained in the model number, select the appropriate wiring diagrams from the composite wiring diagram below. Refer to the individual diagrams listed to wire the controller according to your requirements.

Composite Wiring Diagram	11
Mains Power Supply	12
Input 1 Connections	12
Input 2 Connections	12
Relay Output	
Electromechanical	13
Solid State	13
Open Collector	14
Current Output Connections	14
External Solid State Relay Output Option	15
Three Position Step Control Connections	15
Alarm and Duplex Output Connections	16
External Interface Option Connections	17
Transmitter Power for 4-20mA – 2-Wire Transmitter	18
Using Open Collector Alarm 2 Output	
Transmitter Power for 4-20mA – 2-Wire Transmitter	18
Using Auxiliary Output	

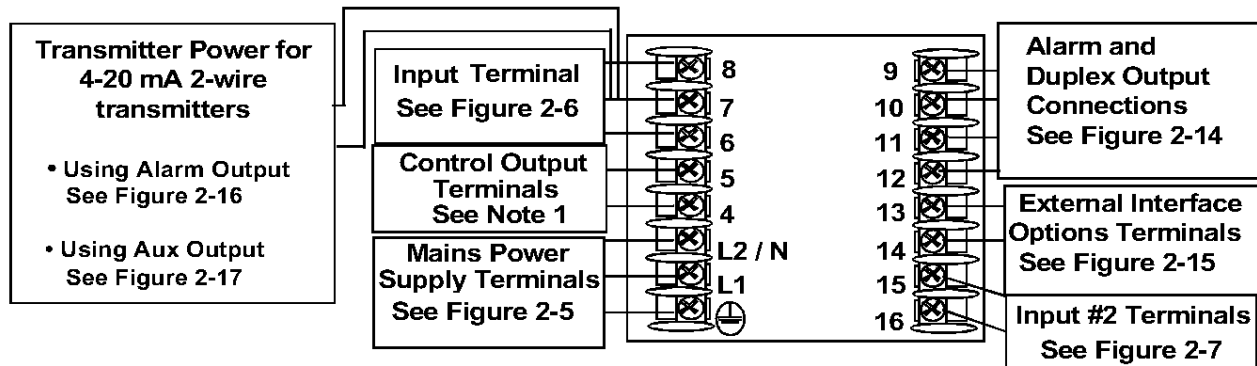

NOTE1: Time Proportional Electromechanical Relay Output – See Figure 2-8
 Time Proportional Solid State Relay Output – See Figure 2-9
 Time Proportional Open Collector Output – See Figure 2-10
 Current Output – See Figure 2-11
 External Solid State Relay Output – See Figure 2-12
 Three Position Step Control Output – See Figure 2-13

24855

Figure 2-4 Composite Wiring Diagram

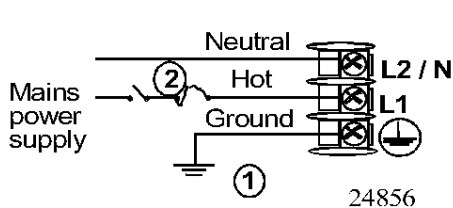

① PROTECTIVE BONDING (grounding) of this controller and the enclosure in which it is installed, shall be in accordance with National and Local electrical codes. To minimize electrical noise and transients that may adversely affect the system, supplementary bonding of the controller enclosure to a local ground, using a No. 12 (4 mm²) copper conductor, is recommended. **Before powering the controller, see “Preliminary Checks” in this section of the user manual for switch and jumper settings.**

② Provide a switch and non-time delay (North America), quick-acting, high breaking capacity, type F (Europe), 1/2 A, 250 V fuse(s), or circuit-breaker as part of the installation.

Figure 2-5 Mains Power Supply

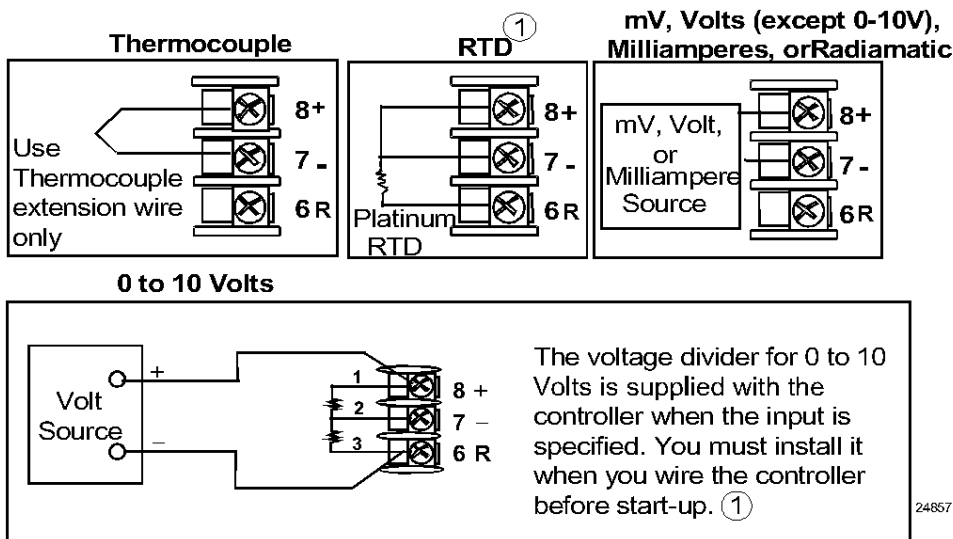

① These inputs are wired differently than the UDC2000

Figure 2-6 Input 1 Connections

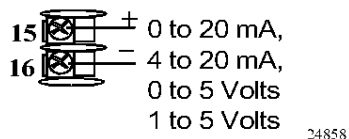

See “Preliminary Checks” in this section of the User Manual for jumper selections.

Figure 2-7 Input 2 Connections

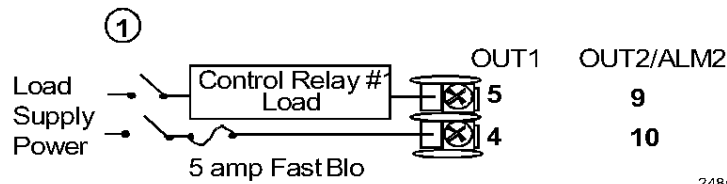

24859

- ① Control relays 1 and 2 are configured N.O. as shipped. Alarm relays 1 and 2 are configured N.C. as shipped. N.O. or N.C. configurations are selectable by jumpers on the Main printed wiring boards. See “Preliminary Checks” in this section of the User Manual for details. Each SPST relay is rated at 5A, 120 Vac and 30 Vdc, 2.5 A 240 Vac. User-provided fuses should be sized accordingly. For solid state relay outputs, see Figure 2-12.

See Figure 2-14 for Alarm and Duplex Output Connections.
See Table 2-2 and Table 2-3 for Control and Alarm Relay Contact information.

Figure 2-8 Electromechanical Relay Output

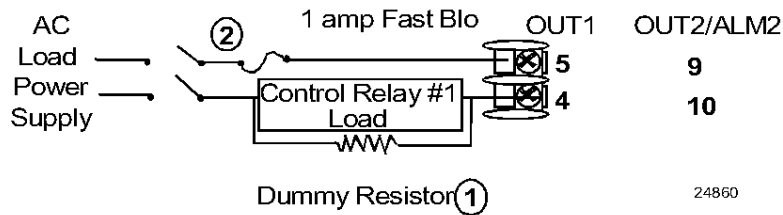

24860

- ① If the load current is less than the minimum rated value of 20 mA, there may be a residual voltage across both ends of the load even if the relay is turned off. Use a dummy resistor as shown to counteract this. The total current through the resistor and the load current must exceed 20 mA.
- ② Solid State relay is rated at 1 Amp at 25°C, linearly derated to 0.5 Amp at 55°C. Customer should size fuse accordingly.

See Figure 2-14 for Alarm and Duplex Output Connections.
See Table 2-2 and Table 2-3 for Control and Alarm Relay Contact information.

Figure 2-9 Solid State Relay Output

Customer Supplied External Electromechanical Relay

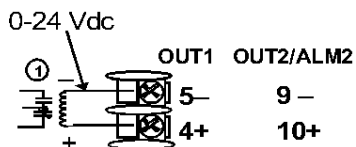

Customer Supplied External Solid State Relay

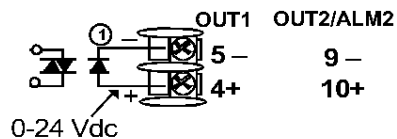

24861M

- ① **CAUTION** Open collector outputs are internally powered at 24 Vdc. Connecting an external supply will damage the controller. External relays should be fused between power and relay load.

See Figure 2-14 for Alarm and Duplex Output Connections.
See Tables 2-2 and 2-3 for Control and Alarm Relay Contact information.

Figure 2-10 Open Collector Relay Output

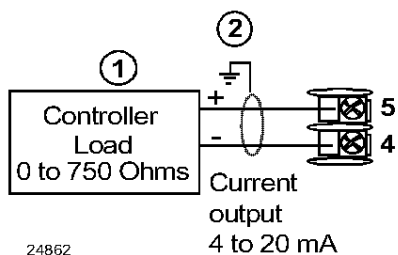

24862

- ① **CAUTION** Installing a current output instrument into a case wired for relay outputs will damage the instrument.
- ② Connect shield to ground at one end only.
- ③ Set output jumper per Figure 2-2.

See Figure 2-14 for Alarm and Duplex Output Connections.
See Table 2-2 and Table 2-3 for Control and Alarm Relay Contact information.

Figure 2-11 Current Output

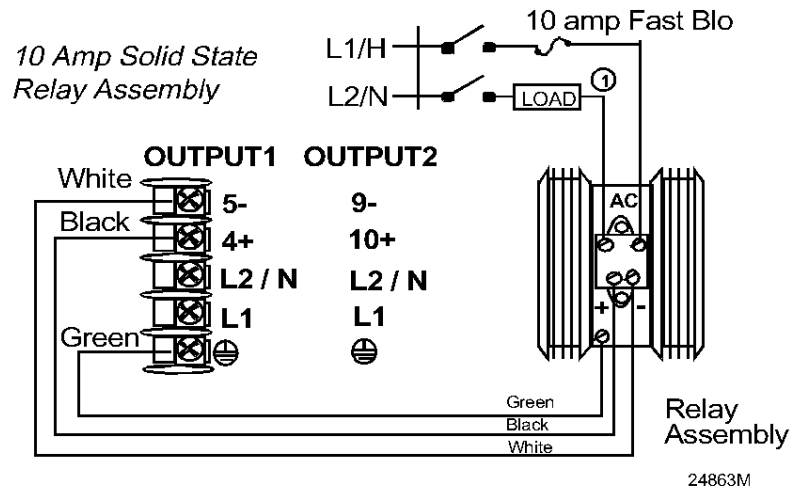

① This Solid State relay is rated at 15 Amps at 25°C, linearly derated to 10 Amps at 55°C. Customer should size fuse accordingly

Figure 2-12 External Solid State Relay Option (Internal Open Collector Output)

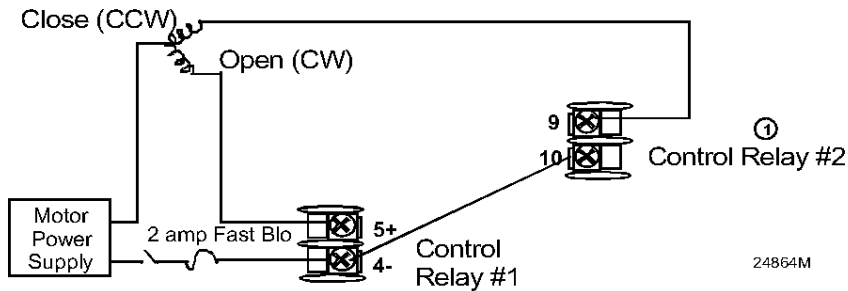

① Alarm #2 is not available with Three Position Step Control.

See Figure 2-14 for Alarm and Duplex Output connections.

Figure 2-13 Three-Position Step Control Connections

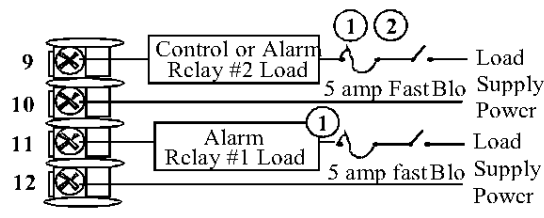

24867

- ① Control relays 1 and 2 are configured N.O. as shipped. Alarm relays and 2 are configured N.C. as shipped. N.O. or N.C. configurations are selectable by jumpers on main printed wiring boards. See "Preliminary Checks" in this sections of the User Manual for details. Each SPST relay is rated at 5 A, 120 Vac and 30 Vdc, 2.5 A, 240 Vac.
- ② Alarm #2 not available for Time Proportional Duplex or Three Position Step Control.

Figure 2-14 Alarm and Duplex Output Connections

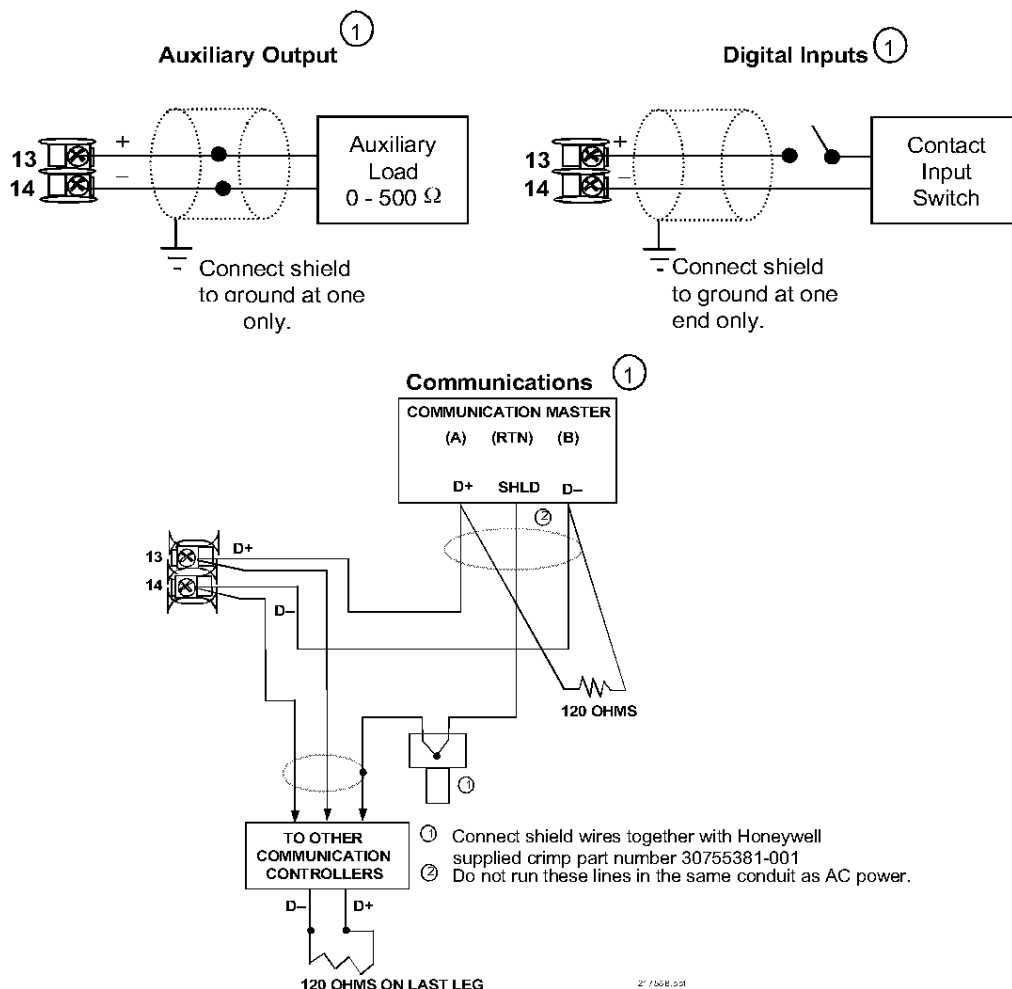

- ① AuxOut , Digital Input and Communications are mutually exclusive.

Figure 2-15 External Interface Option Connections

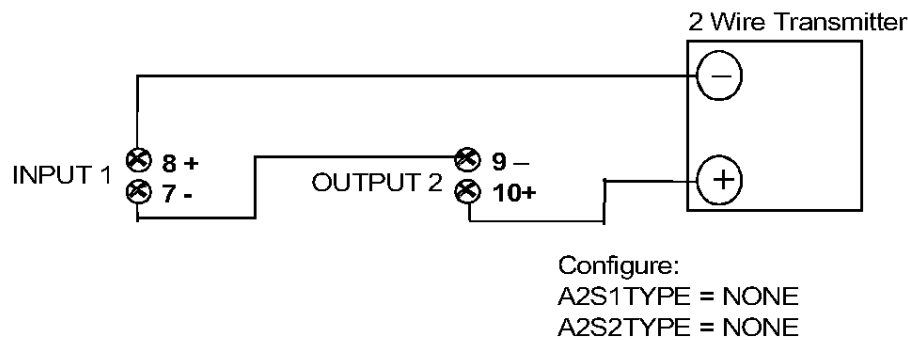

Figure 2-16 Transmitter Power for 4-20 mA — 2 wire Transmitter Using Open Collector Alarm 2 Output (Model DC230B-XT-XX-XX-XXXXXXX-XX-X)

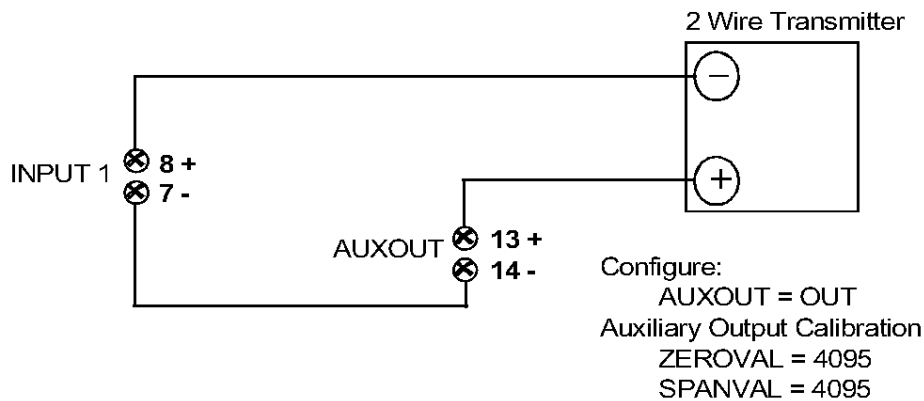

Figure 2-17 Transmitter Power for 4-20 mA — 2 Wire Transmitter Using Auxiliary Output (Model DC230B-XX-2X-XX-XXXXXXX-XX-X)

2.7 Initial Start-up

Overview

This section gives you the information necessary to start up your controller prior to configuration. Review the Operator Interface portion (Subsection 2.8) to make sure you are familiar with the indicator definitions and key functions.

Apply Power

When power is applied, the controller will run three diagnostic tests. After these tests are completed, "TEST DONE" is displayed.