DR 4500A Circular Chart Recorder Kit Instruction

Auxiliary Output Printed Circuit Board Kit (Part Number 51404561-501 or 51404561-503)

Form: 44-45-33-52A
Effective: 5/98

Summary

Enclosed with this instruction is a new Auxiliary Output printed circuit board for your DR4500A Recorder (Classic or Truline models).

Use the procedures listed in the tables to install, configure, and calibrate the Auxiliary Output Printed Circuit board. These procedures assumes that you are familiar with the DR4500A recorder. We suggest that you have a copy of the recorder's product manual on hand for reference.

ATTENTION Kit Part Number 51404561-503 contains a printed circuit board that has both Auxiliary output and RS485 Modbus RTU functions. Refer to Instruction Sheet 44-45-33-58 for information on the RS485 Modbus RTU function.

WARNING Never access components inside the case with the power applied.

CAUTION When handling electronic assemblies, care should be taken to avoid damage by electrostatic discharge. Use a wrist strap connected to an earth ground before withdrawing the printed circuit board from its container and installing it into the recorder.

Kit Contents

This kit contains parts to add Auxiliary Output to your DR4500A recorder. You kit you have received contains the following parts:

Part Number	Description
51404561-001 or 51404561-003	Auxiliary Output PCB or Auxiliary Output/Modbus RTU Communications PCB
30756005-001	Card Guide (2)
30755139-002	Terminal Block - 2 Position
30366609-004	Tie Wraps (2)

NOTE: You may wish to change or add Table III in your recorder's model number to equal 1XX to show that the recorder is equipped with the Auxiliary Output function, or 4XX to show that the recorder is equipped with the Auxiliary Output and Modbus RTU Communication function.

Continued on next page

Auxiliary Output Installation

Installation Procedure Follow the steps listed in Table 1 to add the 4-20mA Auxiliary Output printed circuit board. The procedure assumes that the chart door is open, the chart plate is swung out, and the **power is removed**.

Table 1 Adding a 4-20mA Auxiliary Output PCB

Step	Action
1	Install the new card guides supplied with the kit into proper location on the motherboard located in the left hand side of the case. (See Figure 1 for Auxiliary Output card location) CAUTION Install the guides with a steady pressure. Excessive rocking will destroy its latch.
2	Slide the new Auxiliary Output board into the card guides and press in firmly to seat the connector onto the motherboard.
3	Connect the 2-wire slate colored connector lead from the transformer on the motherboard to the Auxiliary Output board at J4. (See Figure 1 for location) If required, redress the leads from the Motherboard with the tie wraps provided in the kit.
4	Locate connector J2 near the bottom of the Auxiliary Output printed circuit board (See Figure 1 for location).
5	Run the output wires through the desired knockout.
6	Strip 1/4-inch maximum of insulation from the end of each wire.
7	Loosen the screws in terminals on the plug connector supplied in the kit and position the plug as you would to plug it into J2 on the Auxiliary Output board.
8	Observing the polarity, insert the wires into the appropriate screw clamps as shown in Figure 1. Tighten the screws to secure the wires.
9	Install the wired plug into J2
10	Configure the recorder for Auxiliary Output. Refer to Tables 2 and 3.
11	Make sure that the Auxiliary Output is calibrated. Refer to Tables 4 and 5.

Continued on next page

Auxiliary Output Installation, Continued

Installation Procedure, continued Figure 1 shows the location of the Auxiliary Output components.

Figure 1 Auxiliary Output Components

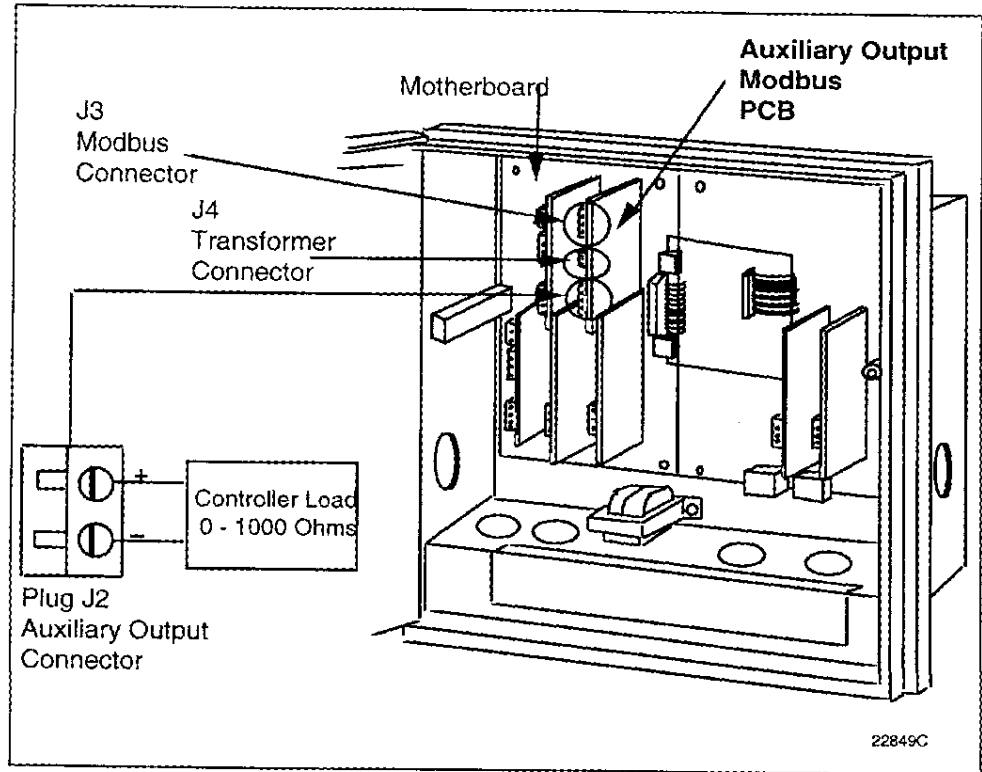









Continued on next page

Auxiliary Output Configuration

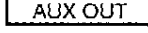
Enable auxiliary output The procedure to enable Auxiliary Output is listed in Table 2.

Table 2 Procedure for Enabling Auxiliary Output

Step	Operation	Press	Action/Result
1	Access the Options Set Up group		Until you see: Upper Display  Lower Display 
2	Access the Aux Out Prompt		Until you see: Upper Display  Lower Display 
3	Select a Parameter	 or 	To select what the Auxiliary Output will represent. It can represent any of twelve control parameters. See Table 3 for available parameter selections and definitions.
4	Return to normal operation		to return to normal operation.

Continued on next page

Auxiliary Output Configuration, Continued

Parameter selections Table 3 lists the available Auxiliary Output Selections and their definitions.

Table 3 Auxiliary Output Selection and Definitions

Lower Display Prompt	Upper Display Range of Setting or Selection	Parameter Definition
AUX OUT		<p>AUXILIARY OUTPUT SELECTION provides an mA output representing any of twelve control parameters. The display for auxiliary Output viewing will be in engineering units for all but output. Output will be designated in percent (%).</p> <p>Other prompts affected by these selections: "4 mA VAL" and "20mA VAL".</p>
	DISABL	<p>NO AUXILIARY OUTPUT</p>
	IN 1	<p>INPUT 1—This represents the configured range of input 1. FOR EXAMPLE: Type "J" Thermocouple (0 to 1600°F) 0°F display = 0% output 1600°F display = 100% output</p>
	IN 2	<p>INPUT 2 represents the value of the configured range of input 2.</p>
	PV 1	<p>PROCESS VARIABLE 1—Represents the value of the Process Variable for Loop 1. PV = Input 1 + Bias</p>
	DEV 1	<p>DEVIATION 1 (PROCESS VARIABLE MINUS SETPOINT)—Represents -100 to +100% of the selected PV span in engineering units for Loop 1. FOR EXAMPLE: Type "T" Thermocouple PV range = -300 to +700°F PV span = 1000°F Deviation range = -1000 to +1000°F If PV = 500°F and SP = 650°F then Deviation Display = -150°F Auxiliary Output = 42.5%</p> <p>NOTE: A deviation of 0°F yields an auxiliary output of 50%.</p>
	OUT 1	<p>OUTPUT 1—Represents the displayed controller output in percent (%) for Loop 1.</p>
	SP 1	<p>SETPOINT 1—Represents the value of the setpoint in units of PV for Loop 1.</p>
	PV 2	<p>PROCESS VARIABLE 2—Represents the value of the process variable for Loop 2.</p>
	DEV 2	<p>DEVIATION 2 (PROCESS VARIABLE MINUS SETPOINT)—Represents -100 to +100% of the selected PV span for Loop 2.</p> <p>See Example at DEV 1.</p>

Table 3 is continued on next page

Auxiliary Output Configuration, Continued

Parameter selections,
continued

Table 3 Auxiliary Output Selection and Definitions continued

Lower Display Prompt	Upper Display Range of Setting or Selection	Parameter Definition
AUX OUT (continued)	OUT 2 SP 2 IN 3 IN 4	<p>OUTPUT 2—Represents the displayed controller output in percent (%) for Loop 2.</p> <p>SETPOINT 2—Represents the value of the setpoint in units of PV for Loop 2.</p> <p>INPUT 3—Represents the value of the configured range of Input 3.</p> <p>INPUT 4—Represents the value of the configured range of Input 4.</p>
4 mA VAL	Low Scale Value within the range of the selected variable to represent 4 mA	<p>AUXILIARY OUTPUT LOW SCALING FACTOR—Use a value in engineering units for all selections above except Output.</p> <p>Use value in percent (%) for Output. (Output can be between -5 and +105%.)</p>
20mA VAL	High Scale Value within the range of the selected variable to represent 20 mA	<p>AUXILIARY OUTPUT HIGH SCALING FACTOR—Use a value in engineering units for: Input 1, Input 2, Process Variable, Deviation,* and Setpoint.</p> <p>Use a value in percent (%) for Output. (Output can be between -5 and +105%.)</p> <p>*When Deviation is selected, only one operating parameter will be entered. This value represents the deviation level that will produce 20 mA output. Zero deviation will produce a center scale (12 mA) output. A negative deviation equal in magnitude to the Auxiliary Output High Value will produce a low end (4 mA) output.</p>

Auxiliary Output Calibration

Introduction

Calibrate the recorder so that the auxiliary output provides the proper amount of current over the desired range.

- The recorder can provide an auxiliary output current range of from 0 to 21 milliamperes and can be calibrated at 4 mA for 0% of output and 20 mA for 100% of output or any other values between 0 and 21 mA.

Equipment needed

You will need a standard shop type milliammeter, with whatever accuracy is required, capable of measuring 0 to 20 milliamps.

Calibrator connections Refer to Figure 2 and wire the recorder according to the procedure given in Table 4.

Table 4 Set Up Wiring Procedure for Auxiliary Output

Step	Action
1	With the power off, door open, and the chart plate swung out; tag and disconnect field wiring from the plug in connector J2 on the auxiliary output PCB (see Figure 2).
2	Observing polarity, connect a milliammeter's leads to the plug for connector J2.
3	Close the chart plate; apply power and allow the recorder to warm up 15 minutes before you calibrate.

Figure 2 Test Equipment Connections for Calibrating Auxiliary Output

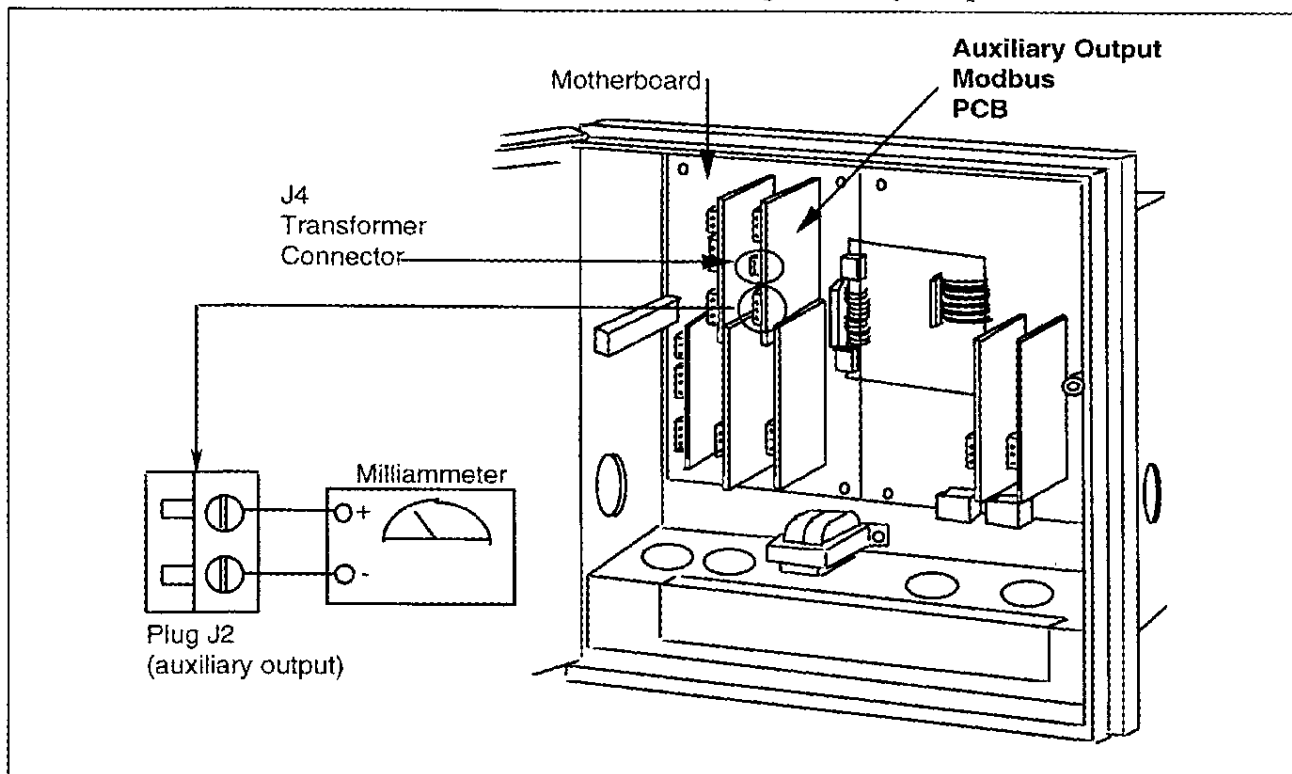













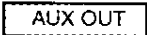

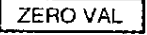
Continued on next page

Auxiliary Output Calibration, Continued

Procedure

The procedure for calibrating the Auxiliary Output is listed in Table 5. Make sure "LOCKOUT" in the Set Up group is set to "NONE." Also, "AUX. OUT" must NOT be disabled in the "Options" Set Up group. 11

Table 5 Auxiliary Output Calibration Procedure

Step	Description	Press	Action/Result
1	Enter Calibration Mode	 until you see	Upper Display  Lower Display 
2	Calibrate 0%		You will see: Upper Display  a value Lower Display 
		 or 	Until the desired 0% (4 mA) output is read on the milliammeter.
3	Calibrate 100%		Stores the 0% value and, you will see: Upper Display  a value Lower Display 
		 or 	Until the desired 100% (20 mA) output is read on the milliammeter.
4	Exit the Calibration Mode		The recorder stores the span value.
		 or 	To exit the calibration mode.