

# DR4200 GP Configuration

## Selecting the Input Actuation Type/Range

You must configure the recorder to accept the desired input actuation for the given pen by setting DIP switch S9 positions and positioning the applicable range jumpers on the Main printed circuit boards for Pen #1 and Pen #2, if applicable.

Note the configured actuation type for each pen on the wiring label on the back of the chart plate.

**ATTENTION** Be sure that a matching sensor input is wired to the input terminals.

**ATTENTION** Switch S9-Position 1 is OFF, DO NOT CHANGE.

Actuation Switch Settings and Jumper Locations

Actuation	Type	S9 Switch Positions and Settings			Range Jumper Locations
		2	3	4	
Thermocouple	J	OFF	ON	ON	W8, W9, W12
Thermocouple	K	OFF	ON	OFF	W8, W9, W12
Thermocouple	T	OFF	OFF	ON	W7, W9, W12
RTD*	100 Ohm*	OFF*	OFF*	OFF*	W6, W8, W12*
Linear	0-20mA	ON	OFF	OFF	W4, W8, W11
Linear	4-20 mA	ON	OFF	ON	W4, W8, W11
Linear	0-20 mV	ON	ON	ON	W7, W12
Linear	0-50 mV	ON	ON	OFF	W8, W12
Linear	0-5 Vdc	ON	OFF	OFF	W8, W11
Linear	1-5 Vdc	ON	OFF	ON	W8, W11

\* Factory setting

You can select Upscale or Downscale burnout for *Thermocouple* or *Millivolt* actuations. This means that the pen will be driven to its full upscale or downscale position if the Process Variable (PV) goes out-of-range (open input sensor) or the recorder detects a self-check failure.

**ATTENTION** You can select downscale burnout for RTD, Voltage, and mA actuations, but there is no guarantee that an out-of-range PV condition will be detected.

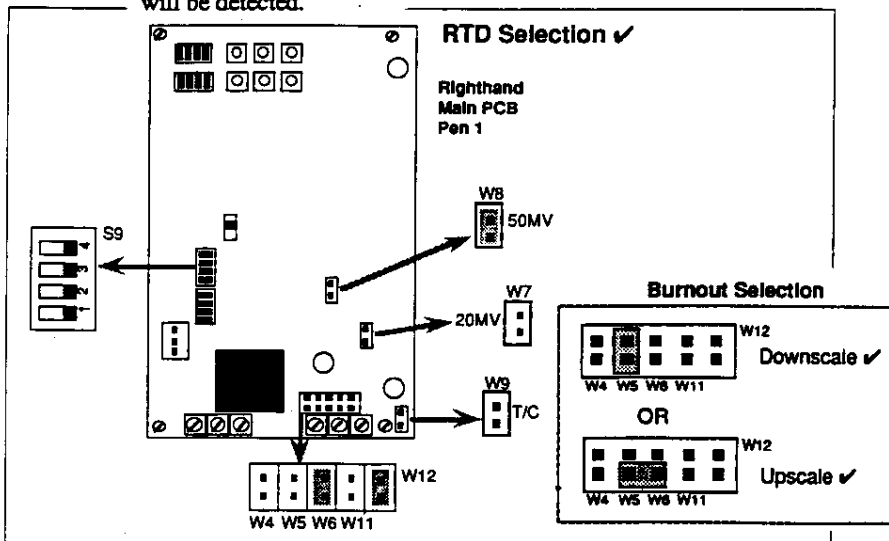

# DR 4200 GP Configuration

## DIP Switch Settings for Chart Zero and Full Scale Values (Linear Actuators)

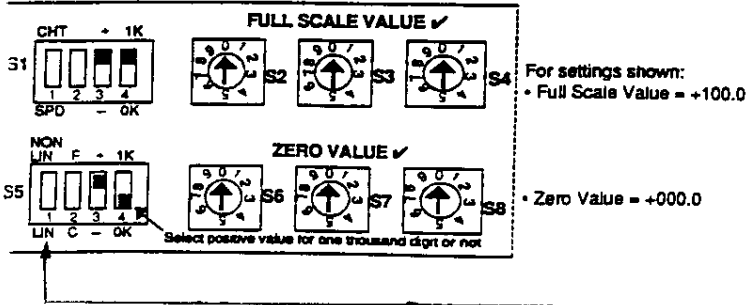

## DIP Switch Settings for Chart Zero and Full-Scale Values (T/C or RTD Actuators)

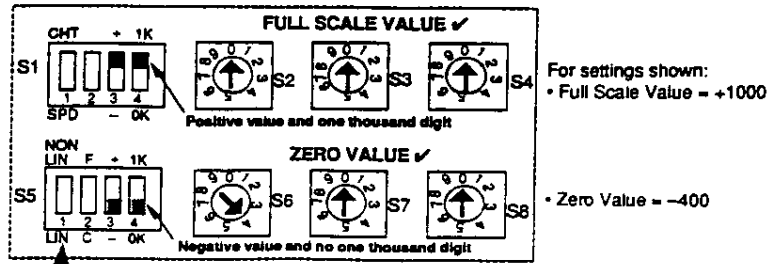

For Linear inputs (0-5V, 1-5V, 0-20 ma, 4-20ma, 0-10mv, etc.) zero and full scale value settings are multiplied by 0.1  
 Typical settings are 0.0% and 100.0% respectively.

For direct Thermocouple and RTD inputs, the zero and full scale settings equal the actual chart range (ie -400 to +1000)

### Chart Linearity Selections

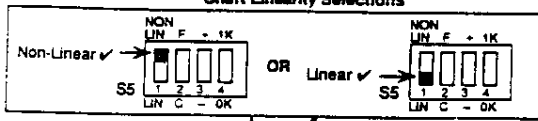

### Chart Linearity

Linear = Even charts  
 Non-linear = T/C or PT charts

### Chart Speed Selection

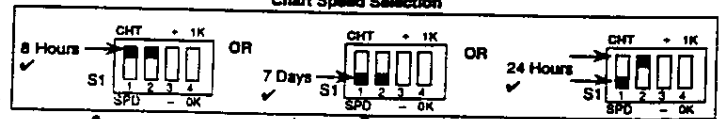

### Temperature Unit Selections

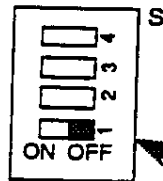
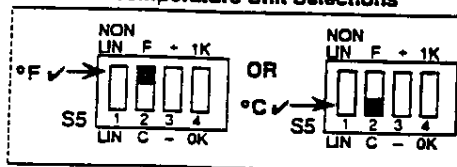

### Power Selection

