

# Configuration Selections for Relay Output

## Introduction

If you ordered a recorder with relay output, a separately packaged Output printed circuit board is supplied with your recorder. You must mount the Output printed circuit board on the Main printed circuit board, and make some configuration selections to set up the relay output function.

There are six configuration selections that you must make or check to get the recorder to operate in accordance with your application needs.

- Relay 1 Action (N.O. / N.C.)
- Relay 1 Type
- Relay 1 Alarm/Control Setpoint
- Relay 2 Action (N.O. / N.C.)
- Relay 2 Type
- Relay 2 Alarm Setpoint

## Relay configuration definitions

Table 3-1 defines selections associated with relay configuration parameters.

Table 3-1 Relay Configuration Parameters

| Parameter    | Selection                   | Definition  |
|--------------|-----------------------------|---|
| Relay Action | Normally Open               | Refers to relay contacts being <b>OPEN</b> when the relay is de-energized.                  |
|              | Normally Closed             | Refers to relay contacts being <b>CLOSED</b> when the relay is de-energized.                |
| Relay Type   | A. ON-OFF Control (Direct)  | Relay is <b>ENERGIZED</b> when the Process Variable (PV) is <b>ABOVE</b> the Setpoint (SP). |
|              | B. ON-OFF Control (Reverse) | Relay is <b>ENERGIZED</b> when the PV falls <b>BELOW</b> the SP.                            |
|              | C. High Alarm               | Relay is <b>DE-ENERGIZED</b> when the PV is <b>ABOVE</b> the SP.                            |
|              | D. Low Alarm                | Relay is <b>DE-ENERGIZED</b> when the PV is <b>BELOW</b> the SP.                            |
|              | E. High Limit Control*      | Same as High Alarm, but remains <b>DE-ENERGIZED</b> until <b>MANUALLY</b> reset.            |
|              | D. Low Limit Control*       | Same as Low Alarm, but remains <b>DE-ENERGIZED</b> until <b>MANUALLY</b> reset.             |

\* These only operate with thermocouple and RTD inputs.

# Mounting the Optional Relay Output Board

## Introduction

If you ordered a recorder with relay output, you must mount the Relay Output printed circuit board on the Main printed circuit board. Refer to Figure 3-3 and follow the procedure in Table 3-3 to mount the board.

**ATTENTION** Be sure that you have set all the jumper positions on the Main printed circuit board before proceeding.  
See Section 2 - Recording Set Up.

Figure 3-3 Mounting the Output Printed Circuit Board on the Main Printed Circuit Board

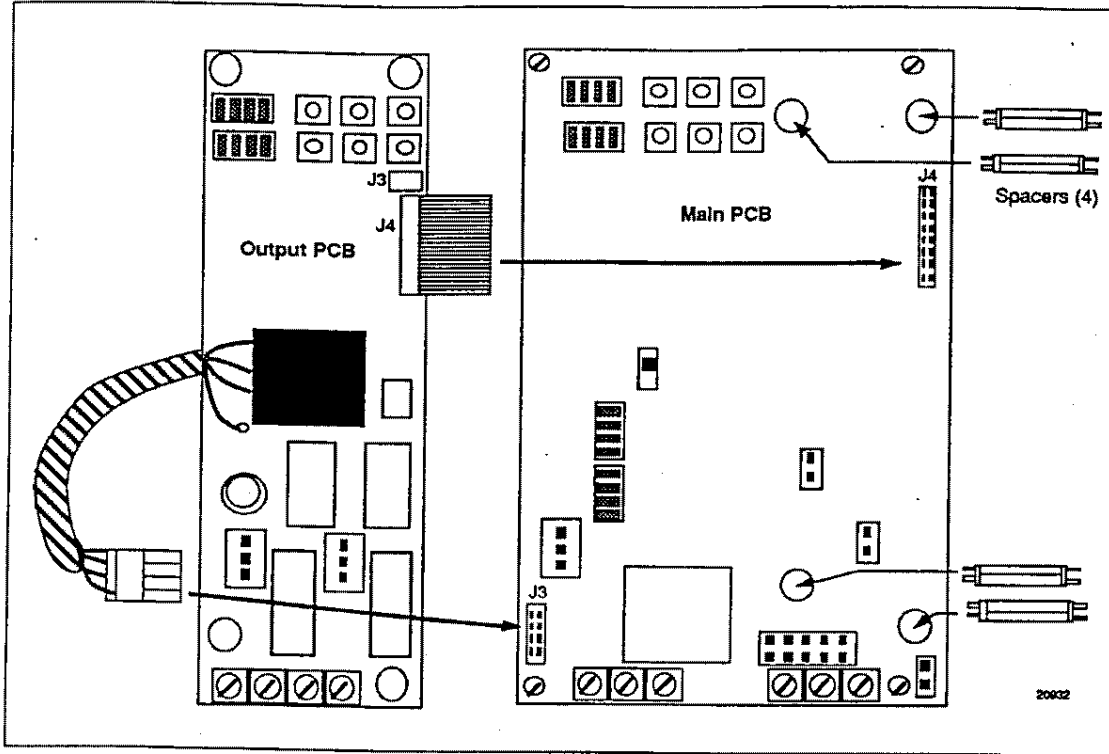

## Procedure

Follow the procedure in Table 3-3 to mount the Relay Output printed circuit board.

**ATTENTION** If Table I in the model number is 11, 22, or FF, repeat this procedure for the Main printed circuit board for Pen #2.

Table 3-3 Procedure for Mounting Relay Output Printed Circuit Board

| Step | Action  |
|------|---|
| 1    | Push the four plastic spacers (supplied with Output printed circuit board) into the holes on the right side of the Main printed circuit board for Pen #1 or Pen #2.   |
| 2    | Hold the Output printed circuit board so that its mounting holes align with the spacers and plug the multi-pin connector from the Output printed circuit board into J4 connector on the Main printed circuit board.<br><br>Be sure that the plug positions are aligned and matched with the pins on J4. |
| 3    | Push down on each corner of the Output printed circuit board in turn to seat the board on the spacers.  |
| 4    | Plug the 4-pin connector from the transformer on the Output printed circuit board into the J3 connector on the Main printed circuit board.  |

# Overview of Optional Relay Output Printed Circuit Board DIP Switch and Jumper Location

## Introduction

Depending on the number of relays specified in Table I of the model number, you can configure the relay output function through the DIP switches on the Output PCB to be one of the following:

| Output Function   | Model Selection Table I = |
|---|---------------------------|
| Relay #1 is for ON/OFF Control & Relay #2 is for Alarm  | 20 or 22                  |
| Relays #1 and #2 are for Alarms                         | 20 or 22                  |
| Relay #1 is for Alarm, ON/OFF Control, or Limit Control | 10, 11, FO, or FF         |

Figure 3-4 is an overview of the DIP switch and jumper locations. Each location references a figure that contains the information you need to check or set the switches and jumpers.

Figure 3-4 Overview of Relay Output DIP Switch and Jumper Locations

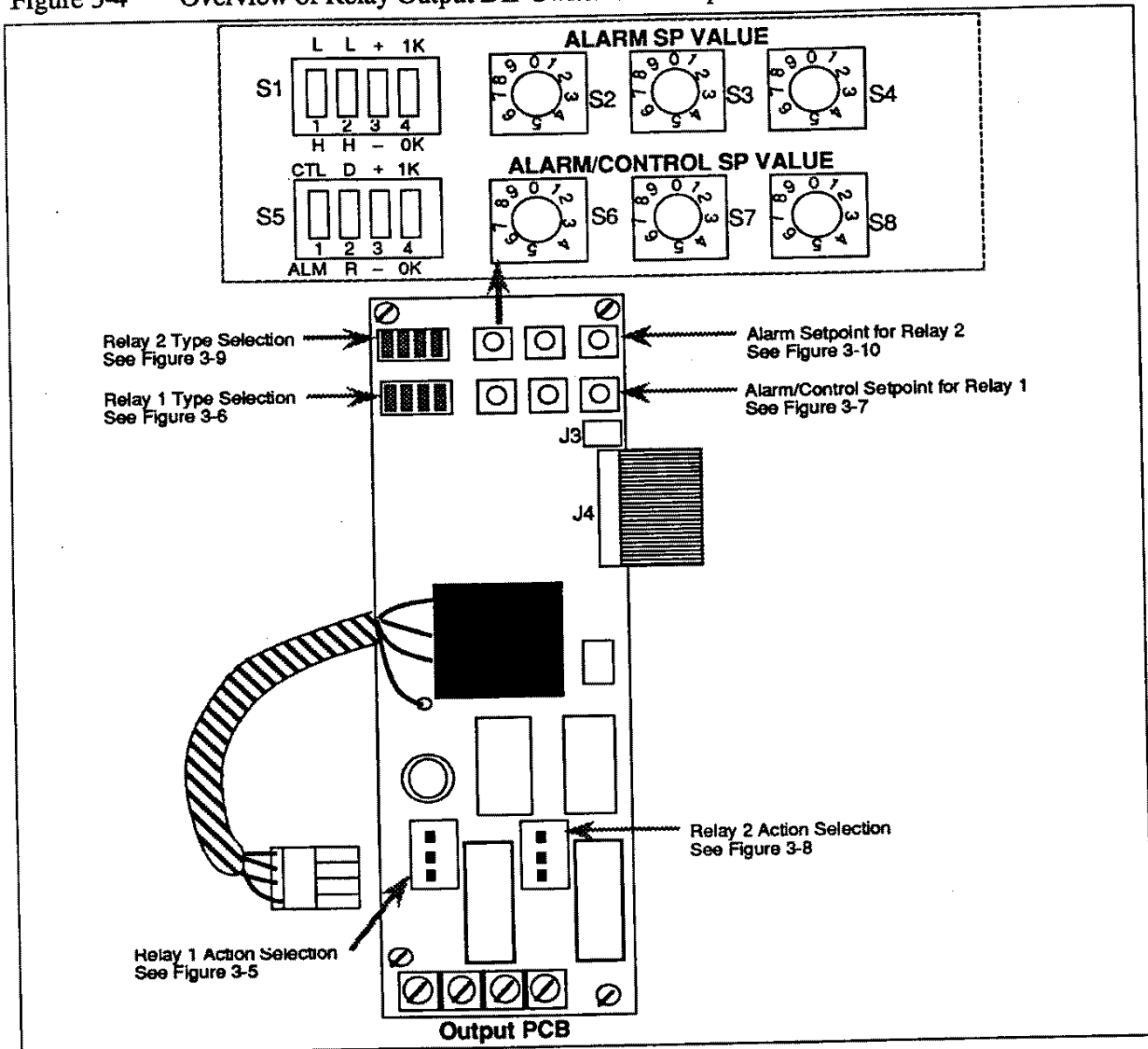

# Selecting Relay #1 Action

## Introduction

Figure 3-5 is a graphic view of the jumper locations for setting Relay #1 Action. Select the Output relay action as N.O. or N.C as shown in this figure. Note the selected action on the wiring label on the back of the chart plate for future reference.

This selection also applies for the Output PCB on the Main PCB for Pen #2, if Table I is 11, 22, or FF.

Figure 3-5 Jumper Locations for Relay #1 Action

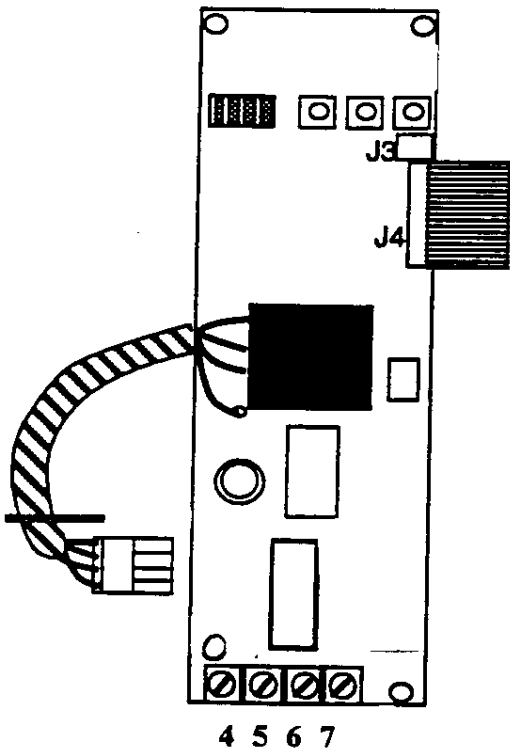
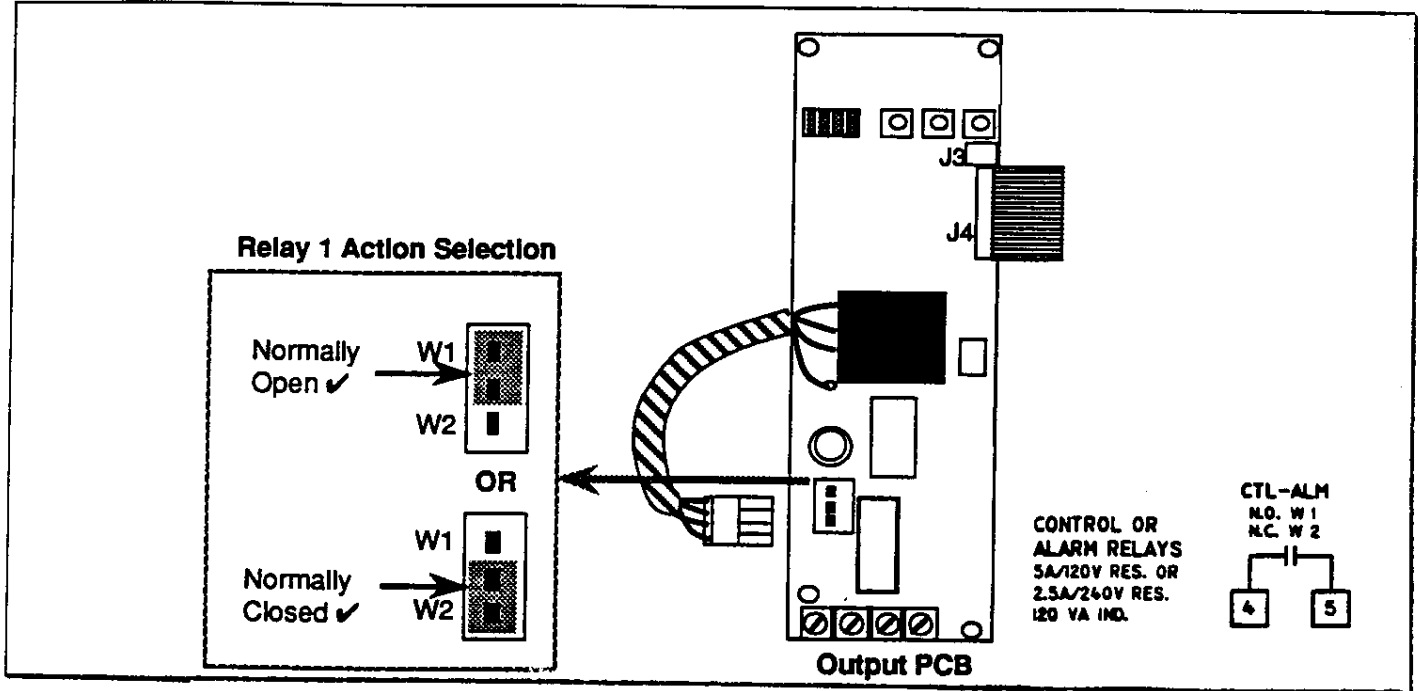

**Note:** Single relay output boards manufactured after September 1996 provide both a NC and NO contact at the terminal strip. The W1/W2 jumper has been removed from the circuit board.

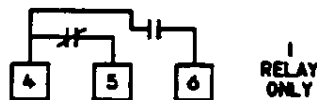

# Selecting Relay #1 Type

## Introduction

Figure 3-6 is a graphic view of the jumper locations for selecting Relay #1 Type. Set the DIP switches at location S5 as shown in this figure to select the desired Relay #1 Type. The selection can be one of the following:

- ON/OFF Control - Direct Action
- ON/OFF Control - Reverse Action
- High Alarm
- Low Alarm
- High Limit Control
- Low Limit Control

Note the selected action on the wiring label on the back of the chart plate for future reference.

**ATTENTION** If you select Limit Control refer to Figure 3-11 to install the manual reset switch required for Limit Control.

Figure 3-6 DIP Switch Settings for Relay #1 Type

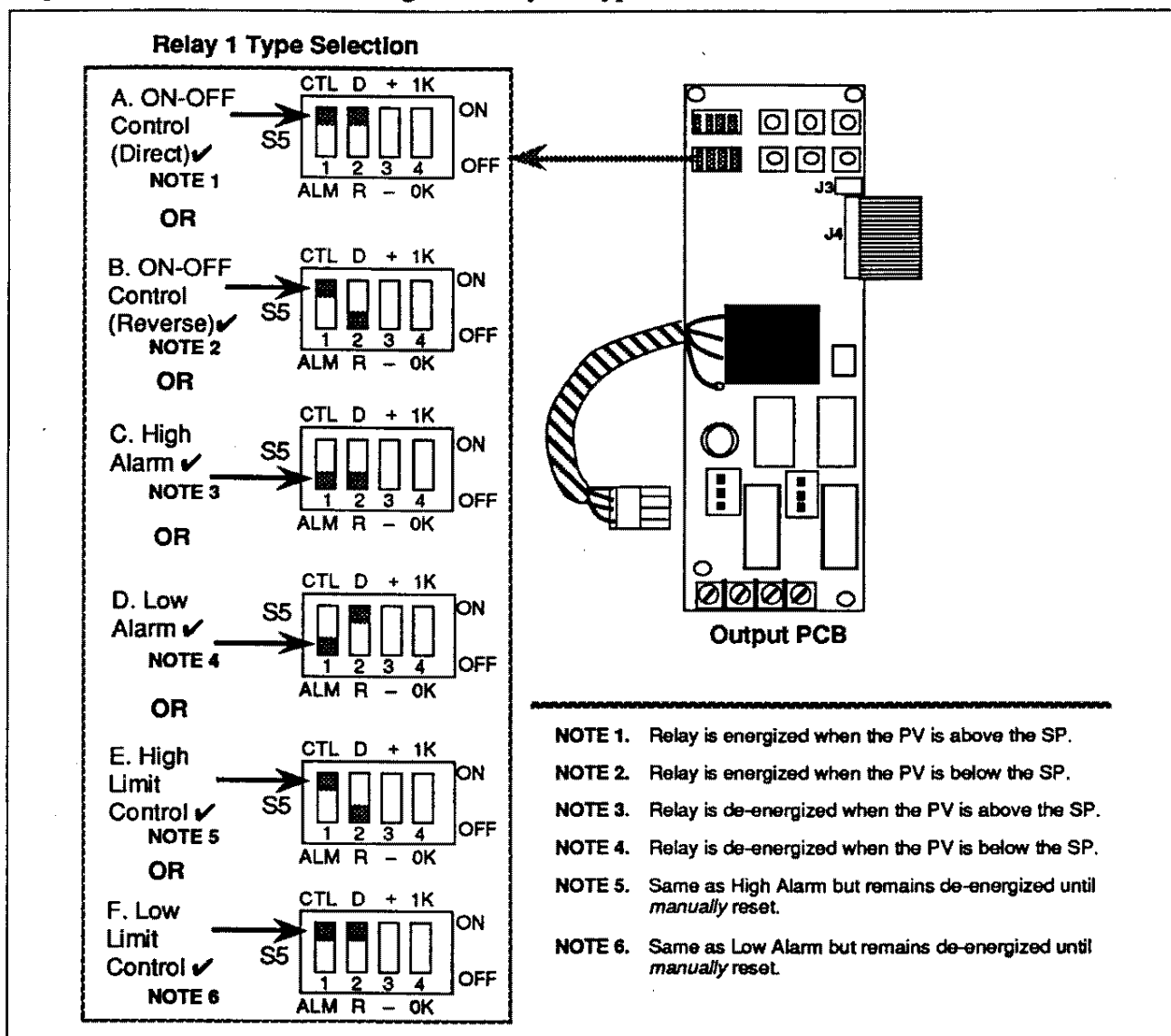

# Selecting Relay #1 Alarm/Control Setpoint

## Introduction

You select the Relay #1 Setpoint for one of the Relay #1 types you have selected:

- Direct or Reverse acting ON/OFF control output
- High or Low Limit Control
- High or Low PV Alarm

## Setpoint Value Limits

The setpoint value must be within the zero- and full-scale range for a given actuation type.

**Be sure to use 0-100% scale values for linear inputs instead of actual measurement range values, and multiply the switch settings by 0.1 as for chart range values.**

## ON/OFF control

ON/OFF control operates on the sign of the error signal. Thus, for direct acting control, the output is ON whenever the PV is greater than the Setpoint; and for reverse acting control the output is ON whenever the PV is less than the Setpoint.

## Hysteresis

Both the control and alarm actions have a fixed hysteresis of 1% of the chart range. This means that the output will turn ON at exactly the Setpoint value, but it won't turn OFF until the PV equals the SP minus the hysteresis value. The relays will de-energize during a power loss allowing this condition to be alarmed.

## Procedure

Figure 3-7 is a graphic view of the S5 DIP switch settings and rotary switch locations for Control/Alarm setpoints. Follow the procedure in Table 3-4 and make the settings as shown in this figure.

Table 3-4 Selecting Relay #1 Alarm/Control Setpoint

| Step | Action   |
|------|--|
| 1    | Locate DIP switch S5 in the upper left corner of the Output printed circuit board for Pen #1 or Pen #2.  |
| 2    | Set position 3 to up/ON for a positive value, or down/OFF for a negative one.  |
| 3    | Set position 4 to up/ON for one thousand digit, or down/OFF for a zero thousand digit.   |
| 4    | Turn the arrow in the center of the rotary DIP switches S6, S7, and S8 to point to the desired number for 100, 10, and 1 digit places in Control or Alarm SP value for Relay #1. |

# Selecting Relay #1 Alarm/Control Setpoint, Continued

DIP switch and rotary switch locations

Figure 3-7 is a graphic view of the S5 DIP switch settings and rotary switch locations for Control/Alarm setpoints.

Figure 3-7 Relay #1 Control/Alarm Setpoints DIP Switch Settings

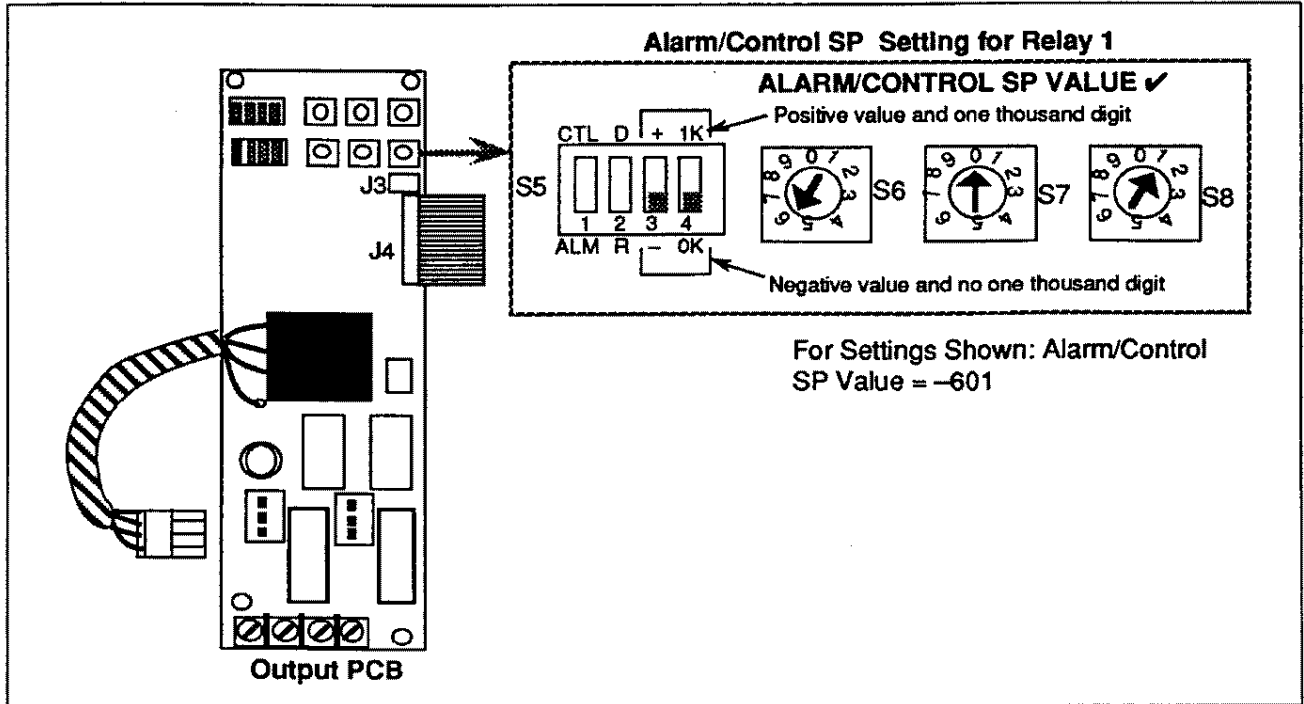

# Selecting Relay #2 Action

## Introduction

Figure 3-8 is a graphic view of the jumper locations for setting Relay #2 Action (Model Table I is 20 or 22 only). Select the Output relay action as N.O. or N.C. as shown in this figure. Note the selected action on the wiring label on the back of the chart plate for future reference.

- This selection also applies for the Output printed circuit board on the Main printed circuit board for Pen #2, if Model Table I is 22.

Figure 3-8 Jumper Locations for Relay #2 Action

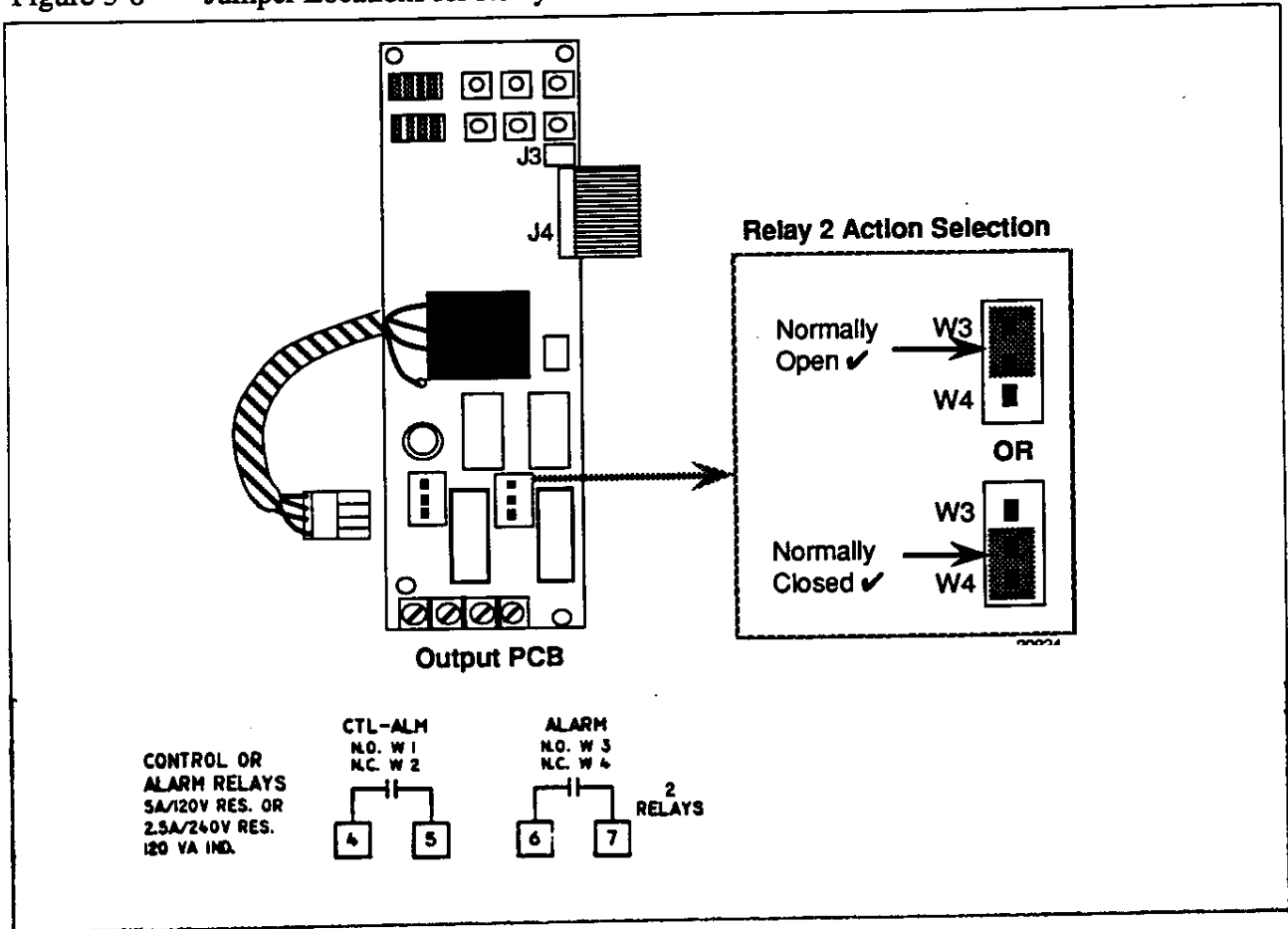

# Selecting Relay #2 Type

## Introduction

Figure 3-9 is a graphic view of the jumper locations for selecting Relay #2 Type. Set the DIP switches at location S1 as shown in this figure to select the desired Relay #2 Type. The selection can be one of the following:

- High Alarm Type
- Low Alarm Type

Note the selected action on the wiring label on the back of the chart plate for future reference.

Figure 3-9 DIP Switch Settings for Relay #2 Type

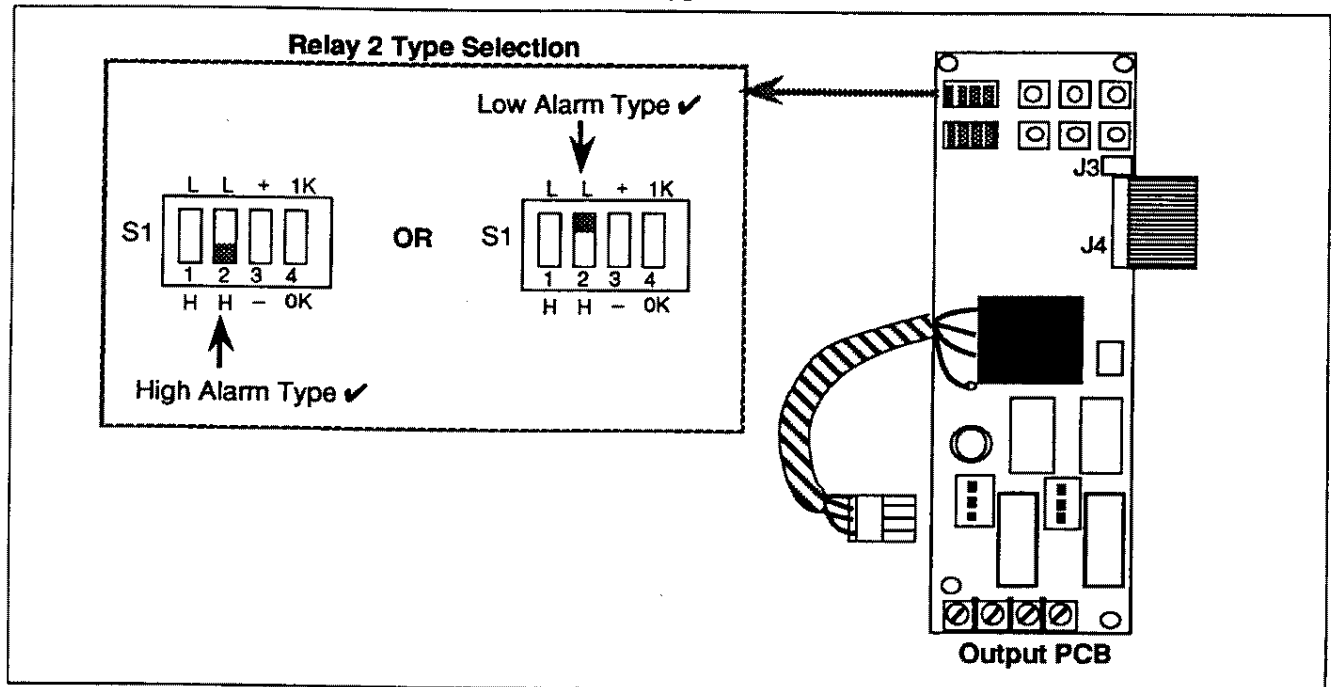

# Selecting Relay #2 Alarm Setpoint

## Introduction

You select the Relay #2 Alarm Setpoint for one of the Relay #2 types you have selected:

- High Alarm Type
- Low Alarm Type

## Hysteresis

Both the control and alarm actions have a fixed hysteresis of 1% of the chart range. This means that the output will turn ON at exactly the Setpoint value, but won't turn OFF until the PV equals the SP minus the hysteresis value. Also, alarms will still turn ON when power is removed from the recorder.

## "No" alarm condition

A "NO" alarm condition energizes the alarm relay. Thus, if you want the relay to de-energize on an alarm condition, be sure to use the W4 jumper (refer to Figure 3-8).

## Procedure

Figure 3-10 is a graphic view of the S1 DIP switch settings and rotary switch locations for Alarm setpoints. Follow the procedure in Table 3-5 and make the settings as shown in this figure.

Table 3-5 Selecting Relay #2 Alarm Setpoint

| Step | Action  |
|------|---|
| 1    | Locate DIP switch S1 in the upper left corner of the Output printed circuit board for Pen #1 or Pen #2.   |
| 2    | Set position 3 to up/ON for a positive value, or down/OFF for a negative one.   |
| 3    | Set position 4 to up/ON for one thousand digit, or down /OFF for a zero thousand digit.   |
| 4    | Turn the arrow in the center of the rotary DIP switches S2, S3, and S4 to point to the desired number for 100, 10, and 1 digit places in Alarm SP value for Relay #2. |

Figure 3-10 Relay #2 Alarm Setpoints DIP Switch Settings

