

## 1. Calibration

This chapter covers the field calibration procedures for the inputs, outputs and various functions of the DCP216 controller after shipment from the factory. When calibration is made in the field, the original factory data is erased, and so the specified input/output accuracies of the controller cannot be assured. This manual is for users who are conversant with DCP216 use and operation.

## 2. Precautions before calibration

Apply power and allow the controller to warm up for 2 hours before you calibrate the DCP216. Confirm that the test equipment needed for calibration have stabilized.

Factory calibration has been made at a stable temperature of 23.0°C (±2°C). Calibrate the DCP216 in this range, and where there are no significant fluctuations in air temperature. For cold junction adjustment of thermocouple input, do not expose the terminals to moving air.

Perform calibration item 7 of Table 17-1 before any other calibrations, if it is to be done.

You must write newly calibrated data to EEPROM before exiting from calibration mode, otherwise all new data will be lost.

If calibration equipment of a lower grade than specified below are used, calibration results may be unsatisfactory.

## 3. Equipment needed

- (1) Standard input source with ±0.02% accuracy (having more than 5 effective digits and is capable of generating both voltage and current outputs)
- (2) Decade resistance box with ±0.02% accuracy (having a range of 10 to 300Ω with a resolution of more than 0.01Ω)
- (3) Digital ammeter with ±0.02% accuracy (measurable in the range of 4 to 20 mA with assured resolution of more than 0.01 mA)
- (4) Thermometer with accuracy greater than 0.1°C (measurable at room temperature with assured resolution of more than 0.1°C)

## 4. Calibration procedures

### 4.1 Enter calibration mode

- ① Release keylock. (SETUP C1=0)
- ② Press **DISP** key to permit ordinary indication condition. Change to READY (RUN and HOLD are off) and AUTO (MAN off) modes.

The following LEDs will illuminate after the above operations:

RUN LED is OFF.  
HOLD LED is OFF.  
MAN LED is OFF.

- ③ To enter calibration mode, hold down the **FUNC** key, and press **SET UP** key and **ENT** key simultaneously.

The display will show the symbols described in Figure 17-2.

If the indication is different, repeat the above procedure after pushing **DISP** key to refresh the display.

- ④ To select individual calibration items, press **▲** keypad to select the item by scrolling, then **SET UP** key, and **ENT** key.

The order of calibration items is described in Table 17-1.

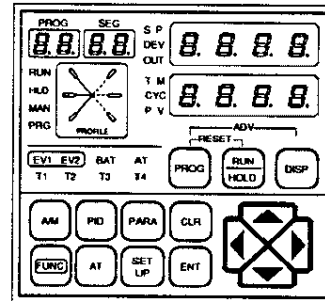

Figure 17-1

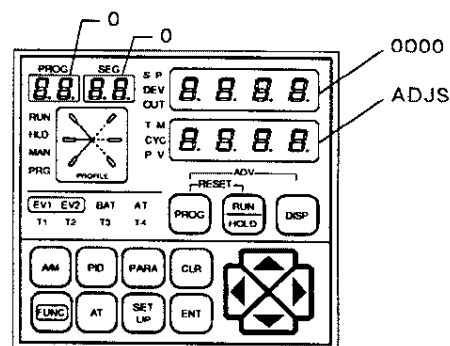
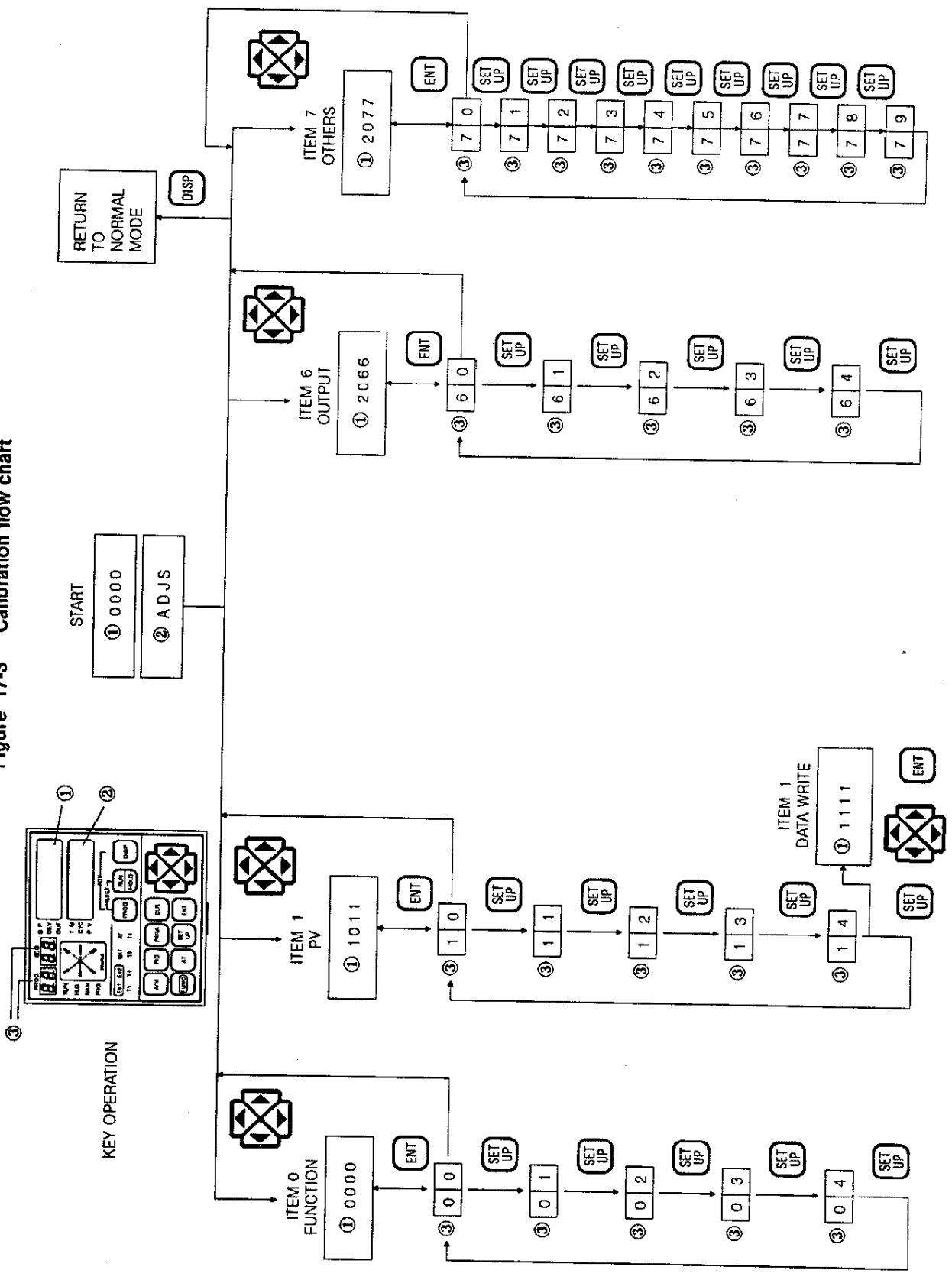

Figure 17-2



**Table 17-1 Item and Subitem Table for Calibration**

Item indicator PROG	Subitem indicator SEG	Description	Upper display shows	Lower display shows	
0	0	Item change code	0000, etc.	ADJS	
	1	Key test			
	2	Display test			
	3	Digital output test			
	4	RSW test			
1	0	Item change code	1011	ADJS	
	1	Sensor number			
	2	PV input 0%			] Previous adjustment value
	3	PV input 100%			
	4	Write to EEPROM			
6	0	Item change code	2066	ADJS	
	1	Current output 4mA			
	2	Current output 20mA			] Previous adjustment value
	3	Auxiliary output 4mA			
	4	Auxiliary output 20mA			
7	0	Item change code	2077	ADJS	
	1	A/D channel			
	2	Correction point 1			
	3	Correction point 2			
	4	Correction point 3			
	5	C/J short-circuit			
	6	C/J release			
	7	C/J terminal temperature			] Previous adjustment value
	8	RTD BC short-circuit			
	9	RTD AC short-circuit			

Figure 17-3 Calibration flow chart



#### 4.2 Controller function test procedures (ITEM 0)

Press  keypad to show (0000) on upper display then press  key.

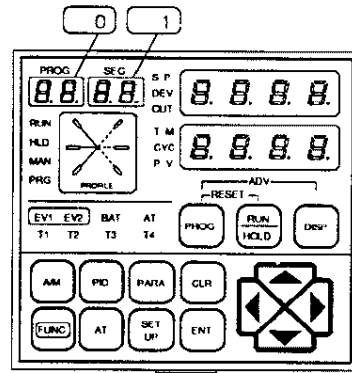



Figure 17-4

##### 4.2.1 Key test (0-1)

Press  key until PROG/SEG display shows (0-1). When you press each key, the data (shown in Figure 17-5) appears in the upper display.

















Key	Display	Key	Display	Key	Display
	0.0.0.1.		0.0.4.0.		0.8.0.0.
	0.0.0.2.		0.0.8.0.		2.0.0.0.
	0.0.0.8.		0.1.0.0.		4.0.0.0.
	0.0.1.0.		0.2.0.0.		
	0.0.2.0.		0.4.0.0.		

Figure 17-5

#### Cautions

1. When you press  key, calibration mode will be exited.
2. When you press  key, the next calibration menu will be entered (display test).

##### 4.2.2 Display test (0-2)

Press  key until RROG/SEG display shows (0-2).

Then each 7-segment LED lamp illuminates at every 1 sec. This is to check if each LED/LCD illuminates.

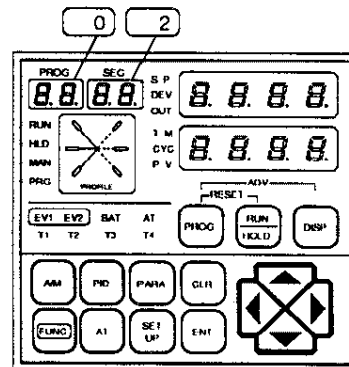

Figure 17-6

### 4.2.3 Digital output test (0-3)

Press **SET UP** key until PROG/SEG display shows (0-3).

Scroll using the **PROBLE** keypad to display the data shown in Tables 17-2, 17-3 on the upper display, so that each digital output is on.

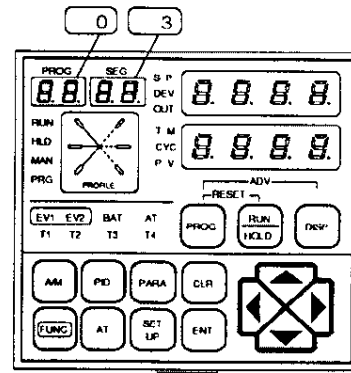

Figure 17-7

Table 17-2 Digital output event test

Upper display \ Output	EV1 ⑥ - ⑦	EV2 ⑧ - ⑨
0.0.0.0.	—	—
0.0.0.1.	ON	—
0.0.0.2.	—	ON
0.0.0.3.	ON	ON

- Note:
1. "—" in the table means "OFF".
  2. Since the EV1 and EV2 hardware is of relay output specification, the ON/OFF check must be performed in meeting with the specification.

Table 17-3 Digital output event test

Upper display \ Output	TM1 ③① - ③⑤	TM2 ③② - ③⑤	TM3 ③③ - ③⑤	TM4 ③④ - ③⑤	Upper display \ Output	TM1 ③① - ③⑤	TM2 ③② - ③⑤	TM3 ③③ - ③⑤	TM4 ③④ - ③⑤
0.0.0.0.	—	—	—	—	0.0.8.0.	—	—	—	ON
0.0.1.0.	ON	—	—	—	0.0.9.0.	ON	—	—	ON
0.0.2.0.	—	ON	—	—	0.0.A.0.	—	ON	—	ON
0.0.3.0.	ON	ON	—	—	0.0.b.0.	ON	ON	—	ON
0.0.4.0.	—	—	ON	—	0.0.C.0.	—	—	ON	ON
0.0.5.0.	ON	—	ON	—	0.0.d.0.	ON	—	ON	ON
0.0.6.0.	—	ON	ON	—	0.0.E.0.	—	ON	ON	ON
0.0.7.0.	ON	ON	ON	—	0.0.F.0.	ON	ON	ON	ON

- Note:
1. "—" in the table means "OFF".
  2. Since the TM1 to 4 hardware is of open collector output specification, the ON/OFF check must be performed in meeting with the specification.

4.2.4 RSW test (0-4)

Press **SET UP** key until PROG/SEG display shows (0-4).  
 When you turn on or off each remote switch, the upper display will show the data described in Table 17-4.

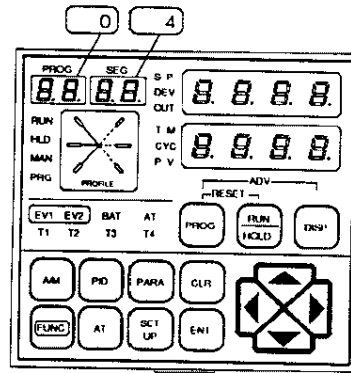

Figure 17-8

Table 17-4

Upper display \ Output	①9-②7	②0-②7	②1-②7	②2-②7	②3-②7	②4-②7	②5-②7	②6-②7
0.0.0.0.	—	—	—	—	—	—	—	—
0.0.0.1.	ON	—	—	—	—	—	—	—
0.0.0.2.	—	ON	—	—	—	—	—	—
0.0.0.4.	—	—	ON	—	—	—	—	—
0.0.0.8.	—	—	—	ON	—	—	—	—
0.0.1.0.	—	—	—	—	ON	—	—	—
0.0.2.0.	—	—	—	—	—	ON	—	—
0.0.4.0.	—	—	—	—	—	—	ON	—
0.0.8.0.	—	—	—	—	—	—	—	ON

Note: "ON" means to short the terminals by a jumper.  
 "—" means to open them.

(Example)

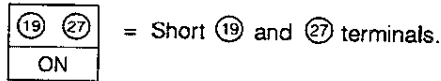

4.3 Procedure to input new values

Press **SET UP** key until (0000) appears in the upper display and (ADJS) appears in the lower display.

Scroll using the **⊠** keypad to show (2077) on the upper display, then press **ENT** key.

① A/D conversion correction point measurement

(a) Remove the seal attached on the right side of case.

(b) Press **SET UP** key to show (7-1) on the PROG/SEG display.

(c) Scroll using **⊠** keypad to show (0001) on the upper display, then press **ENT** key.

(d) Measure voltage  $V_1$  between terminals ② and ④ of lower connector (P8).

Note:  $V_1$  must be measured to more than 5 digits (x.xxxx...V)

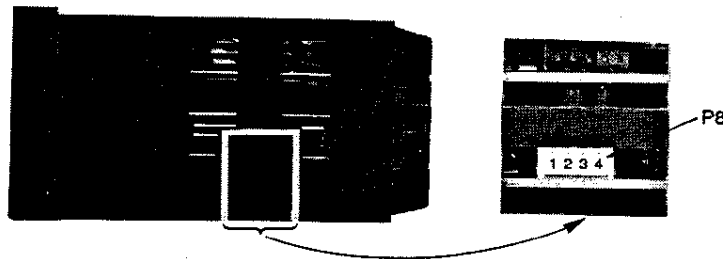









Table 17-9

- (e) Scroll using  keypad to show (0002) on the upper display, then press  key.
- (f) Measure voltage  $V_2$  between terminals ② and ④ of lower connector (P8).
- (g) Scroll using  keypad to show (0003) on the upper display, then press  key.
- (h) Measure voltage  $V_3$  between terminals ② and ④ of lower connector (P8).
- (i) Scroll using  keypad to show (0004) on the upper display, then press  key.
- (j) Measure voltage  $V_Z$  between terminals ② and ④ of lower connector (P8).
- (k) Scroll using  keypad to show (0007) on the upper display, then press  key.
- (l) Measure voltage  $V_R$  between terminals ② and ④ of lower connector (P8).

(m) Calculate  $d_{72}$ ,  $d_{73}$  and  $d_{74}$  using the following equations:









$$d_{72} = (V_1 - V_Z) + (V_R - V_Z) \times 32767 \quad (= \text{xxxxx.x...})$$

$$d_{73} = (V_2 - V_Z) + (V_R - V_Z) \times 32767 \quad (= \text{xxxxx.x...})$$

$$d_{74} = (V_3 - V_Z) + (V_R - V_Z) \times 32767 \quad (= \text{xxxxx.x...})$$

(n) Rounding up to the nearest integer, convert the results to hexadecimal to obtain  $D_{72}$ ,  $D_{73}$  and  $D_{74}$ .







$d_{72}$   $\longrightarrow$   $D_{72}$   
 $d_{73}$   $\longrightarrow$   $D_{73}$   
 $d_{74}$   $\longrightarrow$   $D_{74}$

- ② Enter correction point 1
  - (a) Press  key to show (7-2) on the PROG/SEG display.
  - (b) Enter  $D_{72}$  using  keypad (on the upper display), then press  key.
- ③ Enter correction point 2
  - (a) Press  key to show (7-3) on the PROG/SEG display.
  - (b) Enter  $D_{73}$  using  keypad (on the upper display), then press  key.
- ④ Enter correction point 3
  - (a) Press  key to show (7-4) on the PROG/SEG display.
  - (b) Enter  $D_{74}$  using  keypad (on the upper display), then press  key.





(Example)  
 Figures:  $V_1 = 1.9316V$   
 $V_Z = -0.007V$   
 $V_R = 4.8305V$

Calculation:  
 $d_{72} = \{1.9316 - (-0.007)\} + \{(4.8305) - (-0.007)\}$   
 $\times 32767$   
 $= 13102.75 \dots$   
 $= 13103$  (after rounding up)  
 Hexadecimal number:  $D_{72} = 332F$

**4.4 Thermocouple input model cold junction correction procedures.**

- ① When C/J is short-circuited:
  - (a) Press  key to show (7-5) on the PROG/SEG display.
  - (b) Short-circuit the terminals ⑳ and ㉓ then press  key after the display stabilizes.
- ② When C/J is released:
  - (a) Press  key to show (7-6) on the PROG/SEG display.
  - (b) Remove short circuit from the terminals ⑳ and ㉓ then press  key after the display stabilizes.
- ③ Input C/J terminal temperature:
  - (a) Press  key to show (7-7) on the PROG/SEG display.
  - (b) Measure the temperature of terminal ㉓ to an accuracy of 0.1°C by using the thermometer.
  - (c) Input the value in (b) using the  keypad (upper display).
  - (d) Press  key.

**4.5 Resistance temperature detector (RTD) wiring resistance correction procedures**

- ① If short-circuit occurs between RTD terminals ㉓ and ㉔: (Fig 17-10)
  - (a) Press  key to show (7-8) on the PROG/SEG display.
  - (b) Connect as shown in Figure 17-10, then press  key after the display stabilizes.
- ② If short-circuit occurs between RTD terminals ㉓ and ㉓: (Fig 17-11)
  - (a) Press  key to show (7-9) on the PROG/SEG display.
  - (b) Connect as shown in Figure 17-11 then press  key after the display stabilizes.

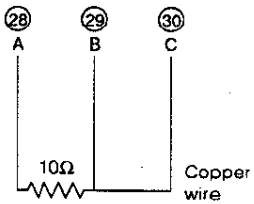

Figure 17-10

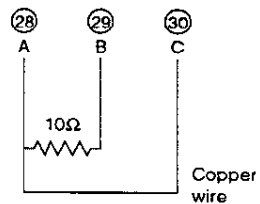





Figure 17-11



Note: The 3 copper wires must be identical in grade and length. Use the same 3 copper wires for the adjustment of (7-8) and (7-9) (this section) and (1-2) and (1-3) (section 4.6)

## 4.6 PV calibration procedures

Press  key until (0000) appears in upper display and (ADJS) appears in the lower display.



Scroll using the  keypad to show (1011) on the upper display, then press  key.

### 4.6.1 Input sensor number



- (a) Press  key to show (1-1) on the PROG/SEG display.
- (b) Input the sensor number to the upper display using the  keypad (refer to Table 17-5)
- (c) Press  key.

### 4.6.2 PV zero, span calibration procedures

#### ① PV zero calibration



- (a) Press  key to show (1-2) on the PROG/SEG display.
- (b) Input the zero value of input signal for your input type PV=0% (refer to Table 17-5)
- (c) Press  key after the display stabilizes. (It takes about 10 seconds to stabilize.)

#### ② PV span calibrations

- (a) Press  key to show (1-3) on the PROG/SEG display.
- (b) Input the span value of input signal for your input type PV=100% (refer to Table 17-5)
- (c) Press  key after the display stabilizes. (It takes about 10 seconds to stabilize.)

## 4.7 Data write procedure

#### ① Writing to EEPROM

- (a) Press  key to show (1-4) on the PROG/SEG display.
- (b) Input the value (1111) to the upper display using the  keypad then press  key. The data is written to EEPROM.

After (b) is implemented, a buzzer will sound and either the display goes blank or a portion of LED glows brighter. When this occurs, the calibration data from RAM is written to EEPROM. If this is not done, the calibration data will be lost, the original data will be restored.

Press  key to recover original display status.

Calibrate the DCP 216 controller for the minimum (0%) and maximum (100%) range values for your particular sensors. Select the voltage or resistance equivalent of 0% and 100% of range using Table 17-5.



**Table 17-5. Minimum & maximum range values**

Type	Input	No.	Range °C	PV 0%	PV 100%
T/C	B	0	0 to 1800	0 mV	13.585 mV
	E	1	0 to 800	0 mV	61.022 mV
	J	2	0 to 800	0 mV	45.498 mV
	K	3	0 to 1200	0 mV	48.828 mV
	R	4	0 to 1600	0 mV	18.842 mV
	S	5	0 to 1600	0 mV	16.771 mV
	T	6	-199.9 to +300.0	-5.6014 mV	14.860 mV
	W	7	0 to 2300	0 mV	36.922 mV
	PR40-20	8	0 to 1900	0 mV	5.031 mV
	N	9	0 to 1300	0 mV	47.502 mV
	PL2	10	0 to 1300	0 mV	52.2474 mV
	K	11	0 to 800	0 mV	33.277 mV
K	12	0.0 to 400.0	0 mV	16.395 mV	
RTD <sup>1</sup>	IECPt100 Ω	20	(-200 to +300)	18.49 Ω	280.9 Ω
	IECPt100 Ω	21	-199.9 to +200.0	18.534 Ω	175.84 Ω
	JISPt100 Ω	22	-199.9 to +200.0	17.183 Ω	177.13 Ω
	JISPt100 Ω	23	0.0 to 500.0	100.00 Ω	284.02 Ω
	JISPt100 Ω	24	-40.0 to +60.0	83.99 Ω	123.64 Ω
	JISPt100 Ω	25	-50.0 to +200.0	79.96 Ω	177.13 Ω
	JISPt100 Ω	26	-100.0 to +150.0	59.57 Ω	158.29 Ω
	JISPt100 Ω	27	0.0 to 300.0	100.0 Ω	213.93 Ω
	JISPt100 Ω	28	0.0 to 100.0	100.0 Ω	139.16 Ω
	IECPt100 Ω	29	0.0 to 500.0	100.0 Ω	284.02 Ω
	IECPt100 Ω	30	-40.0 to +60.0	83.99 Ω	123.64 Ω
	IECPt100 Ω	31	-50.0 to +200.0	79.96 Ω	177.13 Ω
	IECPt100 Ω	32	-100.0 to +150.0	59.57 Ω	158.29 Ω
	IECPt100 Ω	33	0.0 to 300.0	100.00 Ω	213.93 Ω
IECPt100 Ω	34	0.0 to 100.0	100.00 Ω	139.16 Ω	
Linear	C01	40	When shipped from factor 0 to 1000	1 mA	20 mA
	M01	41	0 to 1000	0 mV	10.0 mV
	L02	42	0 to 1000	-10 mV	10 mV
	V01	45	0 to 1000	1 V	5 V

- Notes: 1. Adjust one of: 23 or 29, 24 or 30, 25 or 31, 26 or 32, 27 or 33, 28 or 34.  
2. These values must be used for the PV zero span adjustments of Nos. 29 to 34 (IEC inputs and ranges).





## 4.8 Output calibration procedures

Press  key until (0000) appears in the upper display and (ADJS) appears in the lower display.





Use the  keypad to show (2066) on the upper display then press  key.

### 4.8.1 Control output calibration

#### ① Control output zero (4mA)





- (a) Press  key to show (6-1) on the PROG/SEG display.
- (b) Connect the ammeter to the control output terminals  and . (Fig. 17-5)
- (c) Use the  keypad to adjust the ammeter to show 4mA.
- (d) Press  key. Zero calibration is complete.

#### ② Control output span calibration (20mA)





- (a) Press  key to show (6-2) on the PROG/SEG display.
- (b) Connect the ammeter to the control output terminals  and .
- (c) Use the  keypad to adjust the ammeter to show 20mA.
- (d) Press  key. Span calibration is complete.

### 4.8.2 Auxiliary output calibration

#### ① Auxiliary output zero calibration (4mA)



- (a) Press  key to show (6-3) on the PROG/SEG display.
- (b) Connect the ammeter to the auxiliary output terminals  and . (Fig. 17-6)
- (c) Use the  keypad to adjust the ammeter to show 4mA.
- (d) Press  key. Zero calibration is complete.

#### ② Auxiliary output span calibration (20mA)



- (a) Press  key to show (6-4) on the PROG/SEG display.
- (b) Connect the ammeter to the auxiliary output terminals  and .
- (c) Use the  keypad to adjust the ammeter to show 20mA.
- (d) Press  key. Span calibration is complete.

4.8.3 Follow the next procedure to write the above data into EEPROM.

Press  key to change the display from (6-4) to (6-0).

Use the  keypad to show (1011) on the upper display, and then press  key. The PROG/SEG shows (1-0).

Press  key 4 times to show (1-4).

Use the  keypad to show (1111) on the upper display, and then press  key to complete the data write.

i. Setup

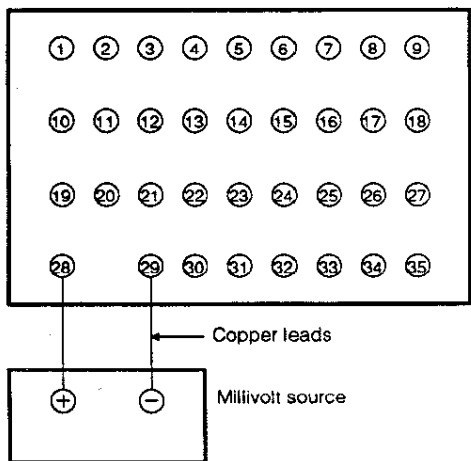

Figure 17-12 Thermocouple inputs

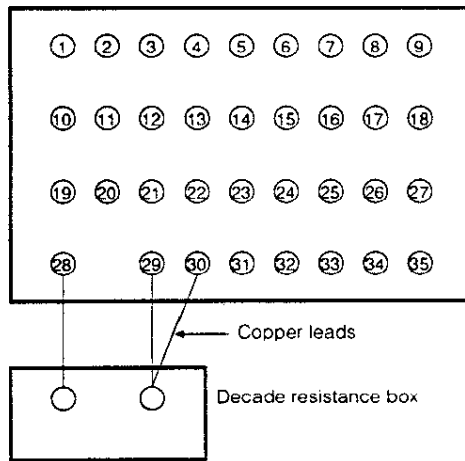

Figure 17-13 RTD inputs

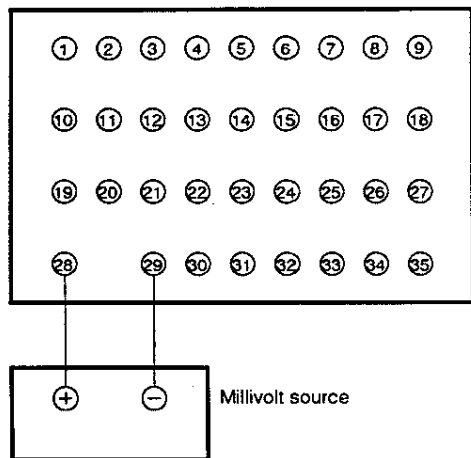

Figure 17-14 MV, V inputs

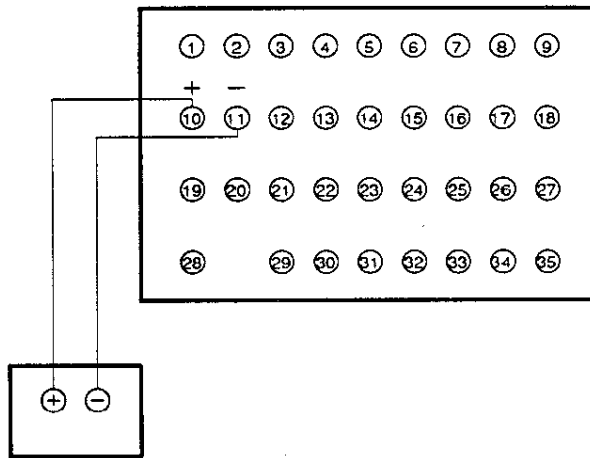

Figure 17-15 MV outputs

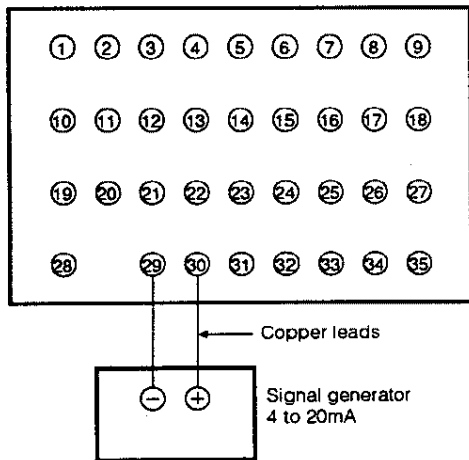

Figure 17-16 MA inputs

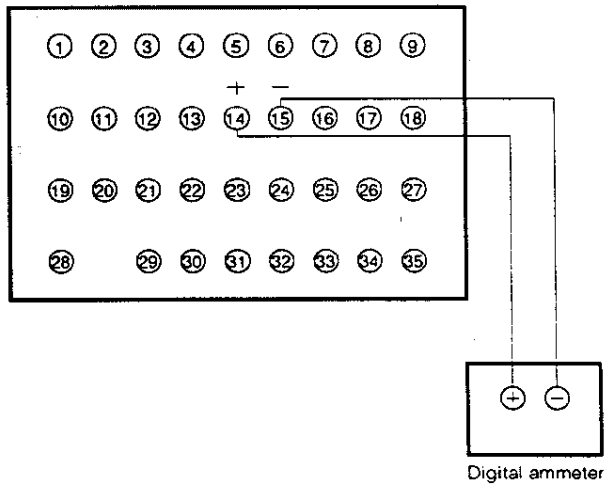

Figure 17-17 Auxiliary outputs