

WIRING

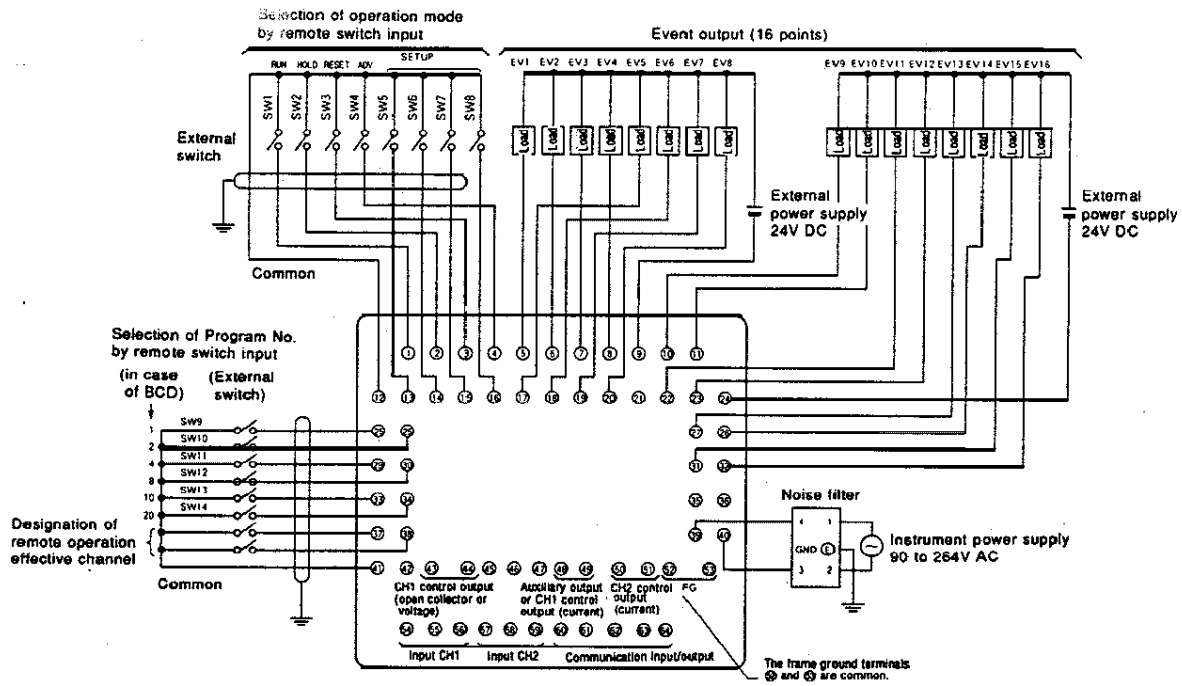

CH1 PV Input

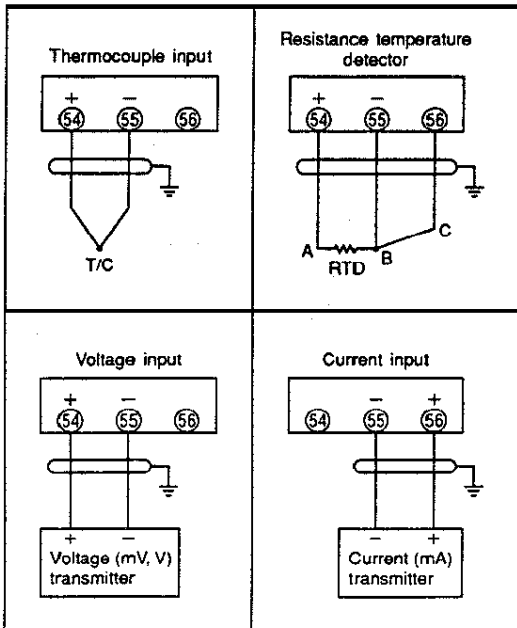

CH2 PV Input

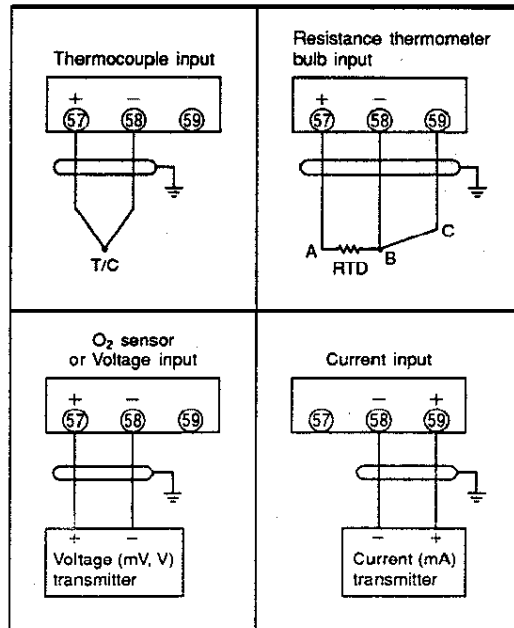

Caution

If a voltage mode signal is applied between the PV input CH1 terminals (terminal Nos. 55 and 56) or PV input CH2 terminals (terminal Nos. 58 and 59) for current input by mistake, a large current may flow, thus causing a trouble. After checking if a current signal within the range of 4 to 20mA is properly output from the current input source, connect it to the current input terminals of DCP552.

