

# Chapter 12. CALIBRATION

---

This chapter covers the field calibrations procedures for the inputs, outputs and various functions of the DCP551 mark II controller after shipment from the factory. When calibration is made in the field, the original factory data is erased, and so the specified input/output accuracies of the controller cannot be assured. This manual is for users who are conversant with DCP551 mark II use and operation.

## ■ Precautions before calibration

Apply power and allow the controller to warm up for 2 hours before you calibrate the DCP551 mark II. Confirm that the test equipment needed for calibration has stabilized. Factory calibration has been made at a stable temperature of 23.0°C ( $\pm 2^\circ\text{C}$ ). Calibrate the DCP551 mark II in this range, and where there are no significant fluctuations in air temperature.

You must write newly calibrated data to EEPROM before exiting from calibration mode, otherwise all new data will be lost.

If calibration equipment of a lower grade than specified below is used, calibration results may be unsatisfactory.

## ■ Equipment needed

- (1) Standard input source with  $\pm 0.02\%$  accuracy (having more than 5 effective digits and capable of generating both voltage and current outputs)
- (2) Decade resistance box with  $\pm 0.02\%$  accuracy (having a range of 10 to 300 $\Omega$  with a resolution of more than 0.01 $\Omega$ )
- (3) Digital ammeter with  $\pm 0.02\%$  accuracy (measurable in the range of 4 to 20mA with assured resolution of more than 0.01mA)
- (4) Thermometer with  $\pm 0.1^\circ\text{C}$  accuracy (resolution of more than 0.1 $^\circ\text{C}$ )

DCP551 mark II controllers are numbered using the following format. Format items may require different calibration procedures, as shown in Table 12-1.

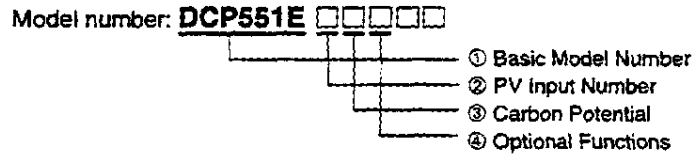

Table 12-1. Calibration Items for Each Model

Calibration & Test Item	Model	① Basic Model	② PV Input Number		③ Carbon Potential		④ Optional Functions			
			1	2	0	1	0	1	2	
			0	Function Test	Key Test	<input type="radio"/>				
		Indicator Test	<input type="radio"/>							
		DI Test	<input type="radio"/>							
		Control Output Test	<input type="radio"/>							
		DO Test	<input type="radio"/>							
		Clock Adjustment	<input type="radio"/>							
1	PV Input Calibration	Ch1		<input type="radio"/>	<input type="radio"/>					
		Ch2			<input type="radio"/>					
2	CJ Sensor Calibration	Ch1		<input type="radio"/>	<input type="radio"/>					
		Ch2			<input type="radio"/> *					
6	Current Output Calibration	Out Ch1	<input type="radio"/>							
		Out Ch2								
		AUX Ch1						<input type="radio"/>		<input type="radio"/>
		AUX Ch2								<input type="radio"/>

Note: \*, If this is Carbon Potential model (Carbon Potential Code = "1"), it isn't necessary to calibrate these items.

Table 12-2. Item and Sub Item Table for Calibration

Item	Sub Item	Description	Upper Display Shows	Lower Display Shows	
0	0	Item change code	0000, etc.	<i>AdJS</i>	
	1	Key test			
	2	Display test			
	3	Digital input test			
	4	Output test (control)			
	5	Output test (digital output)			
	6	Clock adjustment			
1	0	Item change code	1011		
	1	Channel No.			
	2	Gain No.			
	3	PV input 0%			
	4	PV input 100%			
	5	Write to EEPROM			1111
2	0	Item change code	2022	<i>AdJS</i>	
	1	CJ ch1 input 0%			Previous adjustment value
	2	CJ ch1 input 100%			
	3	CJ ch1 count			
	4	CJ ch1 temperature			
	5	CJ ch2 input 0%			
	6	CJ ch2 input 100%			
	7	CJ ch2 count			
	8	CJ ch2 temperature			
	9	Write to EEPROM			
6	0	Item change code	6066	<i>AdJS</i>	
	1	OUT ch1 4mA output			Previous adjustment value
	2	OUT ch1 20mA output			
	3	OUT ch2 4mA output			
	4	OUT ch2 20mA output			
	5	AUX ch1 4mA output			
	6	AUX ch1 20mA output			
	7	AUX ch2 4mA output			
	8	AUX ch2 20mA output			
	9	Write to EEPROM			

- Notes:**
1. Items No. is shown on the PROG display.
  2. Sub item No. is shown on the SEG display.
  3. Item 0: Function check item except sub item No. 6
  4. Items 1, 2, 6 and clock adjustment of item No. 0. : Calibration items

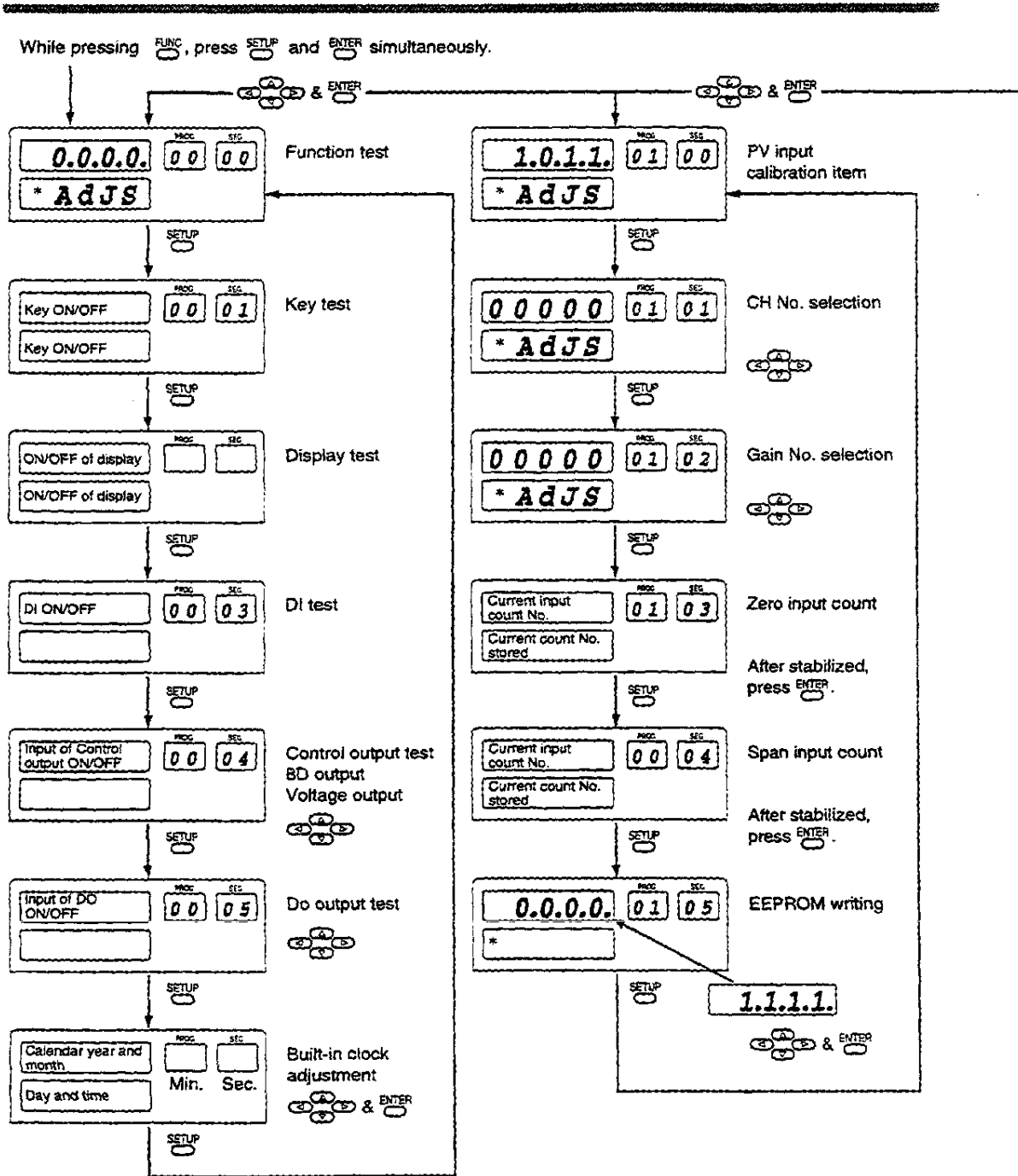

**Notes:** \*; 1. This display shows the digits shown in the previous indication.  
 2. If wrong key operation is made when moving from one to another item, the display is returned to the initial status of calibration mode. But, the mode is still in the calibration mode.

Figure 12-1. Calibration Flowchart (1/3)

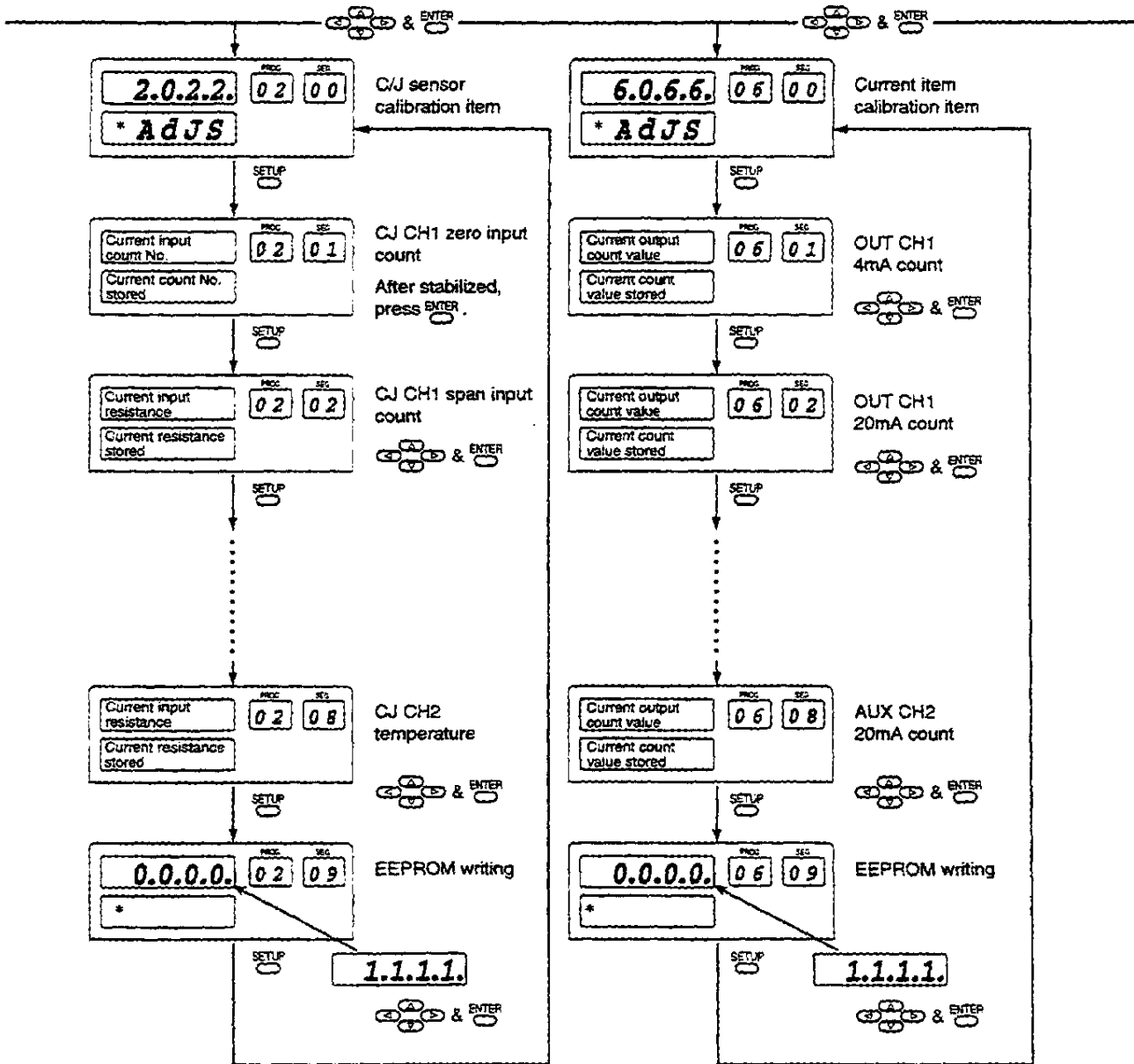

Figure 12-1. Calibration Flowchart (2/3)

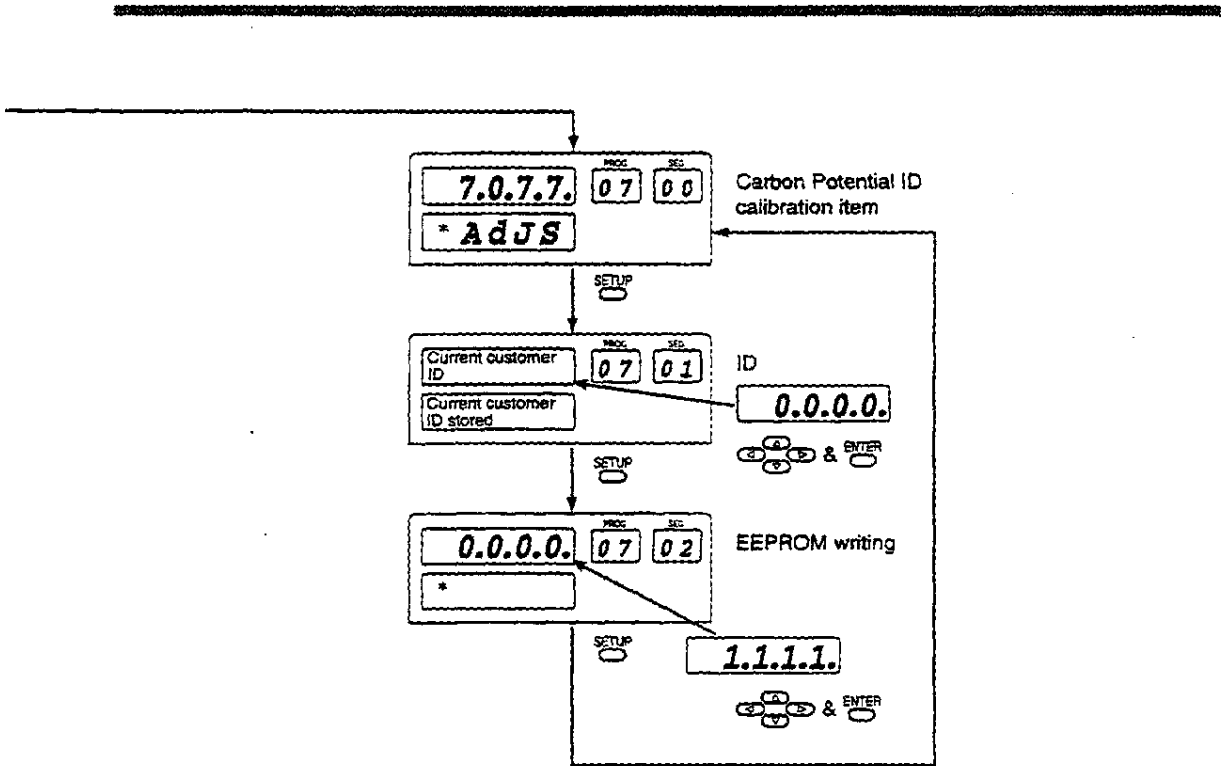

Figure 12-1. Calibration Flowchart (3/3)

## 12-2 Calibration Procedures

### ■ Enter calibration mode

- ① Release keylock. (**PARA PA01=0**)
- ② Press **DISP** key to permit ordinary indication condition.  
Change to **READY** (**RUN** and **HLD** are off) and **AUTO** (**MAN** off) modes.  
The following LEDs will illuminate after the above operations.  
**RUN LED** is OFF  
**HLD LED** is OFF  
**MAN LED** is OFF

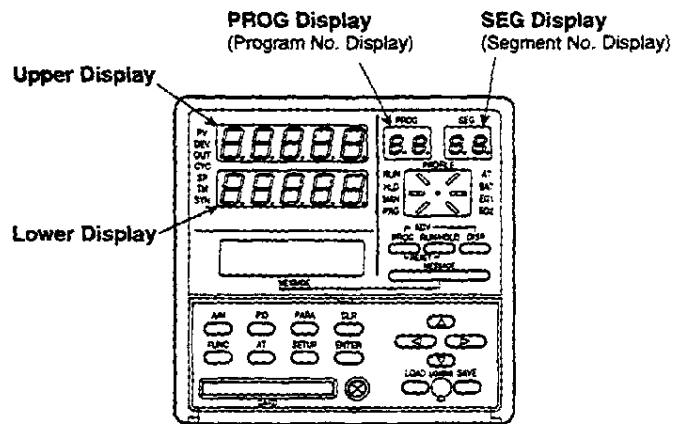

Figure 12-2.

- ③ To enter calibration mode, hold down the **FUNC** key, and press **SETUP** key and **ENTER** key simultaneously.  
The display will show the symbols described in Figure 12-3. If the indication is different, repeat the above procedure after pushing **DISP** key to refresh the display.
- ④ To select individual calibration items, press **↑**, **↓**, **←**, or **→** keys to select the item by scrolling, then **SETUP** key, and **ENTER** key.  
The order of calibration items is described in Table 12-2.

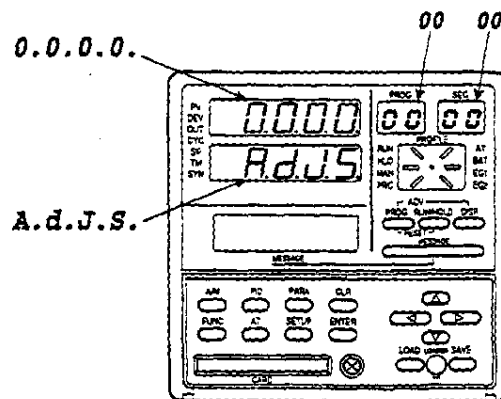

Figure 12-3.

■ **Function test**

Press ↑, ↓, ←, or → **keys** to show (0.0.0.0) on upper display, then press **ENTER** key.

● **Key test (00-01)**

Press **SETUP** key until the **PROG/SEG** display shows (00-01).

When you press each key, the data appears in the upper display (shown in Table 12-3) and in the lower display (shown in Table 12-4).

Table 12-3. Upper Display

Key	Data	Key	Data
ENTER ⏏	0.2.0.0.	PID ⏏	0.4.0.0.
AT ⏏	2.0.0.0.	AM ⏏	0.8.0.0.
FUNC ⏏	1.0.0.0.	PROG ⏏	0.0.0.4.
CLR ⏏	0.0.0.1.	RUNHOLD ⏏	0.0.0.8.
PARA ⏏	0.0.0.2.	MESSAGE ⏏	0.0.2.0.
LOAD ⏏	1.0.0.0.	SAVE ⏏	2.0.0.0.

Table 12-4. Lower Display

Key	Data	Key	Data
← ⏏	0.2.0.0.	△ ⏏	0.1.0.0.
▽ ⏏	0.4.0.0.	⇒ ⏏	0.8.0.0.

! **HANDLING PRECAUTIONS**

1. When you press **DISP** key, calibration mode will be exited.
2. When you press **SETUP** key, the next calibration menu will be entered (Display test).

● Display test (00-02)

Press **SETUP** key until the PROG/SEG display shows (00-02).  
Then, each 7-segment LED, LED indicators and LCD illuminates at every 1 sec.  
This is to check if each LED/LCD illuminates.

● Digital input test (00-03)

Press **SETUP** key until the PROG/SEG display shows (00-03).  
When you turn on or off each remote switch, the upper display will show the data described in Table 12-5.

Table 12-5. DI

Upper Display	D <sub>i</sub> Terminal Number	①	②	③	④	⑬	⑭	⑮	⑯	⑲	⑳	㉑	㉒	㉓	㉔	㉕	㉖	
		↓ ⑫	↓ ⑫	↓ ⑫	↓ ⑫	↓ ⑫	↓ ⑫	↓ ⑫	↓ ⑫	↓ ⑫	↓ ⑫	↓ ⑫	↓ ⑫	↓ ⑫	↓ ⑫	↓ ⑫	↓ ⑫	↓ ⑫
0.0.0.0.		—	—	—	—	—	—	—	—	—	—	—	—	—	—	—	—	—
0.0.0.1.		ON	—	—	—	—	—	—	—	—	—	—	—	—	—	—	—	—
0.0.0.2.		—	ON	—	—	—	—	—	—	—	—	—	—	—	—	—	—	—
0.0.0.4.		—	—	ON	—	—	—	—	—	—	—	—	—	—	—	—	—	—
0.0.0.8.		—	—	—	ON	—	—	—	—	—	—	—	—	—	—	—	—	—
0.0.1.0.		—	—	—	—	ON	—	—	—	—	—	—	—	—	—	—	—	—
0.0.2.0.		—	—	—	—	—	ON	—	—	—	—	—	—	—	—	—	—	—
0.0.4.0.		—	—	—	—	—	—	ON	—	—	—	—	—	—	—	—	—	—
0.0.8.0.		—	—	—	—	—	—	—	ON	—	—	—	—	—	—	—	—	—
0.1.0.0.		—	—	—	—	—	—	—	—	ON	—	—	—	—	—	—	—	—
0.2.0.0.		—	—	—	—	—	—	—	—	—	ON	—	—	—	—	—	—	—
0.4.0.0.		—	—	—	—	—	—	—	—	—	—	ON	—	—	—	—	—	—
0.8.0.0.		—	—	—	—	—	—	—	—	—	—	—	ON	—	—	—	—	—
1.0.0.0.		—	—	—	—	—	—	—	—	—	—	—	—	ON	—	—	—	—
2.0.0.0.		—	—	—	—	—	—	—	—	—	—	—	—	—	ON	—	—	—
4.0.0.0.		—	—	—	—	—	—	—	—	—	—	—	—	—	—	ON	—	—
8.0.0.0.		—	—	—	—	—	—	—	—	—	—	—	—	—	—	—	ON	—

Notes: 1. "ON" means to short the terminals by a jumper.  
2. "—" means to open the terminals.

Example:

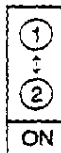

= Short ① and ② terminals.

●Digital output test for control output (00-04)

Press **SETUP** key until the PROG/SEG display shows (00-04).

When the digit of upper display is changed by ↑, ↓, ←, or → keys, the state of 6D or 8D control output is changed as shown in Table 12-6.

Since the 6D hardware is of current output (8D hardware is of open collector) specification, the ON/OFF check must be performed in meeting with the specification.

Table 12-6.

Upper Display	State	Upper Display	State
0.0.0.0.	All OFF	0.0.0.4.	8D output CH1 ON
0.0.0.1.	6D output CH1 ON	0.0.0.8.	8D output CH2 ON
0.0.0.2.	6D output CH2 ON	—	—

●Digital output test for event (00-05)

Press **SETUP** key until the PROG/SEG display shows (00-05).

Table 12-7. DO

Upper Display \ DO Terminal Number	5	6	7	8	17	18	19	20	10	11	22	23	27	28	31	32
	9	9	9	9	9	9	9	9	24	24	24	24	24	24	24	24
0.0.0.0.	—	—	—	—	—	—	—	—	—	—	—	—	—	—	—	—
0.0.0.1.	ON	—	—	—	—	—	—	—	—	—	—	—	—	—	—	—
0.0.0.2.	—	ON	—	—	—	—	—	—	—	—	—	—	—	—	—	—
0.0.0.4.	—	—	ON	—	—	—	—	—	—	—	—	—	—	—	—	—
0.0.0.8.	—	—	—	ON	—	—	—	—	—	—	—	—	—	—	—	—
0.0.1.0.	—	—	—	—	ON	—	—	—	—	—	—	—	—	—	—	—
0.0.2.0.	—	—	—	—	—	ON	—	—	—	—	—	—	—	—	—	—
0.0.4.0.	—	—	—	—	—	—	ON	—	—	—	—	—	—	—	—	—
0.0.8.0.	—	—	—	—	—	—	—	ON	—	—	—	—	—	—	—	—
0.1.0.0.	—	—	—	—	—	—	—	—	ON	—	—	—	—	—	—	—
0.2.0.0.	—	—	—	—	—	—	—	—	—	ON	—	—	—	—	—	—
0.4.0.0.	—	—	—	—	—	—	—	—	—	—	ON	—	—	—	—	—
0.8.0.0.	—	—	—	—	—	—	—	—	—	—	—	ON	—	—	—	—
1.0.0.0.	—	—	—	—	—	—	—	—	—	—	—	—	ON	—	—	—
2.0.0.0.	—	—	—	—	—	—	—	—	—	—	—	—	—	ON	—	—
4.0.0.0.	—	—	—	—	—	—	—	—	—	—	—	—	—	—	ON	—
8.0.0.0.	—	—	—	—	—	—	—	—	—	—	—	—	—	—	—	ON

Notes: 1. "—" in the table means "OFF".

2. Since the DO hardware is of open collector specification, the ON/OFF check must be performed in meeting with the specification.

● Built-in clock adjustment

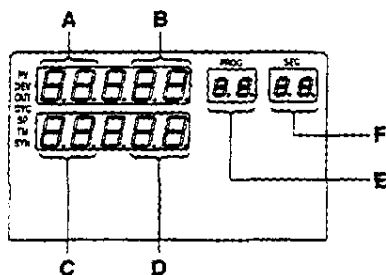

Figure 12-4.

Example:

A: 2 digits of calendar year	1993 .....	.93
B: Month	April .....	.04
C: Day	5th day .....	.05
D: Hour (24 hour system)	3PM .....	.15
E: Minute	6 minutes .....	.06
F: Second	Not changeable	

NOTE

1. ↑, ↓, ←, or → keys are used to change the values, and ENTER key is used to store the values.
2. Clock is still progressing the operation even after the calibration step is moved to this built-in clock adjustment item. After entering the changing mode by ENTER key, the clock stops.
3. After pressing ENTER key, the clock starts from 0 second.
4. Writing to EEPROM is not necessary.

■ PV calibration

Scroll ↑, ↓, ←, or → keys to show (1011) on upper display, then press ENTER key.

● Input CH No. select

Press SETUP key until the PROG/SEG display shows (01-01).

Input the channel No. by ↑, ↓, ←, or → keys (ENTER key not required).

Table 12-8.

CH No.	Upper Display
1	0 0 0 0 0
2	0 0 0 0 1

● Gain No. select

Press SETUP key until the PROG/SEG display shows (01-02). Connect calibration device (See Section "12-3 Set Up").

Input the gain number (See Table 12-9 and Table 12-10) by scrolling ↑, ↓, ←, or → keys the upper display (ENTER key not required).

● PV zero, span

① PV zero adjustment

- (a) Press **SETUP** key until the PROG/SEG display shows (01-03).
- (b) Adjust your calibration device to an output signal equal to the 0% range value (See Table 12-9), the signal need to be on the input for 10 to 15 seconds.
- (c) Press **ENTER** key after display stabilizes.

② PV span adjustment

- (a) Press **SETUP** key until the PROG/SEG display shows (01-04).
- (b) Adjust your calibration device to an output signal equal to the 100% range value (See Table 12-9).
- (c) Press **ENTER** key after display stabilizes.

Table 12-9.

Gain No.	PV Input 0%	PV Input 100%	Connecting Position
0	-5.000mV	10.000mV	Between A(+) and B(-)
1	-10.000mV	18.000mV	Between A(+) and B(-)
2	0.000mV	36.000mV	Between A(+) and B(-)
3	0.000mV	52.000mV	Between A(+) and B(-)
4	0.000mV	100.000mV	Between A(+) and B(-)
5	-1.000V	1.000V	Between A(+) and B(-)
6	0.000V	5.000V	Between A(+) and B(-)
7	0.000V	10.000V	Between A(+) and B(-)
8	4.000mA	20.000mA	Between C(+) and B(-)
9	20Ω	140Ω	Between A(+) and B(-)
10	20Ω	480Ω	Between A(+) and B(-)
11	1Ω	100Ω	Between C(+) and B(-)
12*	0.000V	1.250V	Between C(+) and B(-)

Note: \*, if model isn't Carbon Potential, it isn't necessary to calibrate this item.

● Writing into EEPROM

- Press **SETUP** key until the PROG/SEG display shows (01-05).
- Scroll ↑, ↓, ←, or → keys to show (1.1.1.1.) on the upper display.
- Press **ENTER** key.

Table 12-10.

Group	Type	Code	Gain No.
T/C	K (CA)	K09	3
	K (CA)	K08	2
	K (CA)	K04	1
	E (CRC)	E08	4
	J (IC)	J08	3
	T (CC)	T44	1
	B (PR30-6)	B18	1
	R (PR13)	R16	1
	S (PR10)	S16	1
	W (WRe5-26)	W23	2
	W (WRe5-26)	W14	2
	PR40-20	D19	0
	N	U13	3
	PL II	Y13	3
	Ni-Ni-Mo	Z13	4
	Gold+0.07% Iron-chrome!	Z06	0
K (CA)	K46	0	

Group	Type	Code	Gain No.
RTD	JIS '89 Pt100 (IEC Pt100Ω)	F50	10
		F46	10
		F32	10
		F36	10
		F33	9
		F01	9
		F03	10
		F05	10
		JIS '89 JPt100	P50
	P46		10
	P32		10
	P36		10
	P33		9
	P01		9
	P03		10
	P05		10

Group	Type	Code	Gain No.
Linear mA	4 to 20mA	C01	8
Linear V	0 to 1V	L04	5
	-1 to +1V	L08	5
	1 to 5V	V01	6
	0 to 5V	L05	6
	0 to 10V	L07	7
Linear mA	2.4 to 20mV	Z52	8
Linear mV	0 to 10mV	M01	0
	-10 to +10mV	L02	1
	0 to 100mV	L01	4
O <sub>2</sub> Sensor	0 to 1.25V		12

---

## ■ Cold junction sensor calibration

Scroll  $\uparrow$ ,  $\downarrow$ ,  $\leftarrow$ , or  $\rightarrow$  keys to show (2022) on upper display, then press ENTER key.

### ● The cold junction input 0% (CH1)

- ① Press **SETUP** key until the PROG/SEG display shows (02-01).
- ② Connect the millivolt source between  $\ominus(-)$  and  $\oplus(+)$ , and then input 0.2V (See Figure 12-10).
- ③ Press **ENTER** key after display stabilizes, AD count is shown on lower display.

### ● The cold junction input 100% (CH1)

- ① Press **SETUP** key until the PROG/SEG display shows (02-02).
- ② Connect the millivolt source between  $\ominus(-)$  and  $\oplus(+)$ , and then input 1.0V (See Figure 12-10).
- ③ Press **ENTER** key after display stabilizes, AD count is shown on lower display.

### ● The cold junction AD count data (CH1)

- ① Press **SETUP** key until the PROG/SEG display shows (02-03).
- ② Press **ENTER** key after display stabilizes, AD count is shown on lower display.

### ● The cold junction temperature data (CH1)

- ① Press **SETUP** key until the PROG/SEG display shows (02-04).
- ② Connect the thermometer  $\ominus$ .
- ③ Scroll  $\uparrow$ ,  $\downarrow$ ,  $\leftarrow$ , or  $\rightarrow$  keys to set above temperature value.
- ④ Press **ENTER** key.

### ● The cold junction input 0% (CH2)

- ① Press **SETUP** key until the PROG/SEG display shows (02-05).
- ② Connect the millivolt source between  $\ominus(-)$  and  $\oplus(+)$ , and then input 0.2V (See Figure 12-10).
- ③ Press **ENTER** key after display stabilizes, AD count is shown on lower display.

### ● The cold junction input 100% (CH2)

- ① Press **SETUP** key until the PROG/SEG display shows (02-06).
- ② Connect the millivolt source between  $\ominus(-)$  and  $\oplus(+)$ , and then input 1.0V (See Figure 12-10).
- ③ Press **ENTER** key after display stabilizes, AD count is shown on lower display.

### ● The cold junction AD count data (CH2)

- ① Press **SETUP** key until the PROG/SEG display shows (02-07).
- ② Press **ENTER** key after display stabilizes, AD count is shown on lower display.

### ● The cold junction temperature data (CH2)

- ① Press **SETUP** key until the PROG/SEG display shows (02-08).
- ② Connect the thermometer  $\ominus$ .
- ③ Scroll  $\uparrow$ ,  $\downarrow$ ,  $\leftarrow$ , or  $\rightarrow$  keys to set above temperature value.
- ④ Press **ENTER** key.

### ● Writing into EEPROM

- ① Press **SETUP** key until the PROG/SEG display shows (02-09).
- ② Scroll  $\uparrow$ ,  $\downarrow$ ,  $\leftarrow$ , or  $\rightarrow$  keys to show (1.1.1.1.) on upper display.
- ③ Press **ENTER** key.

---

## ■ Current output calibration

Scroll **↑**, **↓**, **←**, or **→** **keys** to show (**6.0.6.6.**) on the upper display, then press **ENTER** key.

Connect the digital ammeter across terminals (See Figure 12-9).

### ● OUT CH1 output calibration

① Press **SETUP** key until the PROG/SEG display shows (**06-01**).

Scroll **↑**, **↓**, **←**, or **→** **keys** until meter indicates 4.00mA, then press **ENTER** key.

② Press **SETUP** key until the PROG/SEG display shows (**06-02**).

Scroll **↑**, **↓**, **←**, or **→** **keys** until meter indicates 20.00mA, then press **ENTER** key.

### ● OUT CH2 output calibration

① Press **SETUP** key until the PROG/SEG display shows (**06-03**).

Scroll **↑**, **↓**, **←**, or **→** **keys** until meter indicates 4.00mA, then press **ENTER** key.

② Press **SETUP** key until the PROG/SEG display shows (**06-04**).

Scroll **↑**, **↓**, **←**, or **→** **keys** until meter indicates 20.00mA, then press **ENTER** key.

### ● AUX CH1 output calibration

① Press **SETUP** key until the PROG/SEG display shows (**06-05**).

Scroll **↑**, **↓**, **←**, or **→** **keys** until meter indicates 4.00mA, then press **ENTER** key.

② Press **SETUP** key until the PROG/SEG display shows (**06-06**).

Scroll **↑**, **↓**, **←**, or **→** **keys** until meter indicates 20.00mA, then press **ENTER** key.

### ● AUX CH2 output calibration

① Press **SETUP** key until the PROG/SEG display shows (**06-07**).

Scroll **↑**, **↓**, **←**, or **→** **keys** until meter indicates 4.00mA, then press **ENTER** key.

② Press **SETUP** key until the PROG/SEG display shows (**06-08**).

Scroll **↑**, **↓**, **←**, or **→** **keys** until meter indicates 20.00mA, then press **ENTER** key.

● Writing into EEPROM

- ① Press **SETUP** key until the PROG/SEG display shows (06-09).  
Scroll ↑, ↓, ←, or → keys to show (1.1.1.1.) on upper display.
- ② Press **ENTER** key.

## 12-3 Set Up

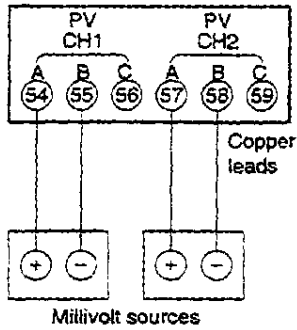

Figure 12-5. Thermocouple Inputs

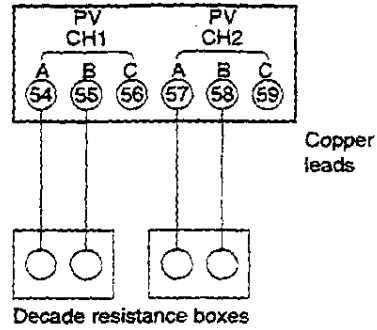

Figure 12-6. RTD Inputs

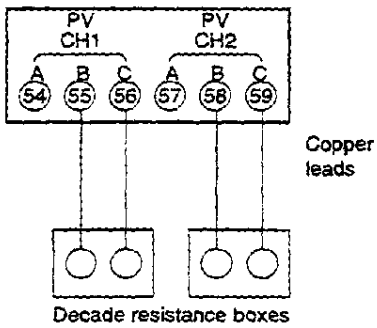

Figure 12-7. RTD Inputs

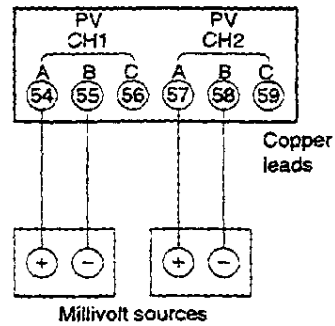

Figure 12-8. mV, V, Inputs

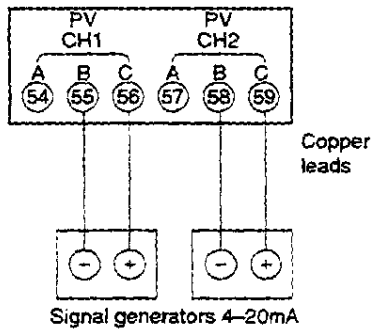

Figure 12-9. mA Inputs

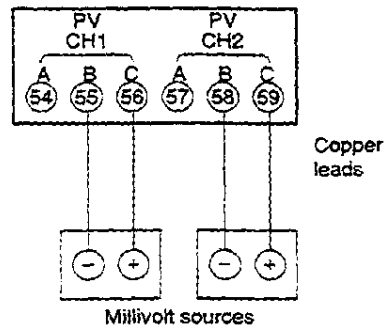

Figure 12-10. CJ, O<sub>2</sub> Sensor

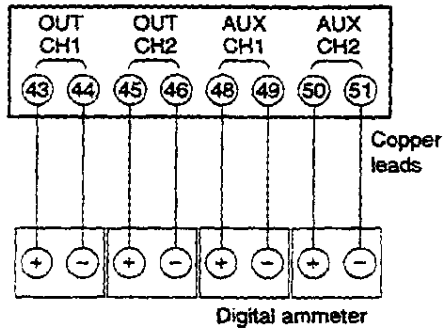

Figure 12-11. Current Outputs