

## 4-6 PV Input (Analog Input) Connection

### CAUTION



Current applied to current input terminals 55, 56 and 58, 59 must meet the specified range.  
Failure to heed this caution may lead to fire or equipment breakdown.

#### ■ PV input CH1 connection

PV input CH1 is a multi-input type input for sensors. Connect as shown below, according to the type of sensor being used.

##### • Thermocouple input

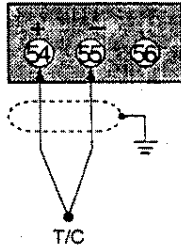

##### • Resistance temperature detector input

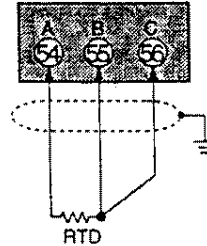

##### • DC voltage input

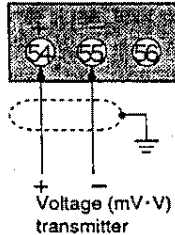

##### • DC current input

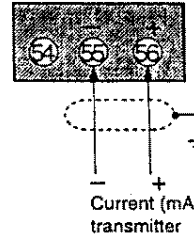

#### ■ PV input CH2 connection

PV input CH2 is a multi-input type input for sensors. Connect as shown below, according to the type of sensor being used.

##### • Thermocouple input

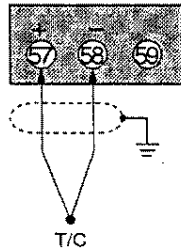

##### • Resistance temperature detector input

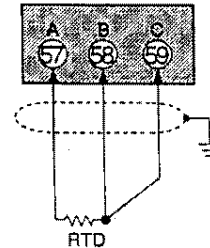

##### • DC voltage input

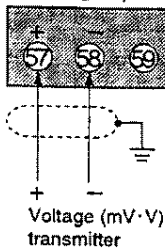

##### • DC current input

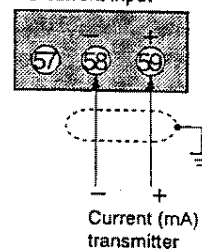

## 4-7 Control Output Connection



### WARNING



Be sure to turn off the power supply when you are installing or removing the controller. Failure to heed this warning may lead to electric shock.

#### ■ Current output

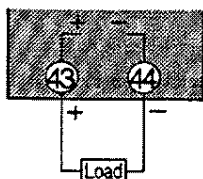

4 to 20mA DC  
Load resistance less than 600Ω

#### ■ Voltage output

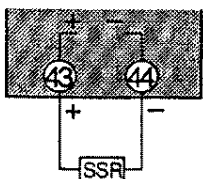

2 to 22mA DC  
With current value adjustment function  
(Setup data C92)

#### ! HANDLING PRECAUTIONS

The voltage output is a constant current circuit inside. The SSR used is set to an optimum voltage to meet the requirements of the load. Enter the value in the setup data. A normal SSR voltage has been set at the factory before shipment.

#### ■ Open collector output

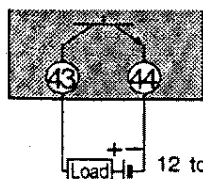

Max. load current : 100mA  
Leakage current when off : less than 0.1mA

12 to 24V DC

#### ! HANDLING PRECAUTIONS

- Do not short-circuit the positive (+) terminal of the external power supply to terminal 43 on the DCP551. Doing so causes the open collector outputs to malfunction. (There is no short circuit preventing circuit inside.)
- When connecting a semiconductor load such as a programmable controller (sequencer), select a module in which the current directions match. Use one made inoperative by the leakage current produced when the digital outputs are shut off.

## 4-8 Auxiliary Output (Output CH1, CH2) Connection

### ⚠ WARNING



Be sure to turn off the power supply when you connect the controller.  
Failure to do so may lead to electric shock or fire.

#### ■ Auxiliary output CH1 connection

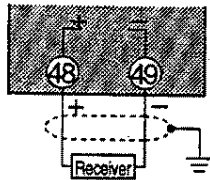

4 to 20mA DC  
Load resistance less than 600Ω

#### ■ Auxiliary output CH2 connection

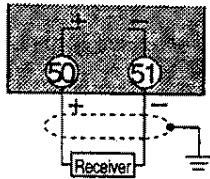

4 to 20mA DC  
Load resistance less than 600Ω

## 4-9 Event Output (Open Collector Output) Connection

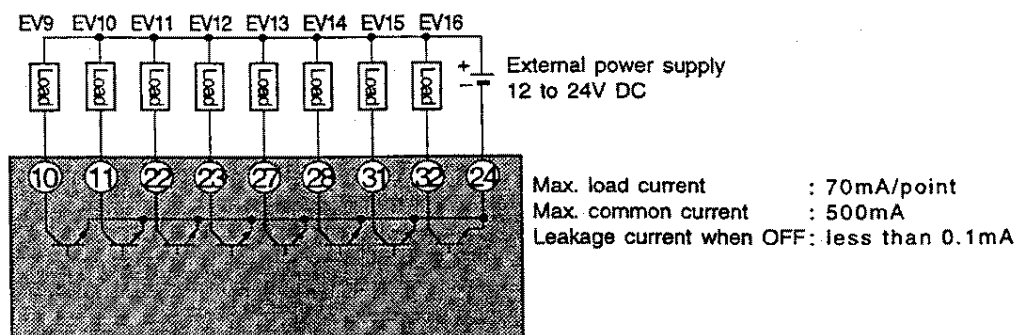
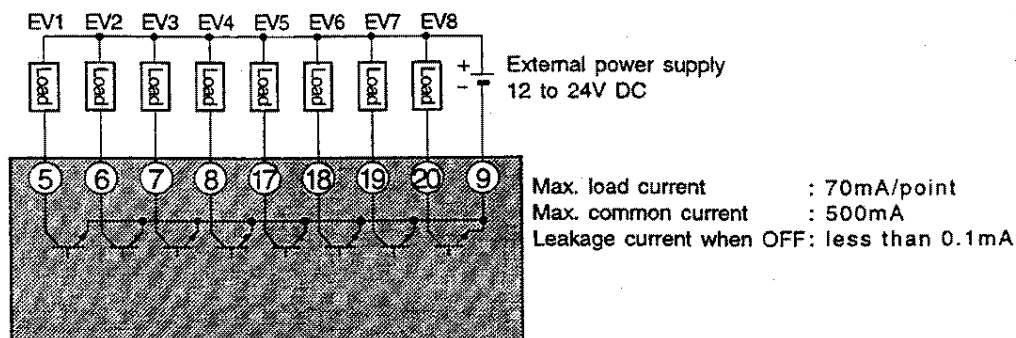

### ! HANDLING PRECAUTIONS

- Do not short-circuit the positive (+) terminal of the external power supply to terminals ⑤ to ⑧, ⑰ to ⑳, ⑩, ⑪, ⑫, ⑬, ⑭, ⑮, ⑯, and ㉔ on the DCP551. Doing so causes the open collector outputs to malfunction. (There is no short circuit preventing circuit inside.)
- When connecting a semiconductor load such as a programmable controller (sequencer), select a module in which the current directions match. Use one made inoperative by the leakage current produced when the digital outputs are shut off.

## 4-10 External Switch Input Connection

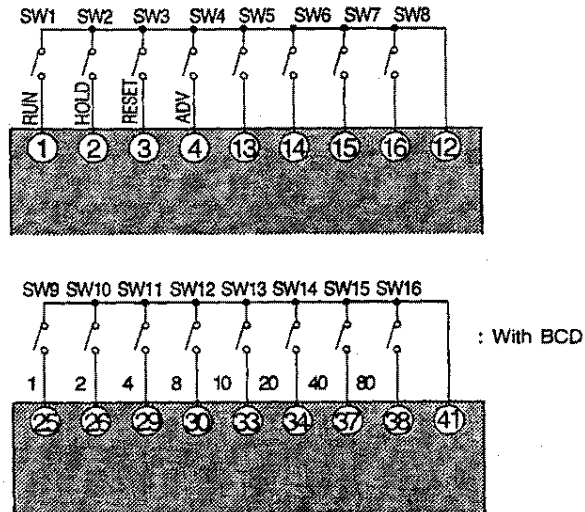

### ● Internal circuit diagram of the DCP551 connecting external switch input

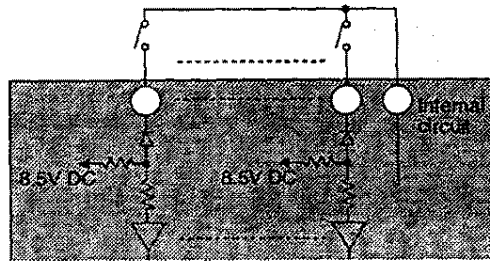

### ! HANDLING PRECAUTIONS

- The inputs of the DCP551 unit are provided with a built-in power supply (open voltage type, 8.5V DC). Always use no-voltage contacts externally.
- For the no-voltage contacts, use gold contacts or other relays that switch on small currents. Other types of relay contacts may not switch. Use contacts that have ample margin over the minimum switching capacity with respect to the current and open voltage ratings of contacts provided on the DCP551.
- If using semiconductors (open collectors, etc.) as no-voltage contacts, use one that maintains a potential of no more than 2V across the contacts when actuated, and a leakage current of no more than 0.1mA when shut off.
- Common terminals ⑫ and ④① of the external switch input are connected internally.

## 4-11 Communication Connection

### ■ RS-485 connection

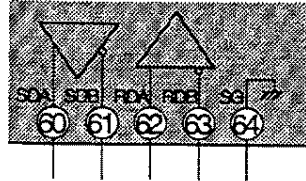

#### ! HANDLING PRECAUTIONS

- The slave station can be connected in a multi-drop configuration.
- Always set a unique address to each slave station.
- Attach terminating resistances (a total of four when connecting a 5-wire system) to the ends of the communications lines. Use 1/2W or greater terminating resistances of  $150\Omega \pm 5\%$ .
- If connecting three lines, short-circuit terminals 60, 62 and 61, 63.
- Do not short-circuit the RDA to RDB and SDA to SDB terminals. Doing so may cause the DCP551 to malfunction.

■ Connection to ST221

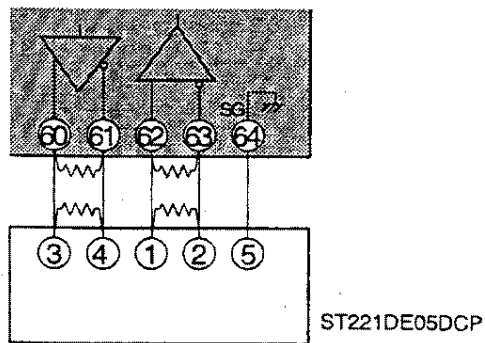

⚠ HANDLING PRECAUTIONS

- Attach 1/2W or greater terminating resistances of  $150\Omega \pm 5\%$  at each end of the communications lines.
- The DCP551 operates as a master station when connected to an ST221 during communications.