

## 2.5 Wiring Diagrams, Continued

### Input #1/Input #2 connections

Figure 2-6 shows the wiring connections for Input #1 and Input #2.

Figure 2-6 Input #1/Input #2 Connections

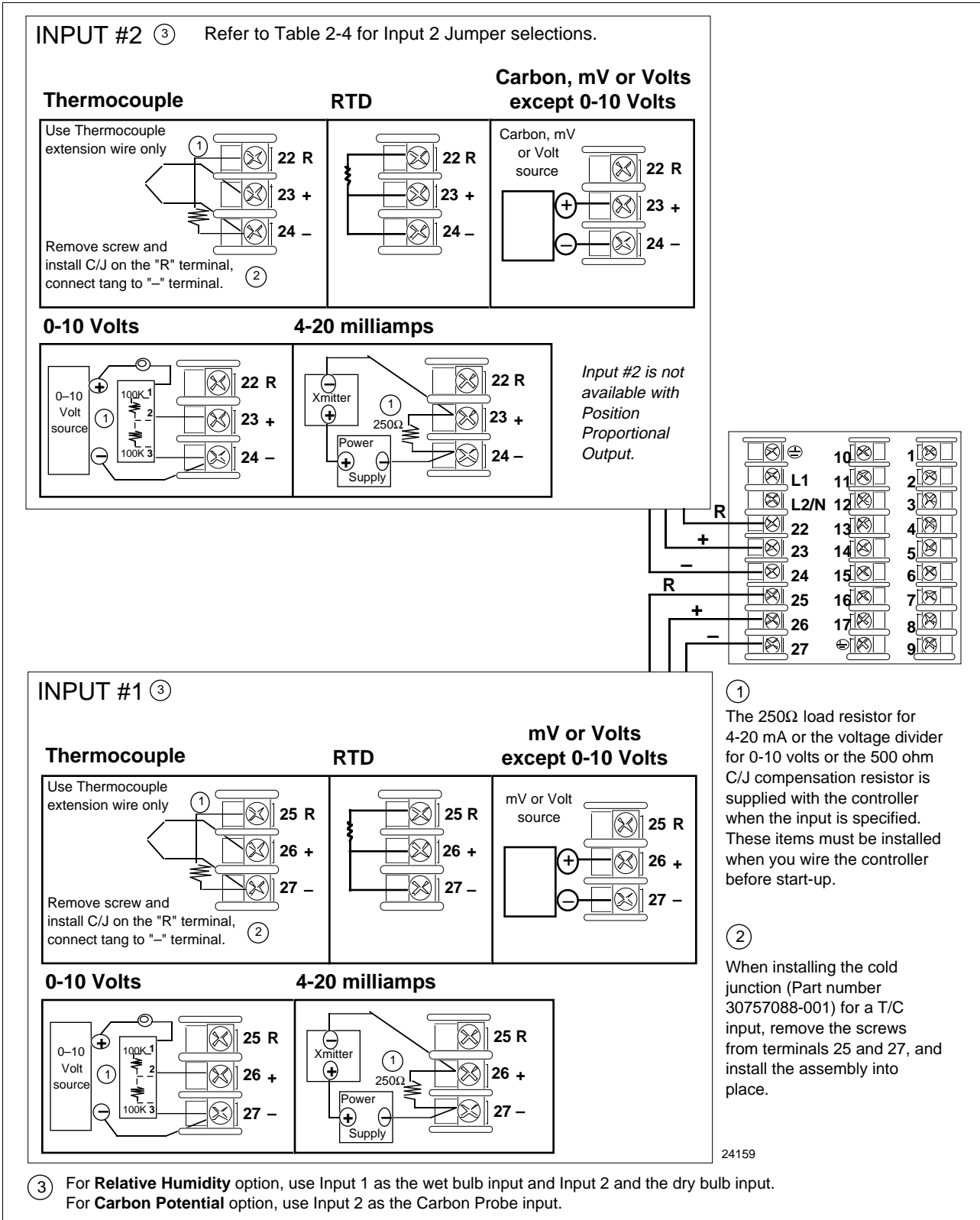

## 2.5 Wiring Diagrams, Continued

### Two HLAI replace second LLAI connections

Figure 2-7 shows the wiring connections for replacing the second LLAI with two HLAI.

Figure 2-7 Two HLAI Replace 2nd LLAI Connections (Future)

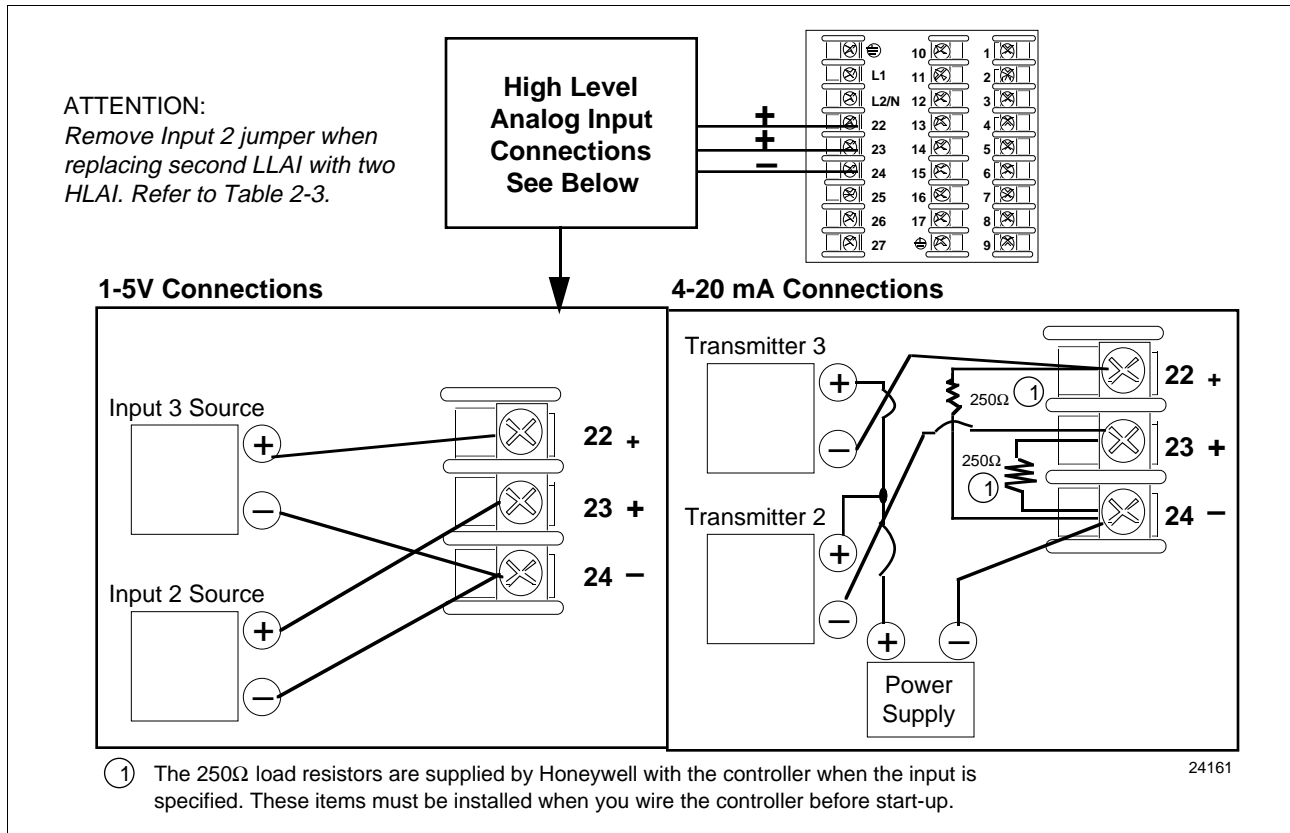

### Input 2 jumper

Table 2-4 shows the location of the second input jumper and the input types available for each jumper position.

Table 2-4 Input 2 Jumper Selections

<b>Jumper Location</b>	<p>24162</p>		
<b>Jumper Position</b>	W1	W2	None (remove jumper)
<b>Input Types Available</b>	Slidewire, 4-20 mA, 0-20 mA, 1-5V, 0-5V	Thermocouple, RTD, mV, Radiamatic, Carbon, Oxygen	Two HLAI replace LLAI

Continued on next page