

## 2.5 Wiring Diagrams, Continued

### Time proportional output

There are three types of Time Proportional outputs available on the UDC 3300.

- Electromechanical Relay Output (**Model DC330X-EE-XXX**)—Figure 2-8
- Solid State Relay Output (**Model DC330X-AA(SS)-XXX**)—Figures 2-9
- Open Collector Output (**Model DC330X-TT-XXX**)—Figure 2-11

The Alarm wiring connections are the same for all three outputs.

For Control and Alarm Relay Contact information, see Tables 2-7 and 2-8.

Figure 2-8 shows the Output and Alarm wiring connections for models with Electromechanical Relay Output.

Figure 2-8 **Electromechanical Relay Output—Model DC330X-EE-XXX**

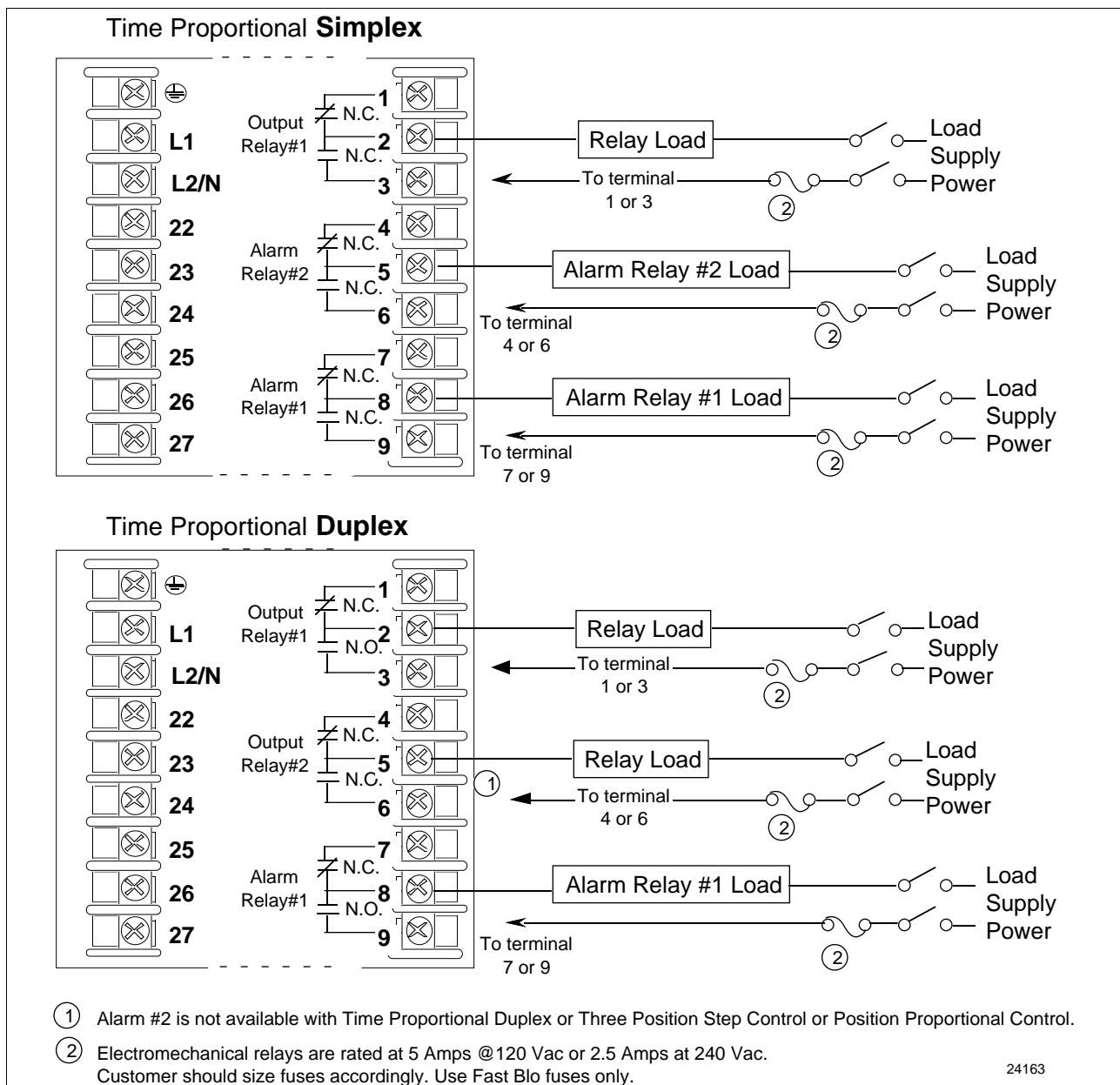

Continued on next page

## 2.5 Wiring Diagrams, Continued

### Time proportional output, continued

Figure 2-9 shows the Output and Alarm wiring connections for models with Solid State Relay Output (**Model DC330X-AA-XX or DC330X-SS-XX**).

For Control and Alarm Relay Contact information, see Tables 2-7 and 2-8.

Figure 2-9 **Solid State Relay Output**—Model DC330X-AA-XX or DC330X-SS-XX

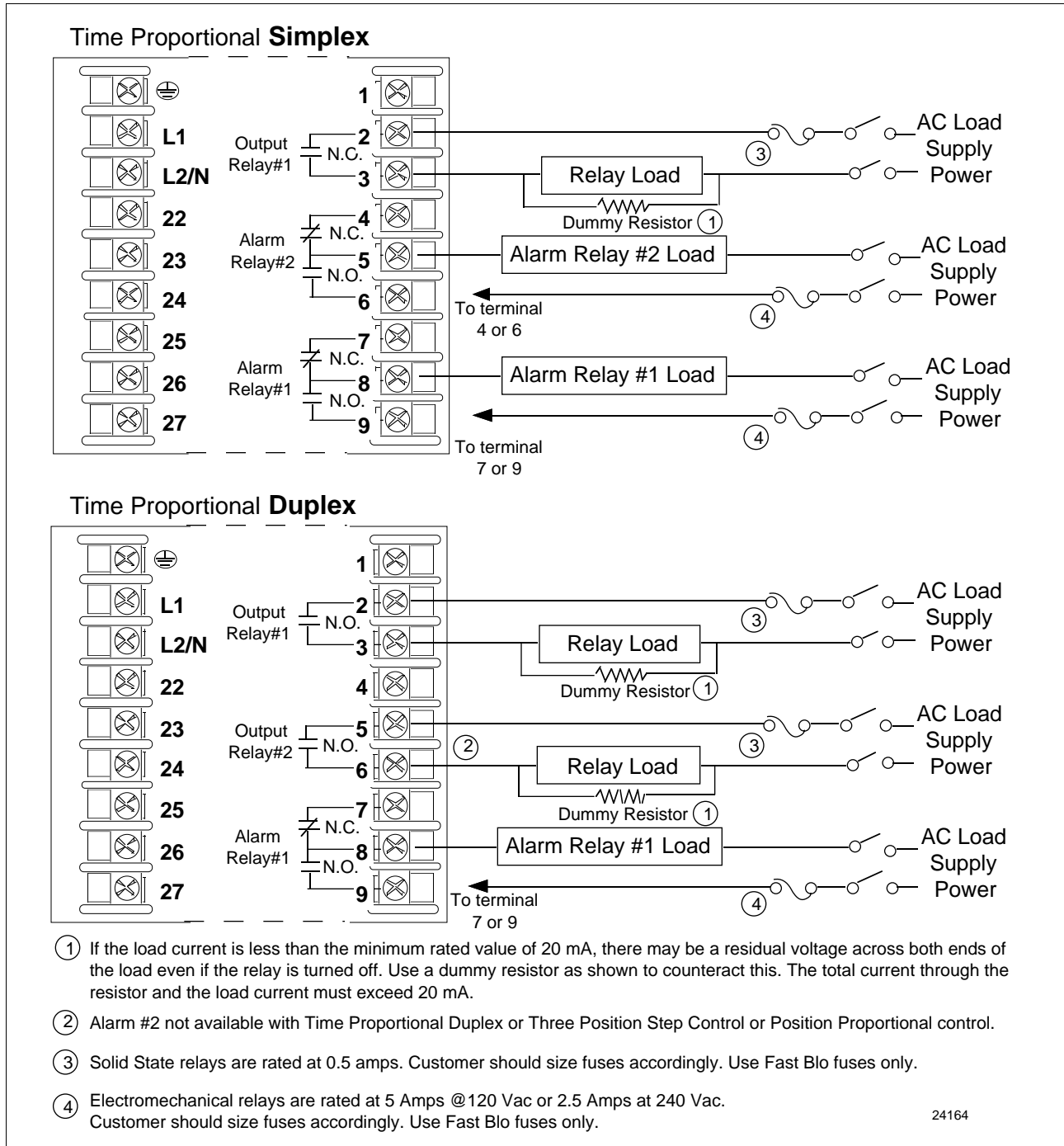

Continued on next page

## 2.5 Wiring Diagrams, Continued

Time proportional  
output, continued

Figure 2-10 shows the wiring connections for the external 10-amp Solid State Relay output (**Model DC330X-SS-XX**).

Figure 2-10 **10-amp Solid State Relay Output**—Model DC330X-SS-XX

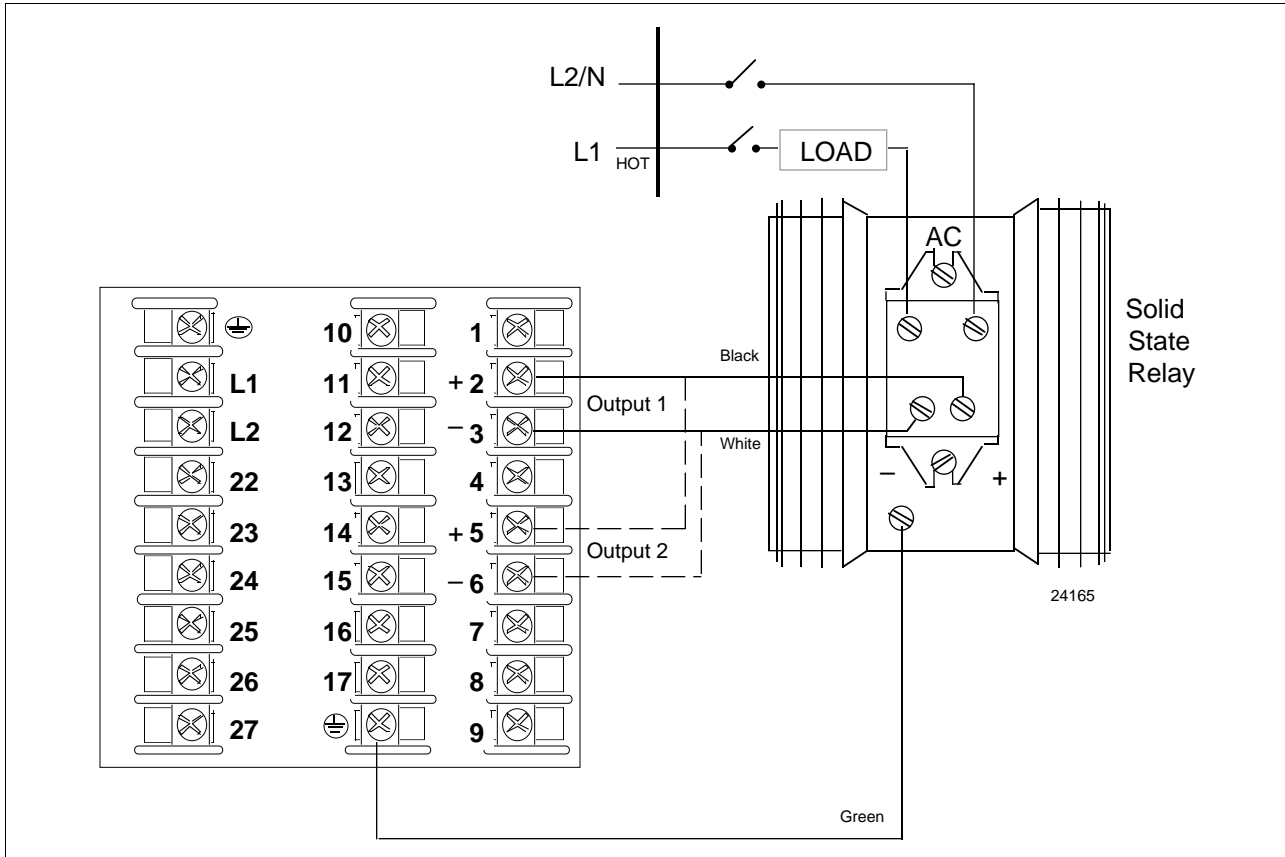

*Continued on next page*

## 2.5 Wiring Diagrams, Continued

### Time proportional output, continued

Figure 2-11 shows the Output and Alarm wiring connections for models with Open Collector Output (**DC330X-TT-XXX**)

For Control and Alarm Relay Contact information, see Tables 2-7 and 2-8.

Figure 2-11 **Open Collector Output**—Model DC330X-TT-XXX

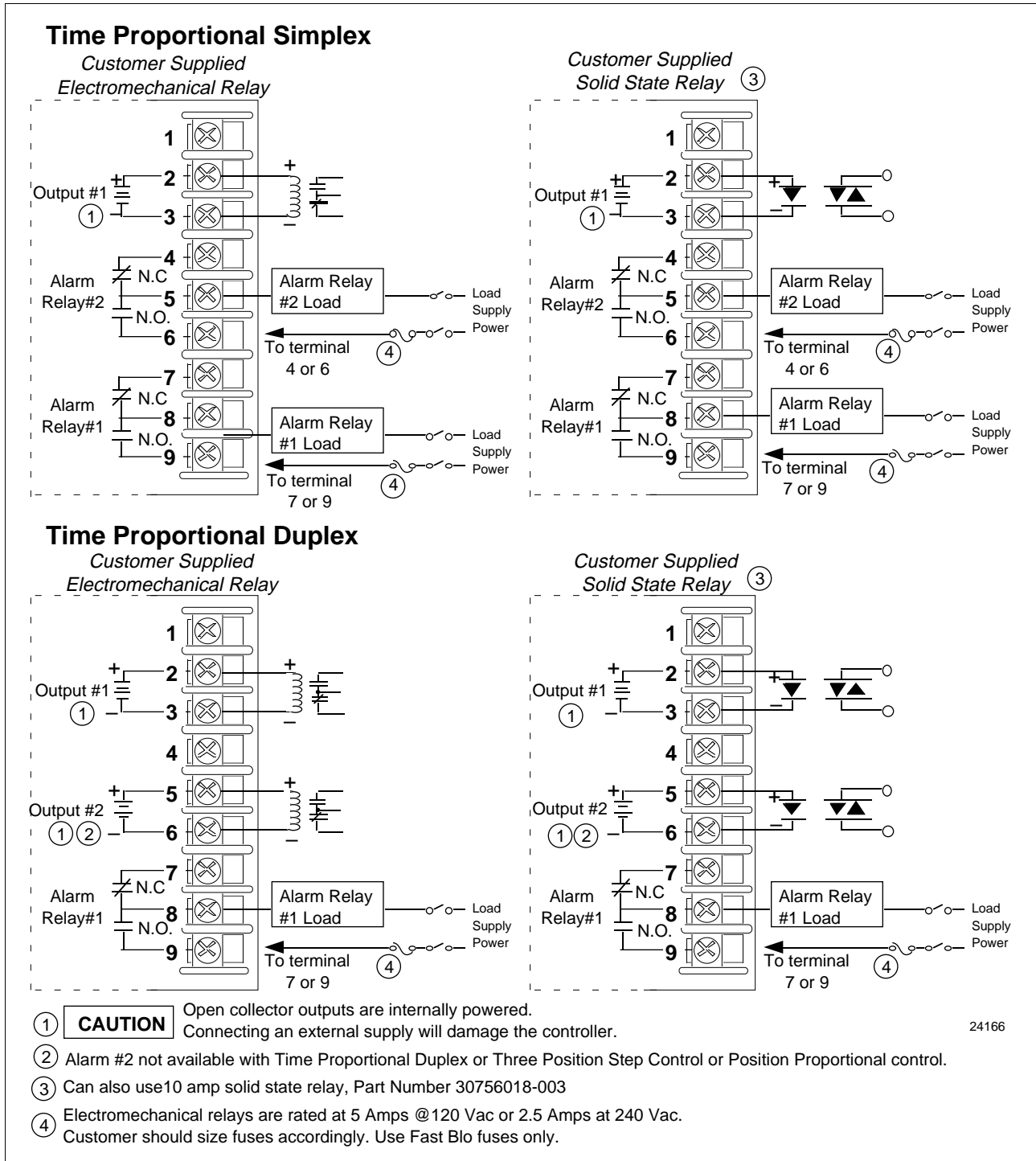

Continued on next page

## 2.5 Wiring Diagrams, Continued

### Current output/ universal output connections

Figure 2-12 shows the Output and Alarm wiring connections for models with Current Output (**Model DC330X-KE-XXX**). See Table 2-5 for wiring restrictions.

For Control and Alarm Relay Contact information, see Tables 2-7 and 2-8.

Figure 2-12 Current Output Current /Time Duplex, Time/Current Duplex, Position Proportional, or Three Position Step Control

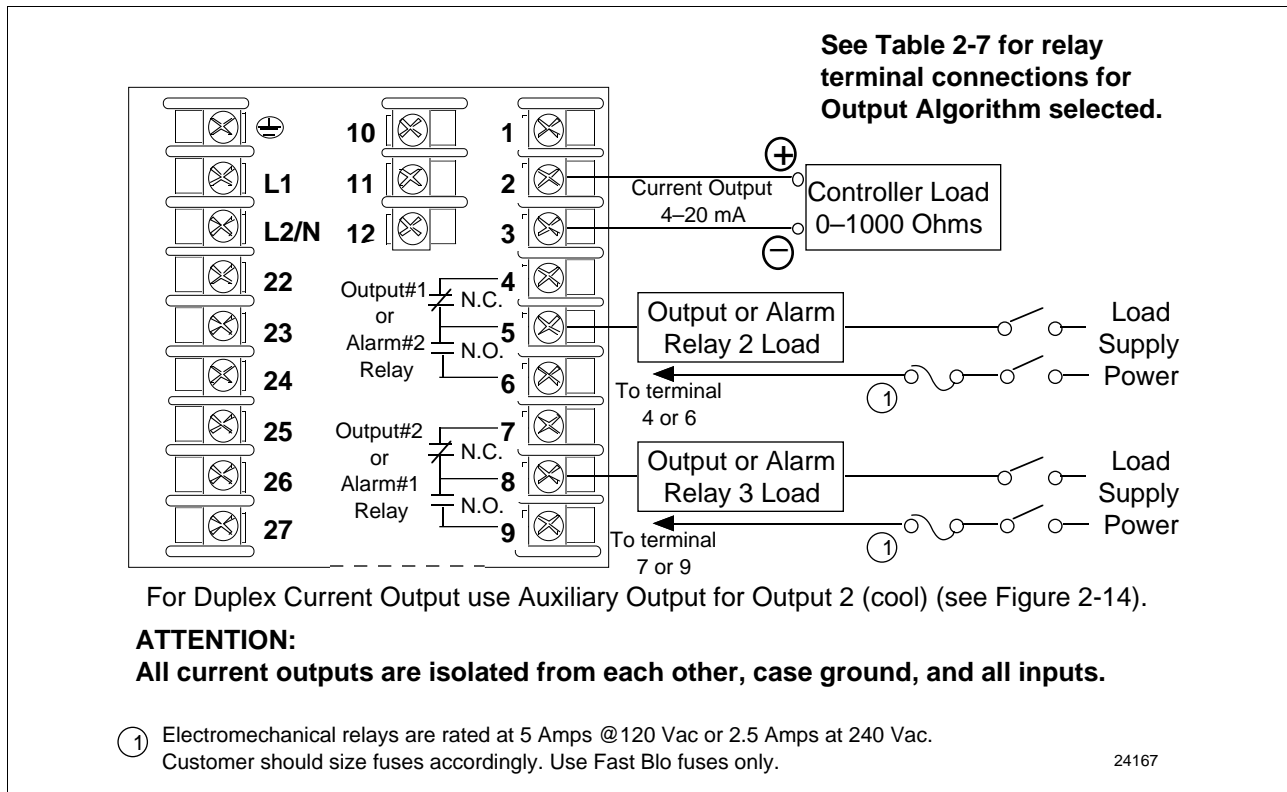

Table 2-5 Universal Output Wiring Functionality and Restrictions for Figure 2-12

<b>Controller with Two Current Outputs and Two Relay Outputs</b> SINGLE LOOP OR CASCADE CONTROL OUTPUT					
Output Type	Current	Auxiliary	Relay #1	Relay #2	Relay #3
<b>Time Simplex</b>	Not used	Not used	N/A	Output 1	Alarm 1
<b>Current</b>	Output 1	Not used	N/A	Alarm 2	Alarm 1
<b>Position</b> (not available on Cascade Control)	Not used	Not used	N/A	Output 1	Output 2
<b>Time Duplex or TPSC</b>	Not used	Not used	N/A	Output 1	Output 2
<b>Current Duplex 100%</b>	Output 1	Not used	N/A	Alarm 2	Alarm 1
<b>Current Duplex 50%</b>	Output 1	Output 2	N/A	Alarm 2	Alarm 1
<b>Current/Time or Time/Current</b>	Output 1 or 2	Not used	N/A	Output 1 or 2	Alarm 1

Continued on next page

## 2.5 Wiring Diagrams, Continued

### Current output/ universal output connections, continued

Figure 2-13 shows the Output and Alarm wiring connections for models with a Current Output (Auxiliary Output) and three Relay Outputs (**Model DC330X-EE-2XX**). See Table 2-6 for wiring restrictions.

For Control and Alarm Relay Contact information, see Tables 2-7 and 2-8.

Figure 2-13 Auxiliary Output and Three Relay Outputs

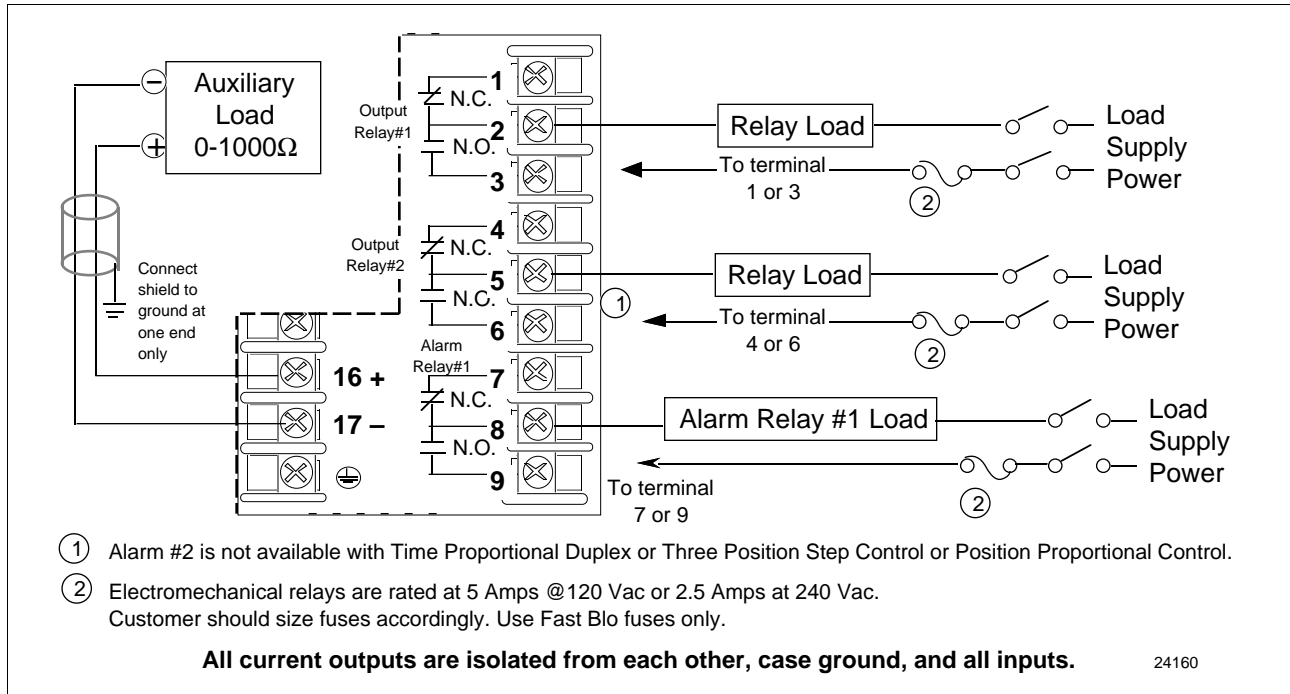

Table 2-6 Universal Output Wiring Functionality and Restrictions for Figure 2-13

Controller with One Current Output (Auxiliary Output) and Three Relay Outputs SINGLE LOOP OR CASCADE CONTROL OUTPUT					
Output Type	Current	Auxiliary	Relay #1	Relay #2	Relay #3
Time Simplex	N/A	Not used	Output 1	Alarm 2	Alarm 1
Current	N/A	Output 1	Not used	Alarm 2	Alarm 1
Position (not available on Cascade Control)	N/A	Not used	Output 1	Output 2	Alarm 1
Time Duplex or TPSC	N/A	Not used	Output 1	Output 2	Alarm 1
Current Duplex 100%	N/A	Output	N/A	Alarm 2	Alarm 1
Current Duplex 50% (N/A)	N/A	N/A	N/A	N/A	N/A
Current/Time or Time/Current	N/A	Output 1 or 2	Output 1 or 2	Alarm 2	Alarm 1

Continued on next page

## 2.5 Wiring Diagrams, Continued

### Position proportional output connections

Figure 2-14 shows the Output and Alarm wiring connections for models with Position Proportional Output or Three Position Step Control (**Models DC330X-EE-XXX-X2, DC330X-AA-XXX-X2**).

For Control and Alarm Relay Contact information, see Tables 2-7 and 2-8.

### Calibration

Position Proportional Output or *Three Position Step* models must have the output calibrated after installation (see *Section 8—Position Proportional Output Calibration*) to ensure that the displayed output (slidewire position) agrees with the actual final control element position.

Three Position Step models only require that the motor time be entered. Full calibration is not required.

Figure 2-14 Position Proportional Output or Three Position Step—Models DC330X-EE-XXX-X2, DC330X-AA-XXX-X2

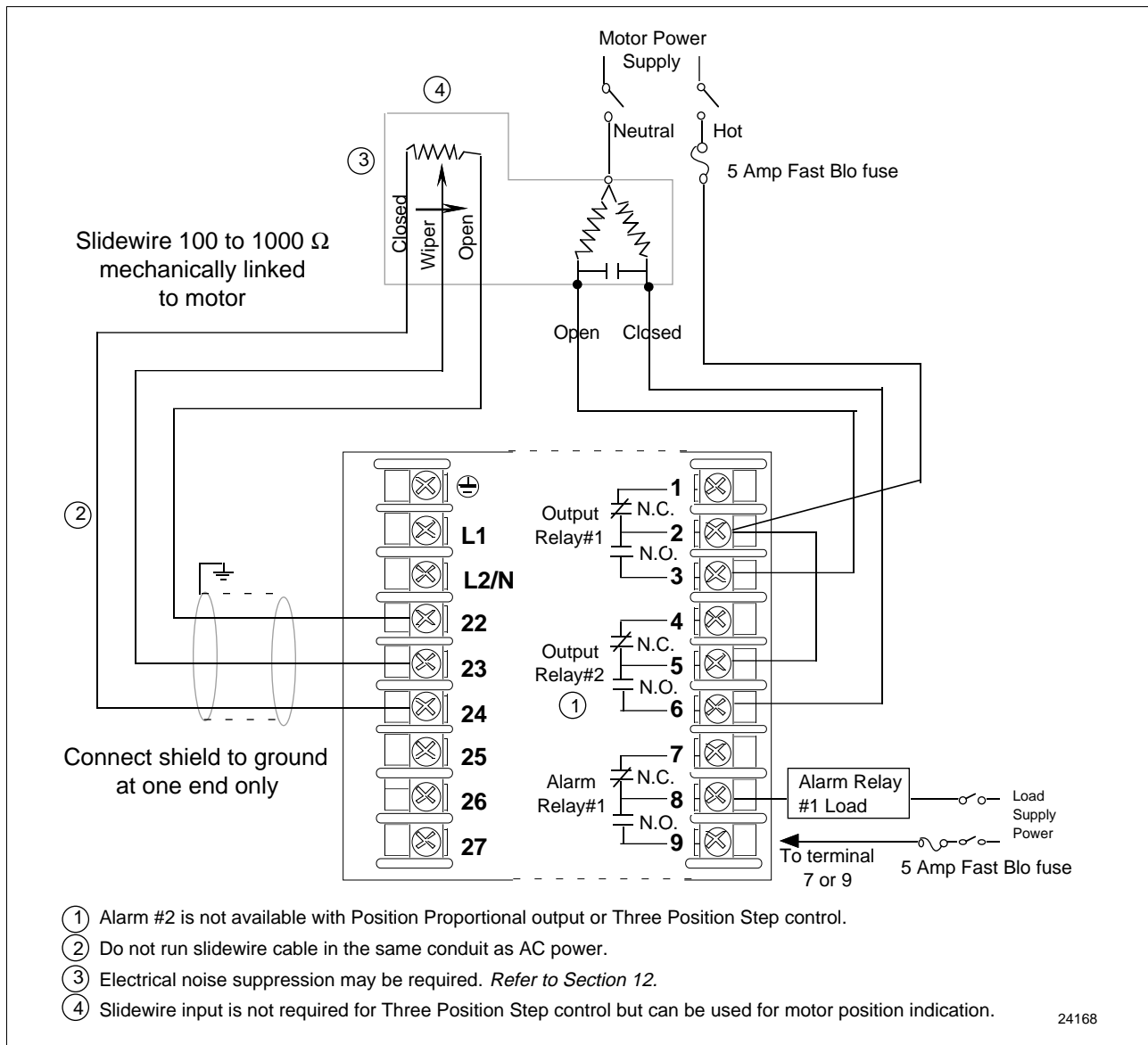

Continued on next page