

2.5 Wiring Diagrams, Continued

Communications option connections

There are two types of Communications option available:

- RS422/485/MODBUS (Model DC330X-XX-1XX or DC330X-XX-5XX)—Figure 2-17 (also refer to Document #51-51-25-35)
- DMCS (Model DC330X-XX-4XX)—Figure 2-18 (also refer to Document #82-50-10-23)

Figure 2-17 RS422/485/MODBUS Communications Option Connections

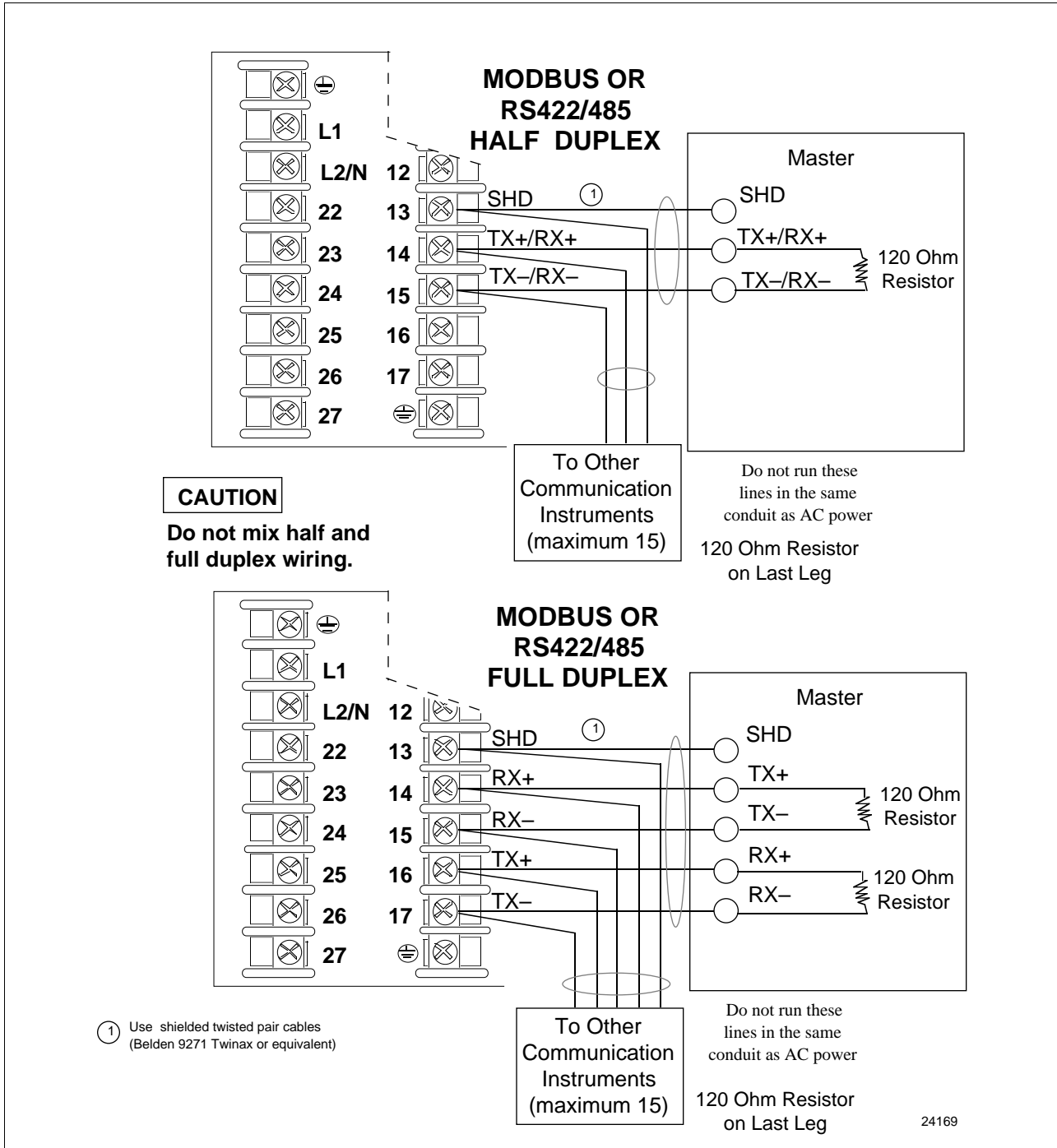

Continued on next page

2.5 Wiring Diagrams, Continued

Communications option connections, continued

Figure 2-18 shows the wiring connections for the DMCS Communications option (Model DC330X-XX-4XX).

Figure 2-18 DMCS Communications Option Connections

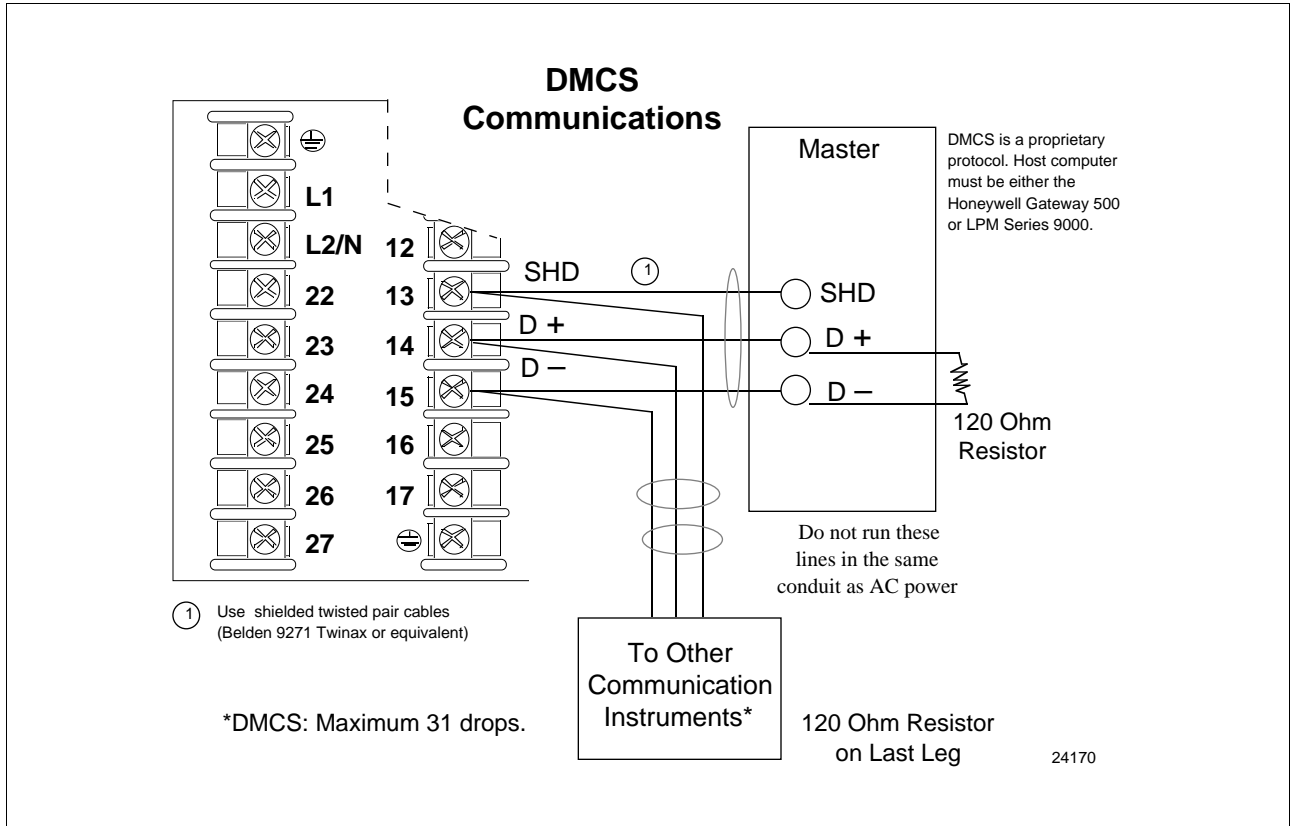

Continued on next page