

How to Start up and Run Self Test on Models DR4301 and DR4302, Recorders Without Display

Overview

Introduction

This subsection provides procedures and reference information for operating the recorder models that do not have a display. It assumes that the recorder has been properly mounted and wired in accordance with the instructions in Section 2, and prepared as described earlier in this section.



WARNING—SHOCK HAZARD



SET THE SWITCHES DESCRIBED IN THIS SECTION WITH THE UNIT POWER DISCONNECTED. BE SURE TO AVOID TOUCHING POWER CONNECTIONS AT TB1. FAILURE TO OBSERVE THIS PRECAUTION CAN RESULT IN EXPOSURE TO A POTENTIALLY LETHAL SHOCK HAZARD. MORE THAN ONE SWITCH MAY BE REQUIRED TO DE-ENERGIZE UNIT.

Preparing the Recorder for Operation

Introduction

Before applying power to the recorder, complete these preparation tasks.

CAUTION

Never move the pen arms when the unit is operating unless adjusting the pen alignment as described in Section 7.



WARNING

When the unit is powered, a potentially lethal shock hazard exists at the AC power connections at TB1 on the printed circuit assemblies for the pens (behind the chart plate).

Procedure

Refer to Figure 3-3 to identify the basic chart plate components and follow the procedure in Table 3-4 to prepare the recorder for operation.

Table 3-4 Preparing the Recorder for Operation

Step	Action
1	Open the door.
2	Pull up on the pen lifter to raise the pen(s) from the chart plate and remove the protective cap from each pen tip.
3	Slip the new chart under the pen lifter, pen and time index, and press it into place over the chart hub and locating pin.
4	Grasp the locating pin, and turn the chart until the desired time line on the chart is aligned with the time index on the chart plate and pen 1. Push down the lifter to return the pen(s) to the chart.

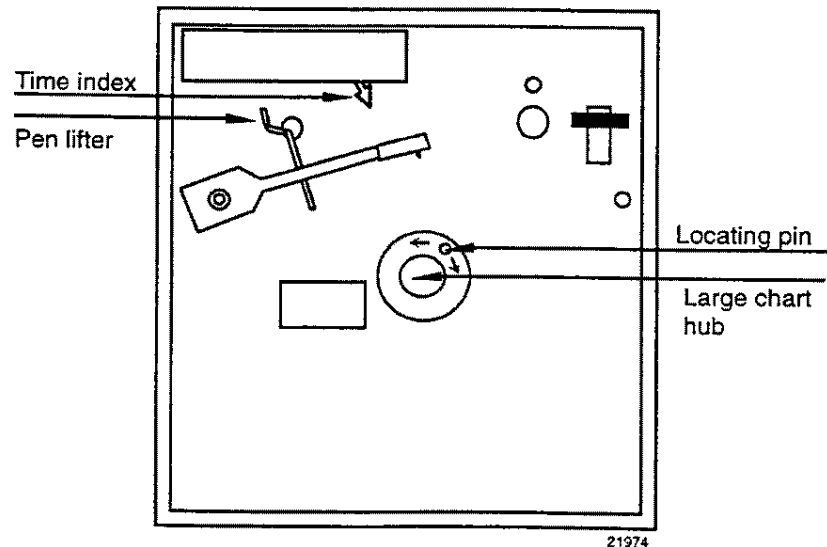

Figure 3-3 Basic Chart Plate Components

Running the Optional Step Test

Introduction

You can test the recorder's mechanical operation by running a "step test". This test is initiated by setting switches as described in Table 3-5.

This test prints a step pattern, which is independent of any chart settings, with horizontal lines drawn by both pens at each 10% increment on the chart (see Figure 3-4).

The test will run for one complete revolution of the chart before it returns to normal operation. The chart revolution for the test takes approximately three minutes, regardless of configured chart speed.



WARNING

When the unit is powered, a potentially lethal shock hazard exists at the AC power connections at TB1 on the printed circuit assemblies for the pens (behind the chart plate).

Procedure

Use the procedure in Table 3-5 to run the step test.

Table 3-5 Procedure for Running the Step Test



Step	Action/Result	Graphic
1	Turn off the power to the recorder.	
2	Make sure the cap is removed from the tip of each pen and the chart is installed.	
3	Loosen captive screw and swing out the chart plate.	
4	Note the position of all eight switches on SW1 on the printed circuit assembly (PCA) for each pen.	See Figure 3-1.
5	Set switches 1 and 2 in SW1 in the OFF position on each pen's PCA. All other SW1 switches should be ON (toward the edge of the board). This is configuration #252 in Table 3-3.	
6	Place run switch SW5 to the setup position (toward the top of the board) on each pen's PCA.	
7	Apply power to the recorder.	
8	The recorder will begin the test. The duration of the test is approximately 3 minutes. (When the test has been completed the pens will move away from the test position, but the recorder cannot return to normal operation until the switches are returned to their correct non-test settings.)	
9	At the conclusion of the test turn off the power to the recorder.	

Table 3-5 continued on next page.

Table 3-5 Procedure for Running the Step Test, Continued

Step	Action/Result	Graphic
10	Place run switch SW5 to the run position (toward the bottom of the board) on each PCA.	
11	Set configuration switches on the PCA for each pen back to the settings noted in Step 4.	
12	Secure the chart plate in the operational position.	
13	To resume normal operation leave SW5 in the run position and power up the recorder.	

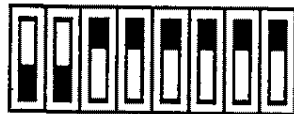
Chart step pattern

Figure 3-4 is a typical chart step pattern generated by the recorder in the step test.

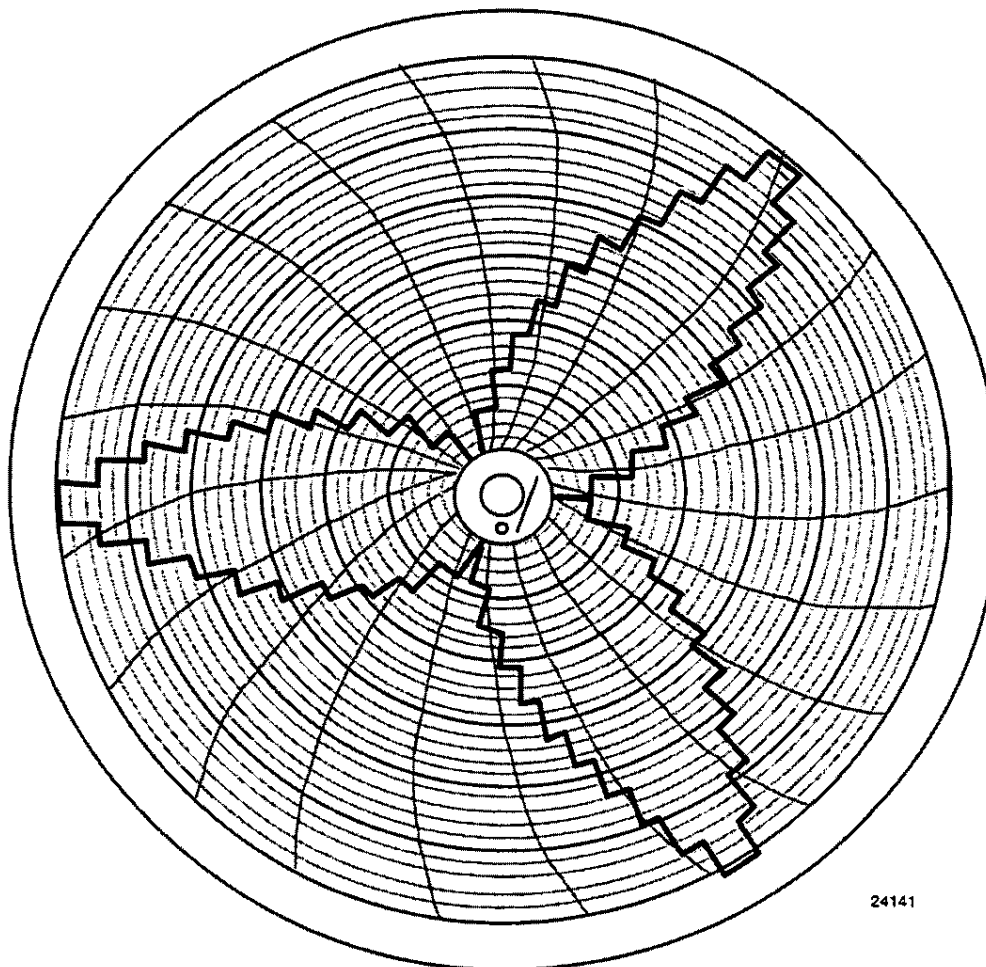

24141

Figure 3-4 Typical Step Test Chart Patterns

Startup

Introduction

The recorder is almost ready for operation when you have:

- mounted and wired the recorder as described in Section 2
- set up the recorder as described in subsection 3.2
- prepared the recorder as described in subsection 3.3.2

The only remaining tasks are aligning the chart time and applying power.

Procedure

To set the chart time and apply power, follow the procedure in Table 3-6. (See also Figure 3-5.)

Table 3-6 Startup Procedure

Step	Action
1	Open the door.
2	Pull up the pen lifter to raise the pen(s) from the chart plate.
3	Grasp the locating pin and turn the chart until the desired time line on the chart is aligned with the time index on the chart plate and pen 1. Push down the pen lifter to return the pen(s) to the chart.
4	Close the door and apply power.
5	The pen(s) will move into position and the recorder will start to track the input value.

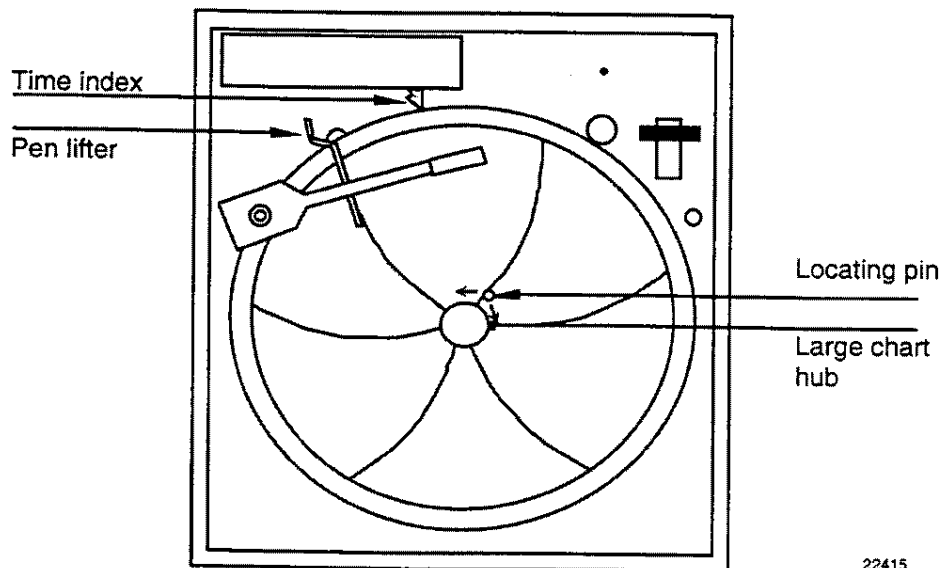

22415

Figure 3-5 Setting Chart Time to Time Index