

## Communication

### Introduction

If the recorder hardware supports optional Modbus RTU communication, the communication link is wired to the terminal block on the communication board in the upper left corner of the case.

### ATTENTION

Network address, baud rate, and transmitter delay are configurable for models with a display (see *Section 4*).

For models without a display the address of pen 1 is fixed at 127, baud rate is fixed at 9600, and there is no transmitter delay. Only one pen channel with the fixed address of 127 can be on the network. Pen channel 2, if present in the recorder, cannot communicate. (Display is required to configure a unique address for the second pen to communicate.)

### Procedure

Refer to Figure 2-12 while following the procedure in Table 2-10 to install communication wiring.

**Table 2-10 Communication Wiring**

Step	Action
<b>ATTENTION</b> To avoid damaging the recorder, be sure that you install the power wires into the correct screw terminals as shown in Figure 2-7, Figure 2-8, or Figure 2-9.	
1	Open the recorder door. Loosen the captive screw in the chart plate and swing the plate out.
2	Locate the terminal block on the optional communication printed circuit assembly in the upper left corner of the case. (See Figure 2-12.)
3	Run the communication wires through the appropriate conduit hole (see Figure 2-5 and Figure 2-6). DO NOT bundle them with the power wires.
4	Strip 1/4-inch maximum of insulation from the end of each wire and form end to fit under a screw connection.
5	Insert the wires under the appropriate screws (labeled on assembly). Tighten the screws to secure the wires.

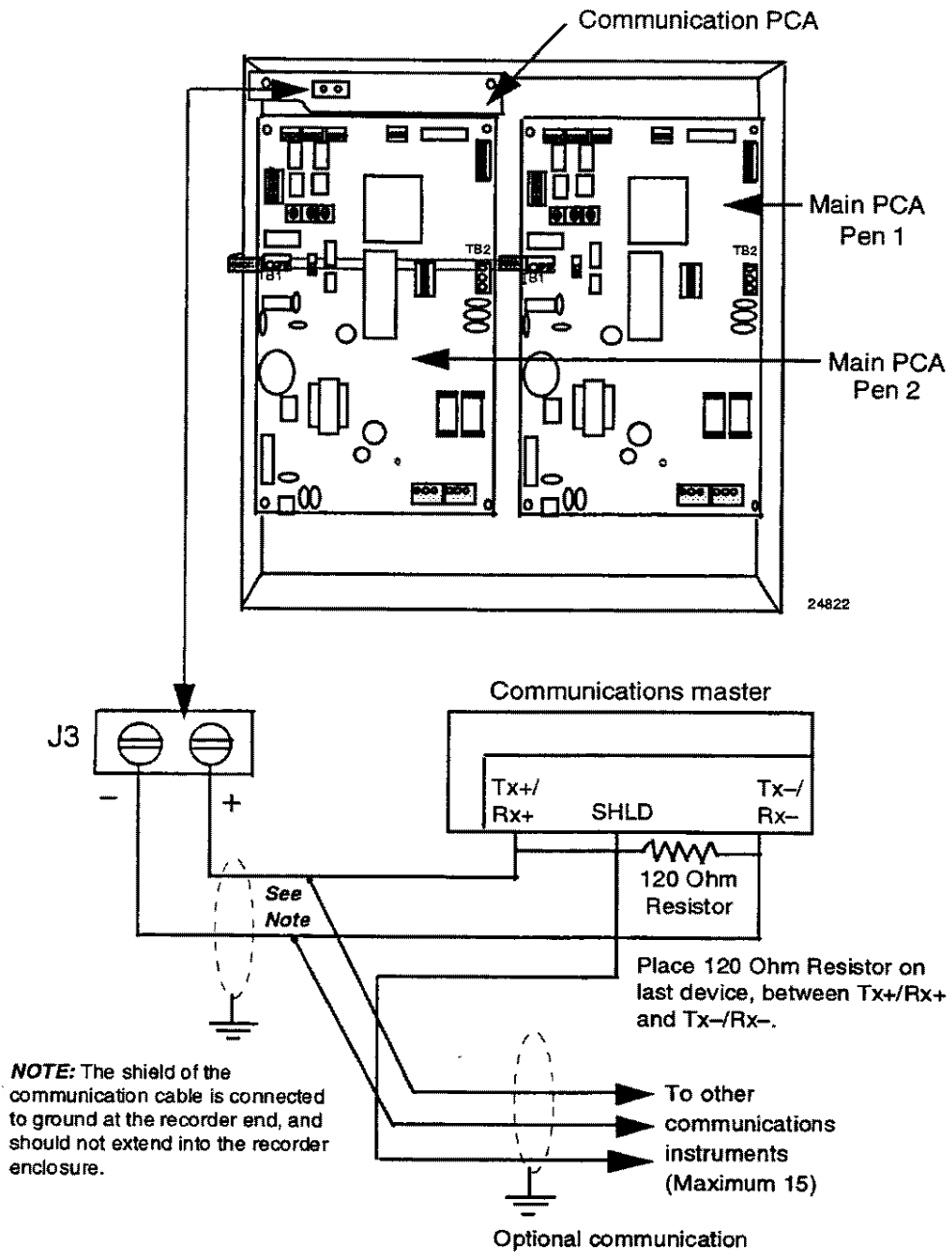

Figure 2-12 Communication Wiring

## Communication Set Up Group

### Introductions

If the hardware supports the Modbus communication option, use the prompts in the communication set up group to configure communication parameters.

### Communication group prompts

Table 4-16 lists the function prompt in the communication set up group.

For a 2-pen recorder, the desired input channel is displayed on the left side of the operator interface. Press **FUNC** to select channel.

Press **SETUP** key until "COMM" appears in the lower display.

Press **FUNC** key to select the parameter.

### ATTENTION

Each pen channel must have its own unique address. However, set the same baud rate and transmitter delay for both pens.

Table 4-16 Communication Parameter Definitions

Lower Display Prompt	Upper Display Range of Setting or Selection	Parameter Definition
COMM	DIS <i>[factory setting]</i> ENAB	<b>COMMUNICATION ENABLE</b> —Enable/disable communication.
ADDRES	1 to 99 <i>[factory setting = 0]</i>	<b>ADDRESS</b> —Specify the pen channel's address on the network.
BAUD	300 600 1200 2400 4800 9600 <i>[factory setting]</i> 19.2K	<b>BAUD RATE</b> —Specify the baud rate used by all devices on the network.
XmtDLY	NONE <i>[factory setting]</i> 10ms 20ms 30ms 40ms 50ms	<b>TRANSMITTER DELAY</b> —Specify the minimum delay between the end of a received message and the start of the response message.