

---

## Model DR 4300 Circular Chart Recorder Replacement Instruction

### Transmitter Power Assembly Kit (51204403-501)

---

**Document Number**      Form: 43-DR-33-73A  
                                    Effective: 8/98  
                                    Supersedes: 43-DR-33-73

---

**Kit Contents**              This Transmitter Power Assembly Kit contains the following parts:

- Transmitter Power Assembly
- Plastite #6 x 3/8 Screws (2)

---

**Summary**                    Enclosed are a new transmitter power assembly and parts for your DR4300 recorder. Use the following procedure to install the new power assembly in your recorder.

**WARNING**      Never access components inside the case with power applied.

---

*Continued next page*

**Component Location** Refer to Figure 1 and Figure 2 for component locations and Table 1 for the installation/replacement procedure.

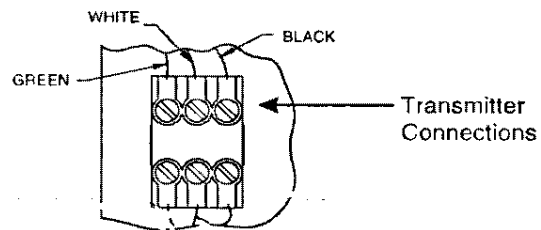
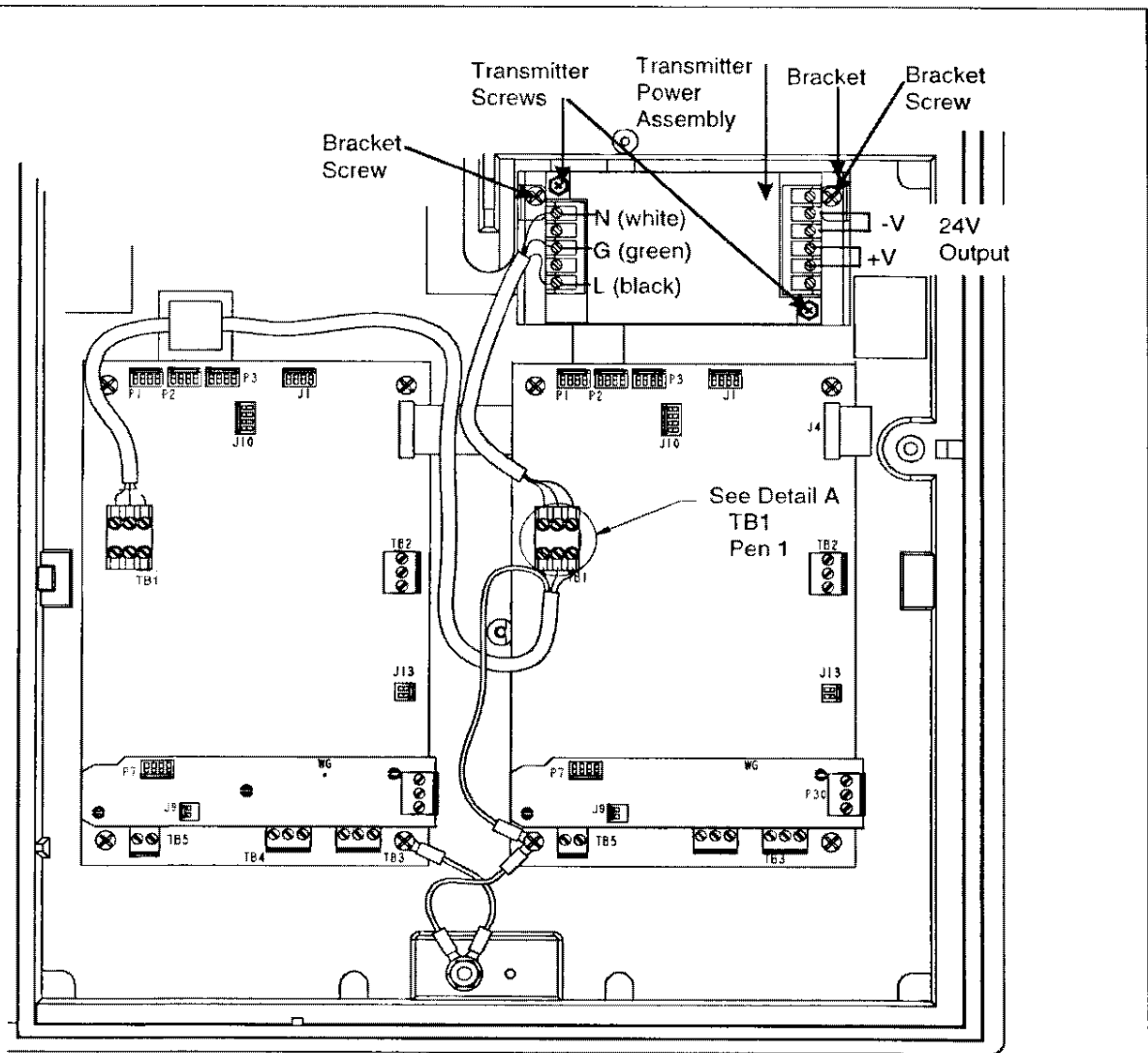

DETAIL A  
TB1 - Pen 1

24231

**Figure 1 - Component Location**

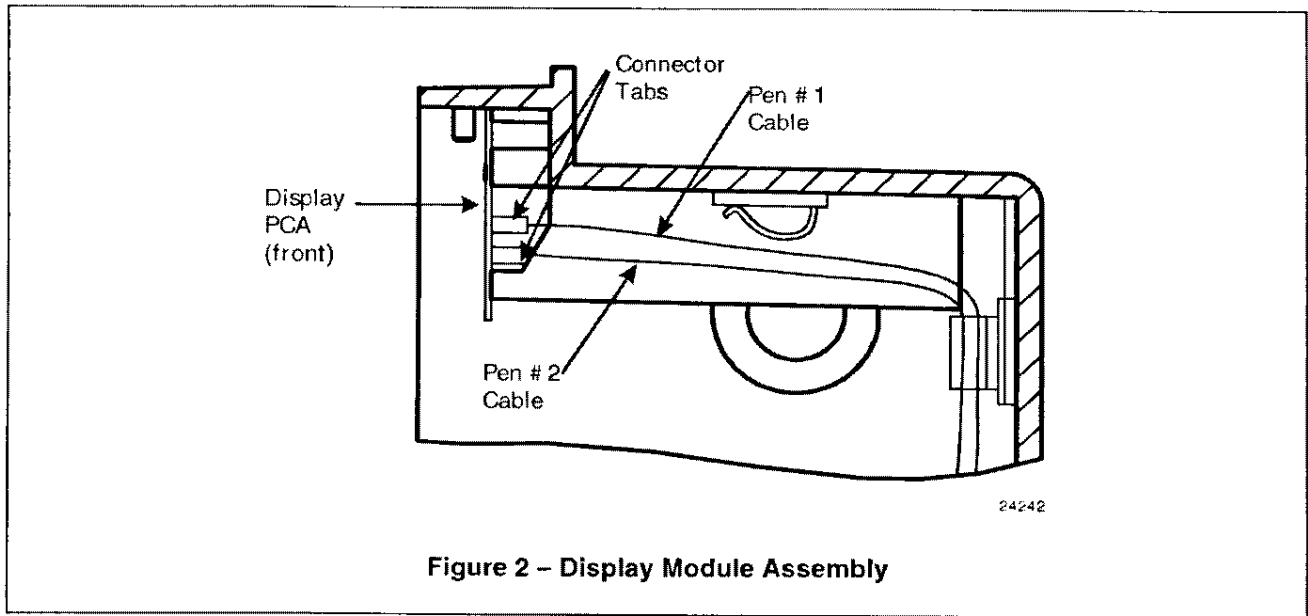

Figure 2 – Display Module Assembly

**Installation Procedure** Follow the procedure in Table 1 to install or replace the new transmitter power assembly in your recorder.

**Table 1 – Transmitter Power Assembly Installation**

Step	Action
1	Power down the recorder. Open the chart door and swing the chart plate out.
2	<p><i>If you have a recorder with a display module, remove the display module printed circuit assembly (PCA) for better access to the transmitter power assembly (Figure 2).</i></p> <ul style="list-style-type: none"> <li>• Remove the two screws holding the display module to the top of the case.</li> <li>• If cable(s) need to be disconnected from the back side of the display, remove by pulling outward on the end tabs of the cable connector(s). Note orientation of cable(s).</li> </ul>
3	<p><i>If you are installing a new transmitter power assembly, go to Step 4.</i></p> <p><i>If you are replacing the transmitter power assembly, go to Step 5.</i></p>

*Table 1 continued on next page*

**Table 1 – Transmitter Power Assembly Installation, continued**

Step	Action
<p><b>4</b></p>	<p>Install the new transmitter power assembly:</p> <ul style="list-style-type: none"> <li>• Secure the bracket with the new transmitter power assembly to two bosses on case.</li> <li>• Connect cable to TB1 on the Main PCA (Figure 1).</li> </ul> <p><i>If you have a recorder with a display module, go to Step 6.</i>  <i>If the recorder does not have a display module, go to Step 7.</i></p>
<p><b>5</b></p>	<p>Replace the existing transmitter power assembly with the new one:</p> <ul style="list-style-type: none"> <li>• Locate the transmitter power assembly and disconnect wiring from terminals (Figure 1).</li> <li>• Remove two screws holding the transmitter power assembly to the mounting bracket.</li> <li>• Using the screws provided, mount the new transmitter power assembly to the bracket.</li> <li>• Reconnect the wiring:               <ul style="list-style-type: none"> <li>• N: white wire</li> <li>• G: green wire</li> <li>• L: black wire</li> <li>• <math>\pm 24V</math> output</li> </ul> </li> </ul> <p><i>If you have a recorder with a display module, go to Step 6.</i>  <i>If the recorder does not have a display module, go to Step 7.</i></p>
<p><b>6</b></p>	<p>Reinstall the display module PCA (Figure 2).</p> <ul style="list-style-type: none"> <li>• If necessary, reconnect cable(s) on back side of display module by inserting cable in connector and pushing in on end of connector tabs to lock cable in place.</li> <li>• Using the screws removed in Step 2, secure the display module to the top of the case.</li> </ul>
<p><b>7</b></p>	<p>Close the chart door and apply power. Check for normal display indication, if applicable.</p>