



UDC 3200 Application Note



WARNING—SHOCK HAZARD

INPUT CALIBRATION MAY REQUIRE ACCESS TO HAZARDOUS LIVE CIRCUITS, AND SHOULD ONLY BE PERFORMED BY QUALIFIED SERVICE PERSONNEL. MORE THAN ONE SWITCH MAY BE REQUIRED TO DE-ENERGIZE UNIT BEFORE CALIBRATION.

Overview

Introduction

This section describes the field calibration procedures for Input 1 and Input 2. All input actuations in every UDC3200 controller are fully factory-calibrated and are ready for configuration by the user. Field Calibration can improve the accuracy of the Controller if necessary for a particular application.

CAUTION

The field calibration will be lost if a change in input type configuration is implemented at a later time. The original factory calibration data remains available for later use after a field calibration is done.

Calibration Steps

Use the following steps when calibrating an input.

Step	Action
1	Find the minimum and maximum range values for your PV input range from Table 1
2	Disconnect the field wiring and find out what equipment you will need to calibrate.
3	Wire the calibrating device to your controller according to the set up wiring instructions for your particular input
4	Follow the calibration procedure given for Input #1 or Input #2



UDC 3200 Application Note

Minimum and Maximum Range Values

Select the Range Values

Calibrate the controller for the minimum (0 %) and maximum (100 %) range values of your particular input type. Two input controllers will need to have each input calibrated separately.

Select the Voltage, Current or Resistance equivalents for 0 % and 100 % range values from Table 1. Use these values when calibrating your controller.

Table 1 Voltage, Milliamp and Resistance Equivalents for Input Range Values

Sensor Type	PV Input Range		Range Values	
	°F	°C	0 %	100 %
Thermocouples (per ITS-90)				
B	0 to 3300	-18 to 1816	-0.100 mV	13.769 mV
E TC H	-454 to 1832	-270 to 1000	-9.835 mV	76.373 mV
E TC L	-200 to 1100	-129 to 593	-6.472 mV	44.455 mV
J TC H	0 to 1600	-18 to 871	-0.886 mV	50.060 mV
J TC M	20 to 900	-7 to 482	-0.334 mV	26.400 mV
J TC L	20 to 550	-7 to 288	-0.334 mV	15.650 mV
K TC H	0 to 2400	-18 to 1816	-0.692 mV	52.952 mV
K TC M	-20 to 1200	-29 to 649	-1.114 mV	26.978 mV
K TC L	-20 to 750	-29 to 399	-1.114 mV	16.350 mV
NNM H	32 to 2500	0 to 1371	0.000 mV	71.773 mV
NNM L	32 to 1260	0 to 682	0.000 mV	31.825 mV
NIC H	0 to 2372	-18 to 1300	-0.461 mV	47.513 mV
NIC L	0 to 1472	-18 to 800	-0.461 mV	28.455 mV
R TC	0 to 3100	-18 to 1704	-0.090 mV	20.281 mV
S TC	0 to 3100	-18 to 1704	-0.092 mV	17.998 mV
T TC H	-300 to 700	-184 to 371	-5.341 mV	19.097 mV
T TC L	-200 to 500	-129 to 260	-4.149 mV	12.574 mV
W TC H	0 to 4200	-18 to 2315	-0.234 mV	37.075 mV
W TC L	0 to 2240	-18 to 1227	-0.234 mV	22.283 mV
Thermocouple Differential *	-50 to 150	-46 to 66	-1.54 mV	4.62 mV



UDC 3200 Application Note

Sensor Type	PV Input Range		Range Values	
	°F	°C	0 %	100 %
Honeywell Radiamatic				
Type RH	0 to 3400	-18 to 1871	0.00 mV	57.12 mV
Type RI **	0 to 3400	-18 to 1871	0.00 mV	60.08 mV
RTD Alpha = 0.00385 per IEC-60751 (1995)				
100 ohms	-300 to 1200	-184 to 649	25.202 ohms	329.289 ohms
100 ohms (low)	-300 to 300	-184 to 149	25.202 ohms	156.910 ohms
200 ohms	-300 to 1200	-184 to 649	50.404 ohms	658.578 ohms
500 ohms	-300 to 1200	-184 to 649	126.012 ohms	1646.445 ohms
Linear				
Milliamps	4 to 20 mA 0 to 20 mA		4.00 mA 0.00 mA	20.00 mA 20.00 mA
Millivolts	0 to 10 mV 0 to 50 mV 0 to 100 mV		0.00 mV 0.00 mV 0.00 mV	10.00 mV 50.00 mV 100.00 mV
Volts	1 to 5 Volts 0 to 5 Volts 0 to 10 Volts		1.00 Volts 0.00 Volts 0.00 Volts	5.00 Volts 5.00 Volts 10.00 Volts
Carbon Oxygen	0 to 1250 mV -30 to 510 mV		0.00 mV -30.00 mV	1250.00 mV 510.00 mV

* The Factory Calibrated millivolt values for the Thermocouple Differential Input are for a pair of J thermocouples at an ambient temperature mean of 450°F / 232°C. Other thermocouple types and ambient temperature means may be accomplished via Field Calibration of the input, with the range value limits being -4 mV to +16 mV for the zero and span values.

** The range values for Radiamatic Type RI are customer configurable within the limits shown.



UDC 3200 Application Note

Preliminary Information

Disconnect the Field Wiring

Tag and disconnect any field wiring connected to the input (#1 or #2) terminals on the rear of the controller.

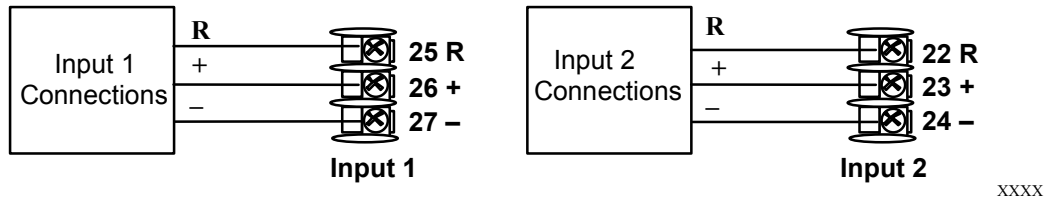

Figure 1 Input 1 and Input 2 Wiring Terminals

Equipment Needed

Table 2 lists the equipment you will need to calibrate the specific types of inputs that are listed in the table. You will need a screwdriver to connect these devices to your controller.

Table 2 Equipment Needed

Type of Input	Equipment Needed
Thermocouple Inputs (Ice Bath)	<ul style="list-style-type: none"> • A calibrating device with at least ± 0.02 % accuracy for use as a signal source such as a millivolt source. • Thermocouple extension wire that corresponds with the type of thermocouple that will be used with the controller input. • Two insulated copper leads for connecting the thermocouple extension wire from the ice baths to the mV source. • Two containers of crushed ice.
Thermocouple Inputs (T/C Source)	<ul style="list-style-type: none"> • A calibrating device with at least ± 0.02 % accuracy for use as a signal source such as a millivolt source. • Thermocouple extension wire that corresponds with the type of thermocouple that will be used with controller input.
RTD (Resistance Thermometer Device)	<ul style="list-style-type: none"> • A decade box, with at least ± 0.02 % accuracy, capable of providing stepped resistance values over a minimum range of 0 to 1650 ohms with a resolution of 0.001 ohm. • Three insulated copper leads of equal length for connecting the decade box to the controller.
Milliampere, Millivolt, Volts, and Radiamatic	<ul style="list-style-type: none"> • A calibrating device with at least ± 0.02 % accuracy for use as a signal source. • Two insulated copper leads for connecting the calibrator



UDC 3200 Application Note

Type of Input	Equipment Needed
and Radiamatic	to the controller.
	<ul style="list-style-type: none"> Place current source at zero before switching ON. Do not switch current sources OFF/ON while connected to the UDC3200 input.

Input 1 or 2 Set Up Wiring

Thermocouple Inputs Using an Ice Bath

Refer to Figure 2 and wire the controller according to the procedure given in Table 3.

Table 3 Set Up Wiring Procedure for Thermocouple Inputs Using an Ice Bath

Step	Action
1	Connect the copper leads to the calibrator.
2	Connect a length of thermocouple extension wire to the end of each copper lead and insert the junction points into the ice bath.
3	Connect the thermocouple extension wires to the terminals for Input #1. See Figure 2.

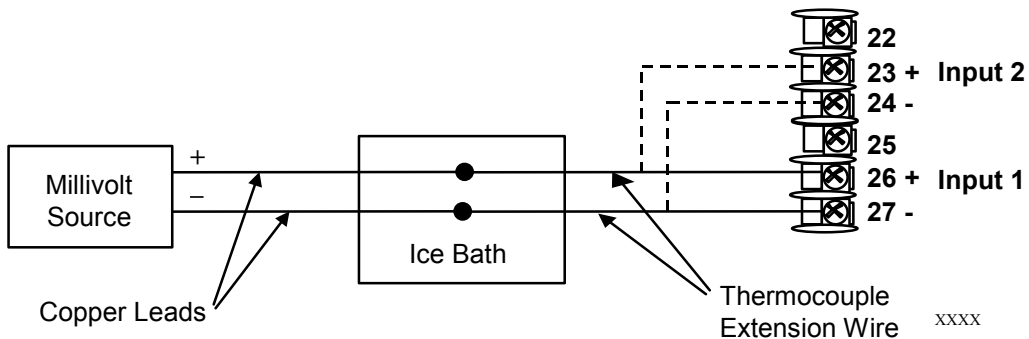

Figure 2 Wiring Connections for Thermocouple Inputs Using an Ice Bath



UDC 3200 Application Note

Thermocouple Inputs Using a Thermocouple Source

Refer to Figure 3 and wire the controller according to the procedure given in Table 4.

Table 4 Set Up Wiring Procedure for Thermocouple Inputs using Thermocouple Source

Step	Action
1	Connect the thermocouple extension wires to the terminals for Input #1 as shown in Figure 3.

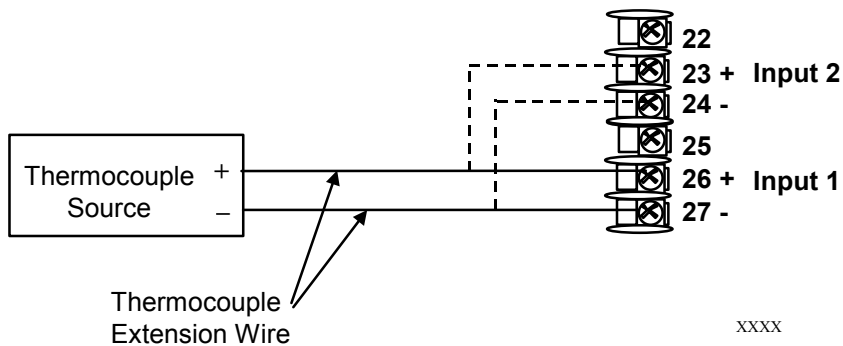

Figure 3 Wiring Connections for Thermocouple Inputs Using Thermocouple Source

RTD Inputs

Refer to Figure 4 and wire the controller according to the procedure given in Table 5.

Table 5 Set Up Wiring Procedure for RTD Inputs

Step	Action
1	Connect the copper leads from the calibrator to the Input #1 terminals as shown in Figure 4.

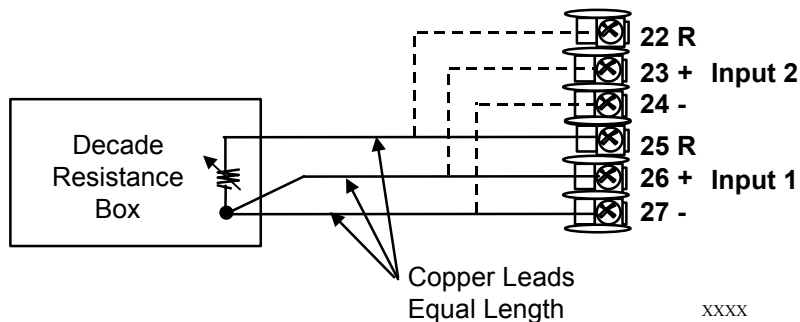

Figure 4 Wiring Connections for RTD (Resistance Thermometer Device)



UDC 3200 Application Note

Radiamatic, Millivolts, Volts or Thermocouple Differential Inputs

Refer to Figure 5 and wire the controller according to the procedure given in Table 6.

Table 6 Set Up Wiring Procedure for Radiamatic, Millivolts, Volts or Thermocouple Differential Inputs (Except 0-10 Volts)

Step	Action
1	Connect the copper leads from the calibrator to the Input #1 terminals as shown in Figure 5.
2	Place current/voltage source at zero before switching on.
3	Do not switch current/voltage source ON/OFF while connected to the instrument.

ATTENTION

For Radiamatic inputs only, set Emissivity value to 1.0.

See:

- **Error! Reference source not found.** Set Up prompt INPUT 1, function prompt EMISSIV 1
- **Error! Reference source not found.** Set Up prompt INPUT 2, function prompt EMISSIV 2

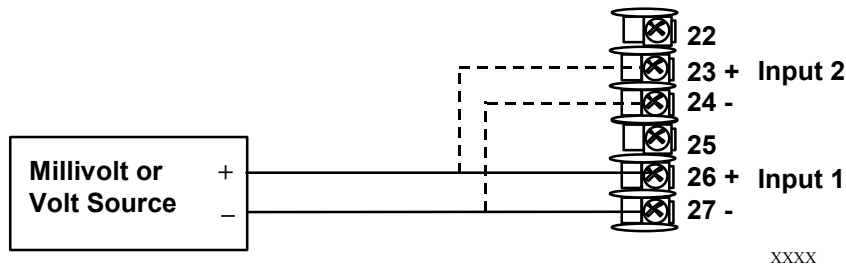

Figure 5 Wiring Connections for Radiamatic, Thermocouple Differential, Millivolts or Volts (Except 0 to 10 Volts)



UDC 3200 Application Note

0 to 10 Volts

Refer to Figure 6 and wire the controller according to the procedure given in Table 7.

Table 7 Set Up Wiring Procedure for 0 to 10 Volts

Step	Action
1	Connect the copper leads from the calibrator to the Input #1 terminals as shown in Figure 6.
2	Place voltage source at zero before switching on.
3	Do not switch voltage source ON/OFF while connected to the instrument.

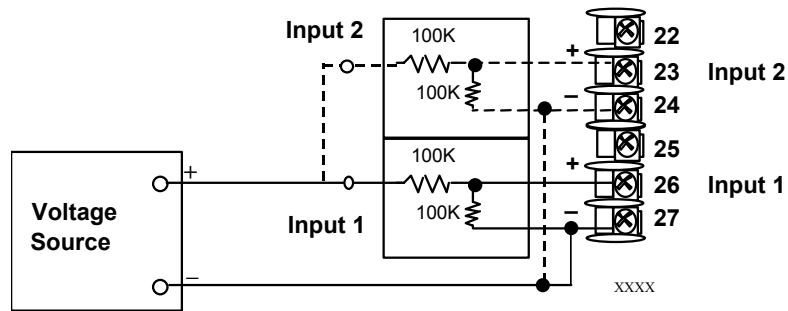

Figure 6 Wiring Connections for 0 to 10 Volts

Milliamperes

Refer to Figure 7 and wire the controller according to the procedure given in Table 8.

Table 8 Set Up Wiring Procedure for Milliampere Inputs

Step	Action
1	Connect the copper leads from the calibrator to the Input #1 terminals as shown in Figure 7.
2	Place current source at zero before switching on.
3	Do not switch current source ON/OFF while connected to the instrument.

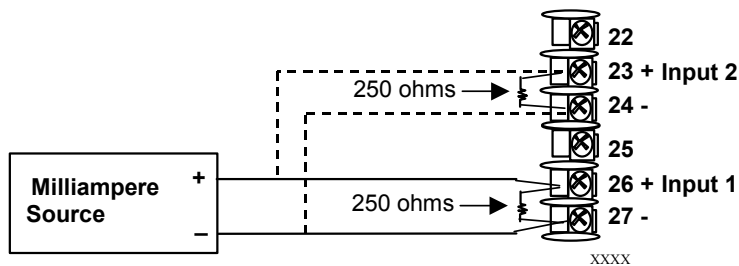

Figure 7 Wiring Connections for 0 to 20 mA or 4 to 20 mA Inputs



UDC 3200 Application Note

Input 1 or 2 Calibration Procedure

Preliminary Steps

Apply power and allow the controller to warm up for 30 minutes before you calibrate.

Make sure you have LOCK set to NONE.

See Table 1 for Voltage vs. Resistance equivalents or 0 % and 100 % range values.





CAUTION

For linear inputs, avoid step changes in inputs. Vary smoothly from initial value to final 100 % value.

Procedure

The calibration procedure for Input #1 or 2 is listed in Table 9.

Table 9 Input 1 or 2 Calibration Procedure

Step	Operation	Press	Result
1	Enter Calibration Mode	 until you see 	<i>Upper Display = CALIB</i> <i>Lower Display = INPUTn [n=1 or 2]</i>
		 or 	You will see: <i>Upper Display = DISABLE</i> <i>Lower Display = CAL INn [n=1 or 2]</i>
			The calibration sequence is enabled and you will see: <i>Upper Display = BEGIN</i> <i>Lower Display = CAL INn [n=1 or 2]</i> At the completion of the sequence, the selection automatically reverts to disable.



UDC 3200 Application Note

Step	Operation	Press	Result
------	-----------	-------	--------

2 Calibrate 0 %



You will see:

3 Calibrate 100 %



You will see:

Upper Display = **APPLY**
 Lower Display = **INn SPAN [n=1 or 2]**

- Adjust your calibration device to an output signal equal to the 100 % range value for your particular input sensor. See **Error! Reference source not found.** for Voltage, Degrees, or Resistance equivalents for 100 % range values.
- Wait 15 seconds, and

If ...	Then ...
you are calibrating a Thermocouple input	go to step 4
you are calibrating other than a Thermocouple input	go to step 5

4 Check the Cold Junction Temperature





The calculations for zero and span are now stored and you will see:

Upper Display = The cold junction temperature at the rear terminals
 Lower Display = **CJTEMP**

The value in the upper display is in tenths of a degree. It is the current reading of the temperature as measured at the thermocouple terminals and recognized by the controller. You can change this



UDC 3200 Application Note

Step	Operation	Press	Result
			value, if it is in error, using the ▲ or ▼ keys.
			WARNING: The accuracy of the controller is directly affected by the accuracy of this value. It is recommended that this value not be changed under normal circumstances.
5	Exit the Calibration Mode	 then 	The controller stores the calibration constants and exits the calibration mode.
