



UDC 3500 Application Note

Calibration Steps

Use the following steps when calibrating an input.

Step	Action
1	Find the minimum and maximum range values for your PV input range from Table Error! No text of specified style in document.-1.
2	Disconnect the field wiring and find out what equipment you will need to calibrate.
3	Wire the calibrating device to your controller according to the set up wiring instructions for your particular input (Subsection 0)
4	Follow the calibration procedure given for Input #1 or Input #2 (Subsection 0).

Minimum and Maximum Range Values

Select the Range Values

Calibrate the controller for the minimum (0 %) and maximum (100 %) range values of your particular input type. Instruments with two or more analog inputs will need to have each input calibrated separately.

Select the Voltage, Current or Resistance equivalents for 0 % and 100 % range values from Table Error! No text of specified style in document.-1. Use these values when calibrating your controller.

Table Error! No text of specified style in document.-1 Voltage, Milliamp and Resistance Equivalents for Input Range Values

Sensor Type	PV Input Range		Range Values	
	°F	°C	0 %	100 %
Thermocouples (per ITS-90)				
B TC	0 to 3300	-18 to 1816	-0.100 mV	13.769 mV
E TC H	-454 to 1832	-270 to 1000	-9.835 mV	76.373 mV
E TC L	-200 to 1100	-129 to 593	-6.472 mV	44.455 mV
J TC H	0 to 1600	-18 to 871	-0.886 mV	50.060 mV
J TC M	20 to 900	-7 to 482	-0.334 mV	26.400 mV
J TC L	20 to 550	-7 to 288	-0.334 mV	15.650 mV
K TC H	0 to 2400	-18 to 1316	-0.692 mV	52.952 mV
K TC M	-20 to 1200	-29 to 649	-1.114 mV	26.978 mV
K TC L	-20 to 750	-29 to 399	-1.114 mV	16.350 mV
NNM H	32 to 2500	0 to 1371	0.000 mV	71.773 mV
NNM L	32 to 1260	0 to 682	0.000 mV	31.825 mV



UDC 3500 Application Note

Sensor Type	PV Input Range		Range Values	
	°F	°C	0 %	100 %
NIC H	0 to 2372	-18 to 1300	-0.461 mV	47.513 mV
NIC L	0 to 1472	-18 to 800	-0.461 mV	28.455 mV
PLAT H	32 to 2516	0 to 1380	0.000 mV	54.798 mV
PLAT L	32 to 1382	0 to 750	0.000 mV	31.272 mV
R TC	0 to 3100	-18 to 1704	-0.090 mV	20.281 mV
S TC	0 to 3100	-18 to 1704	-0.092 mV	17.998 mV
T TC H	-300 to 700	-184 to 371	-5.341 mV	19.097 mV
T TC L	-200 to 500	-129 to 260	-4.149 mV	12.574 mV
W TC H	0 to 4200	-18 to 2315	-0.234 mV	37.075 mV
W TC L	0 to 2240	-18 to 1227	-0.234 mV	22.283 mV
Thermocouple Differential *	-50 to 150	-46 to 66	-1.54 mV	4.62 mV
Honeywell Radiamatic				
Type RH	0 to 3400	-18 to 1871	0.00 mV	57.12 mV
Type RI **	0 to 3400	-18 to 1871	0.00 mV	60.08 mV
RTD Alpha = 0.00385 per IEC-60751 (1995)				
100 ohms	-300 to 1200	-184 to 649	25.202 ohms	329.289 ohms
100 ohms (low)	-300 to 300	-184 to 149	25.202 ohms	156.910 ohms
200 ohms	-300 to 1200	-184 to 649	50.404 ohms	658.578 ohms
500 ohms	-300 to 1200	-184 to 649	126.012 ohms	1646.445 ohms
1000 ohms	-300 to 1200	-184 to 649	252.020 ohms	3292.890 ohms
Linear				
Milliamps	4 to 20 mA 0 to 20 mA		4.00 mA 0.00 mA	20.00 mA 20.00 mA
Millivolts	0 to 10 mV 0 to 50 mV 0 to 100 mV 0 to 500 mV -10 to 10 mV		0.00 mV 0.00 mV 0.00 mV 0.00 mV -10.0 mV	10.00 mV 50.00 mV 100.00 mV 500.00 mV 10.00 mV
Volts	0 to 1 Volts 1 to 5 Volts 0 to 5 Volts 0 to 10 Volts -1 to 1 Volts		0.00 Volts 1.00 Volts 0.00 Volts 0.00 Volts -1.00 Volts	1.00 Volts 5.00 Volts 5.00 Volts 10.00 Volts 1.00 Volts
Carbon Oxygen	0 to 1250 mV -30 to 510 mV		0.00 mV -30.00 mV	1250.00 mV 510.00 mV



UDC 3500 Application Note

- * The Thermocouple Differential Input calibration voltages are for a pair of J thermocouples at an ambient temperature mean of 450°F / 232°C. Other thermocouple types and ambient temperature means may be accomplished via Field Calibration of the input, with the range value limits being -4 mV to +16 mV for the zero and span values. See Table Error! **No text of specified style in document.**-7.
- ** The range values for Radiamatic Type RI are customer configurable within the limits shown.



UDC 3500 Application Note

Preliminary Information

Disconnect the Field Wiring

Tag and disconnect any field wiring connected to the input terminals on the rear of the controller.

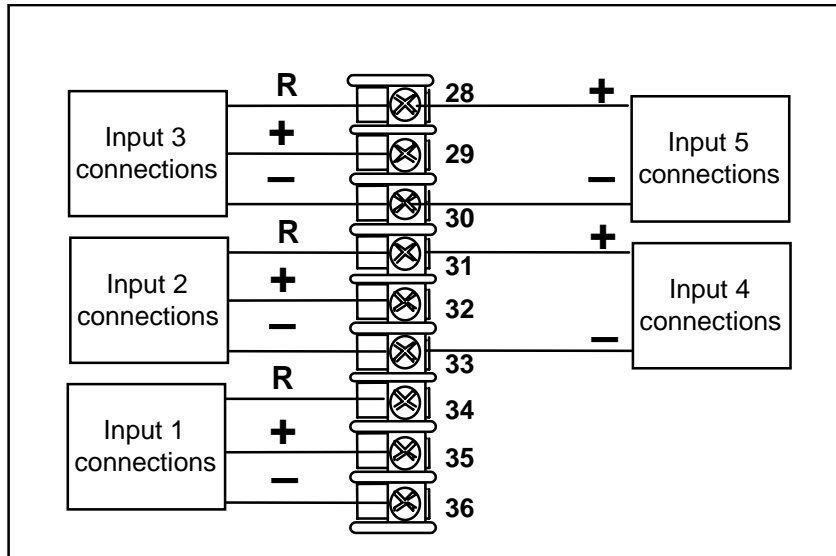

Figure Error! No text of specified style in document.-1 Input Wiring Terminals

Equipment Needed

Table Error! No text of specified style in document.-2 lists the equipment you will need to calibrate the specific types of inputs that are listed in the table. You will need a screwdriver to connect these devices to your controller.

Table Error! No text of specified style in document.-2 Equipment Needed

Type of Input	Equipment Needed
Thermocouple Inputs (Ice Bath)	<ul style="list-style-type: none"> • A calibrating device with at least ± 0.02 % accuracy for use as a signal source such as a millivolt source. • Thermocouple extension wire that corresponds with the type of thermocouple that will be used with the controller input. • Two insulated copper leads for connecting the thermocouple extension wire from the ice baths to the mV source. • Two containers of crushed ice or a commercially available ice bath.
Thermocouple Inputs (T/C Source)	<ul style="list-style-type: none"> • A calibrating device with at least ± 0.02 % accuracy for use as a signal source such as a millivolt source. • Thermocouple extension wire that corresponds with the type of thermocouple that will be used with controller input.



UDC 3500 Application Note

Type of Input	Equipment Needed
RTD (Resistance Thermometer Device)	<ul style="list-style-type: none">• A decade box, with at least ± 0.02 % accuracy, capable of providing stepped resistance values with a resolution of 0.001 ohm over the range of resistance needed.• Three insulated copper leads of equal length for connecting the decade box to the controller.
Milliampere, Millivolt, Volts, and Radiamatic	<ul style="list-style-type: none">• A calibrating device with at least ± 0.02 % accuracy for use as a signal source.• Two insulated copper leads for connecting the calibrator to the controller.• Place current source at zero before switching ON.• Do not switch current sources OFF/ON while connected to the instrument.



UDC 3500 Application Note

Input Set Up Wiring

Thermocouple Inputs Using an Ice Bath

Refer to Figure Error! No text of specified style in document.-2 and wire the controller according to the procedure given in Table Error! No text of specified style in document.-3.

Table Error! No text of specified style in document.-3 Set Up Wiring Procedure for Thermocouple Inputs Using an Ice Bath

Step	Action
1	Connect the copper leads to the calibrator.
2	<p>If using a physical Ice Bath: Connect a length of thermocouple extension wire to the end of each copper lead and insert the junction points into the ice bath.</p> <p>If using a commercial Ice Bath: Connect a length of thermocouple extension wire to the output side of the Ice Bath. Connect the calibrator with copper wires to the input side of the Ice Bath.</p>
3	Connect the thermocouple extension wires to the terminals for the input to be calibrated. See Figure Error! No text of specified style in document.-2.

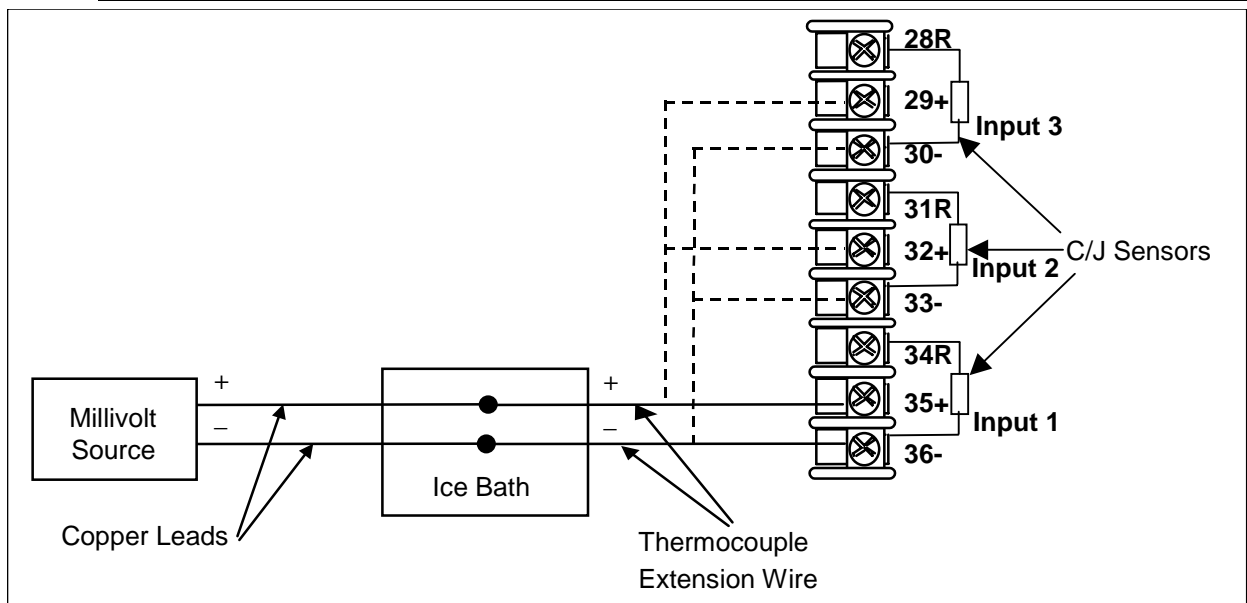

Figure Error! No text of specified style in document.-2 Wiring Connections for Thermocouple Inputs Using an Ice Bath



UDC 3500 Application Note

Thermocouple Inputs Using a Thermocouple Source

Refer to Figure Error! No text of specified style in document.-3 and wire the controller according to the procedure given in Table Error! No text of specified style in document.-4.

Table Error! No text of specified style in document.-4 Set Up Wiring Procedure for Thermocouple Inputs using a Thermocouple Source

Step	Action
1	Connect the thermocouple extension wires to the terminals for the input to be calibrated. See Figure Error! No text of specified style in document.-3.

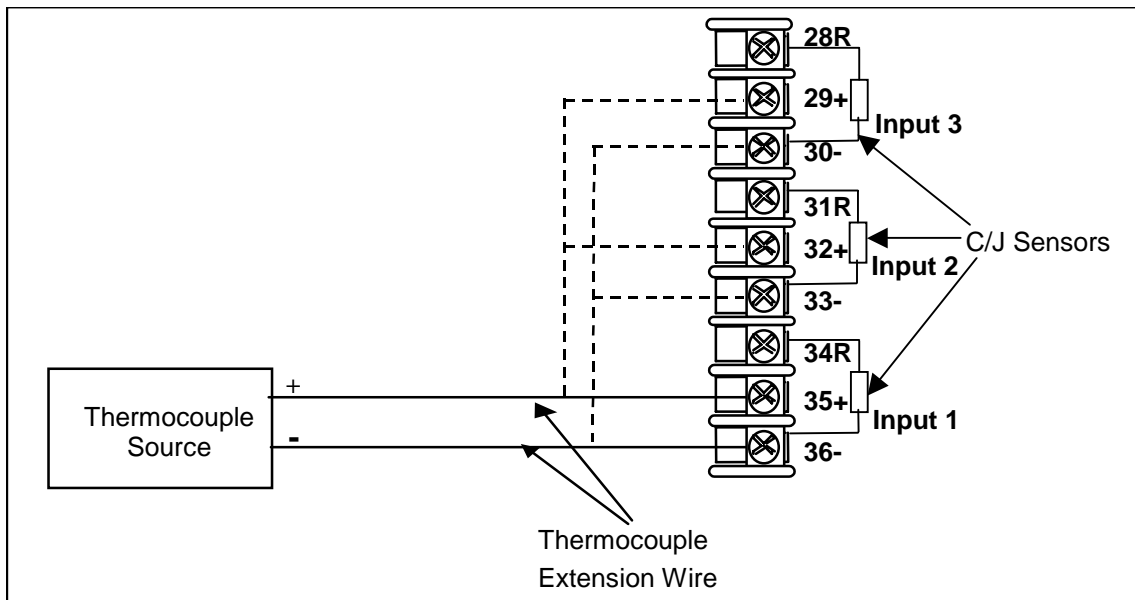

Figure Error! No text of specified style in document.-3 Wiring Connections for Thermocouple Inputs Using a Thermocouple Source



UDC 3500 Application Note

RTD Inputs

Refer to Figure Error! No text of specified style in document.-4 and wire the controller according to the procedure given in Table Error! No text of specified style in document.-5.

Table Error! No text of specified style in document.-5 Set Up Wiring Procedure for RTD Inputs

Step	Action
1	Connect the copper wires to the terminals for the input to be calibrated. See Figure Error! No text of specified style in document.-4.

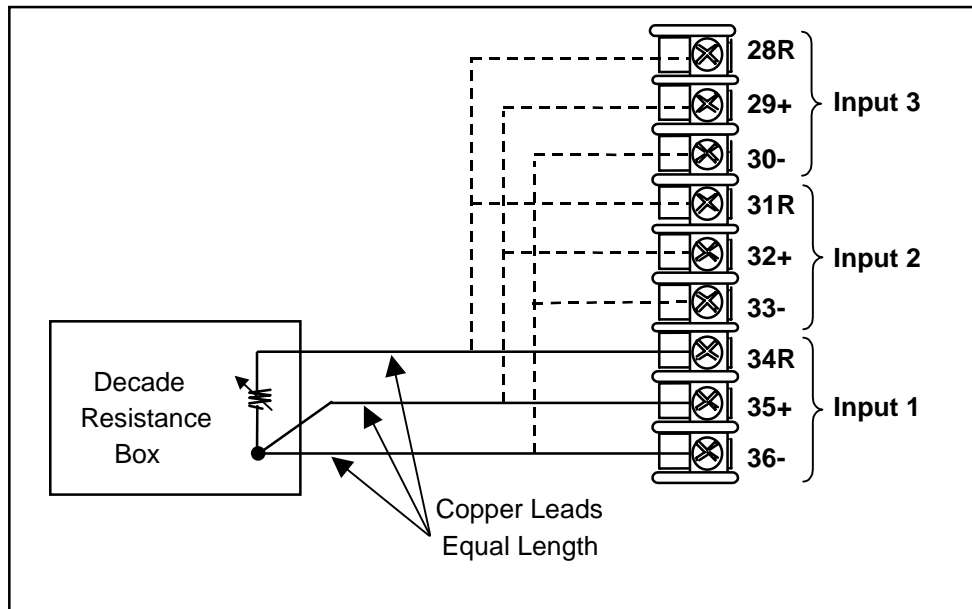

Figure Error! No text of specified style in document.-4 Wiring Connections for RTD (Resistance Thermometer Device)

ATTENTION

Decade Resistance Boxes are usually not accurate enough to meet the 0.02% accuracy requirement noted in Table Error! No text of specified style in document.-2. This can be overcome by performing a four-wire resistance measurement with a precision DMM and then adjusting the Decade Box to the correct zero and span resistance values as given in Table Error! No text of specified style in document.-1. Determine the proper zero and span resistance settings prior to attaching the Decade Box to the instrument. For best accuracy, measure with the DMM connected to the wire ends rather than directly to the Decade Box.



UDC 3500 Application Note

Radiamatic, Millivolts, Volts or Thermocouple Differential Inputs

Refer to Figure Error! No text of specified style in document.-5 and wire the controller according to the procedure given in Table Error! No text of specified style in document.-6.

Table Error! No text of specified style in document.-6 Set Up Wiring Procedure for Radiamatic, Millivolts, Volts or Thermocouple Differential Inputs (Except 0-10 Volts and -1 to 1 Volts)

Step	Action
1	Connect the copper leads from the calibrator to the Input #1 terminals as shown in Figure Error! No text of specified style in document.-5.
2	Place voltage source at zero before switching on.
3	Following calibration, turn off the voltage source prior to disconnecting it from the instrument.

ATTENTION

For Radiamatic inputs only, set Emissivity value to 1.0.

See:

Subsection Error! Reference source not found. – Error! Reference source not found. Set Up prompt INPUT 1, function prompt EMISSIV 1

Subsection Error! Reference source not found. – Error! Reference source not found. Set Up prompt INPUT 2, function prompt EMISSIV 2

Subsection Error! Reference source not found. – Error! Reference source not found. Set Up prompt INPUT 3, function prompt EMISSIV 3

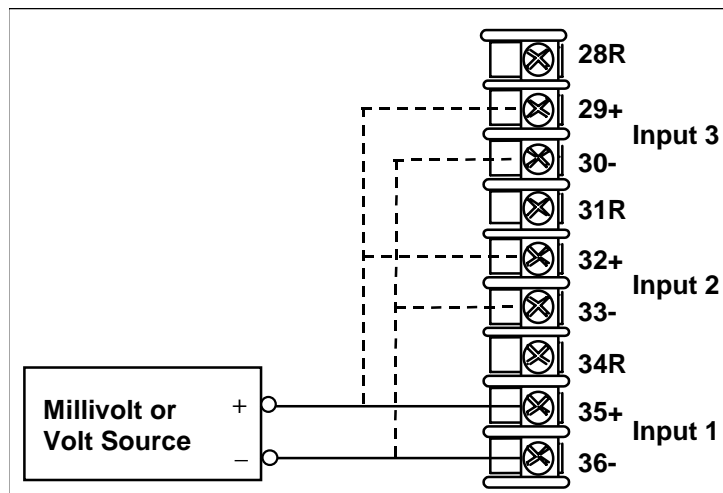

Figure Error! No text of specified style in document.-5 Wiring Connections for Radiamatic, Thermocouple Differential, Millivolts or Volts (Except 0 to 10 Volts and -1 to 1 Volts)



UDC 3500 Application Note



UDC 3500 Application Note

Table Error! No text of specified style in document.-7 Procedure to determine calibration voltages for Thermocouple Differential input types other than the Factory Setting

Step	Action
1	Obtain a copy of the ITS-90 Standard for the Thermocouple Type you will be using.
2	Find the thermoelectric voltage for the desired operating temperature.
3	Find the thermoelectric voltages for the temperatures -50°F and $+150^{\circ}\text{F}$ away from the desired operating temperature.
4	The zero calibration voltage will be thermoelectric voltage for the -50°F temperature minus the thermoelectric voltage for the desired operating temperature. This will be a negative voltage.
5	The span calibration voltage will be thermoelectric voltage for the $+150^{\circ}\text{F}$ temperature minus the thermoelectric voltage for the desired operating temperature. This will be a positive voltage.

For example: Determine the calibration voltage values for a pair of J-type thermocouples at an operating temperature of 450°F (this is equivalent to the Factory setting).

- The ITS-90 standard for the J thermocouple shows that the thermoelectric voltage for 450°F is 12.568 millivolts.
- The -50°F point would be 400°F . The ITS-90 standard shows that the thermoelectric voltage for 400°F is 11.025 millivolts.
- The $+150^{\circ}\text{F}$ point would be 600°F . The ITS-90 standard shows that the thermoelectric voltage for 600°F is 17.188 millivolts.
- The zero calibration voltage is thus 11.025 minus 12.568 millivolts or -1.543 millivolts (this can be rounded off to -1.54 millivolts without significant loss of accuracy).
- The span calibration voltage is thus 17.188 minus 12.568 millivolts or $+4.62$ millivolts.
- Use -1.54 millivolts for the Zero calibration value and $+4.62$ millivolts for the Span calibration value.



UDC 3500 Application Note

0 to 10 Volts or -1 to 1 Volts

Refer to Figure Error! No text of specified style in document.-6 and wire the controller according to the procedure given in Table Error! No text of specified style in document.-8.

Table Error! No text of specified style in document.-8 Set Up Wiring Procedure for 0 to 10 Volts or -1 to 1 Volts

Step	Action
1	Connect the copper leads from the calibrator to the input to be calibrated as shown in Figure Error! No text of specified style in document.-6.
2	Place voltage source at zero before switching on.
3	Following calibration, turn off the voltage source prior to disconnecting it from the instrument.

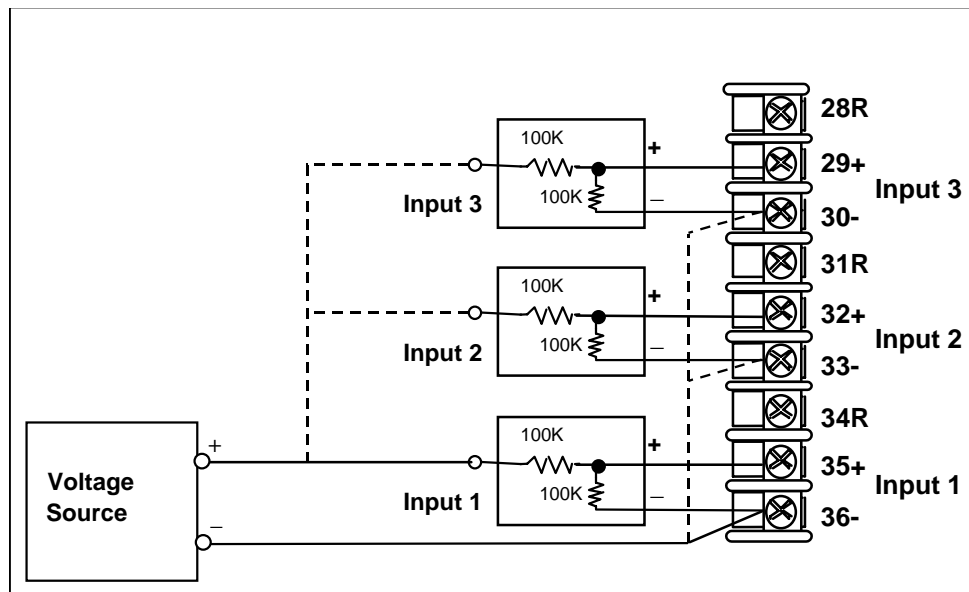

Figure Error! No text of specified style in document.-6 Wiring Connections for 0 to 10 Volts or -1 to 1 Volts



UDC 3500 Application Note

Milliamperes

Refer to Figure **Error! No text of specified style in document.-7** and wire the controller according to the procedure given in Table **Error! No text of specified style in document.-9**.

Table **Error! No text of specified style in document.-9** Set Up Wiring Procedure for Milliampere Inputs

Step	Action
1	Connect the copper leads from the calibrator to the input to be calibrated as shown in Figure Error! No text of specified style in document.-7 .
2	Place current source at zero before switching on.
3	Following calibration, turn off the current source prior to disconnecting it from the instrument.

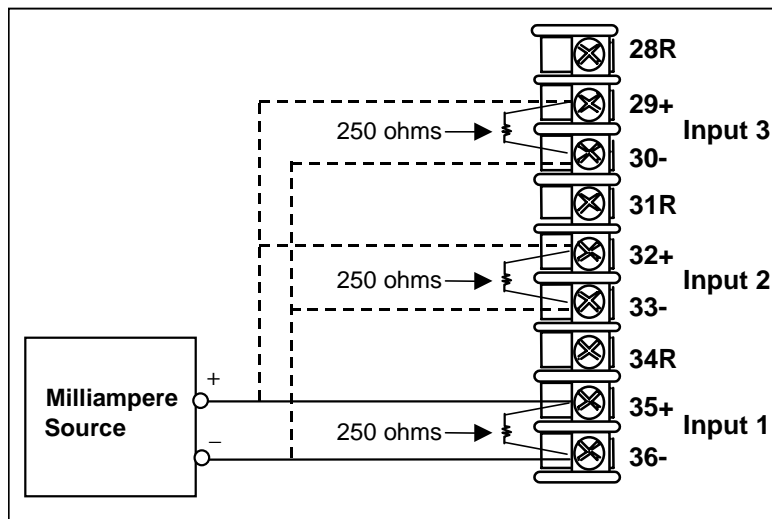

Figure **Error! No text of specified style in document.-7 Wiring Connections for Milliampere Inputs**



UDC 3500 Application Note

Dual High Level Voltage Inputs

Refer to Figure **Error! No text of specified style in document.-8** and wire the controller according to the procedure given in Table **Error! No text of specified style in document.-10**.

Table **Error! No text of specified style in document.-10** Set Up Wiring Procedure for Dual High Level Voltage Inputs

Step	Action
1	Connect the copper leads from the calibrator to the input to be calibrated as shown in Figure Error! No text of specified style in document.-8 .
2	Place voltage source at zero before switching on.
3	Following calibration, turn off the voltage source prior to disconnecting it from the instrument.

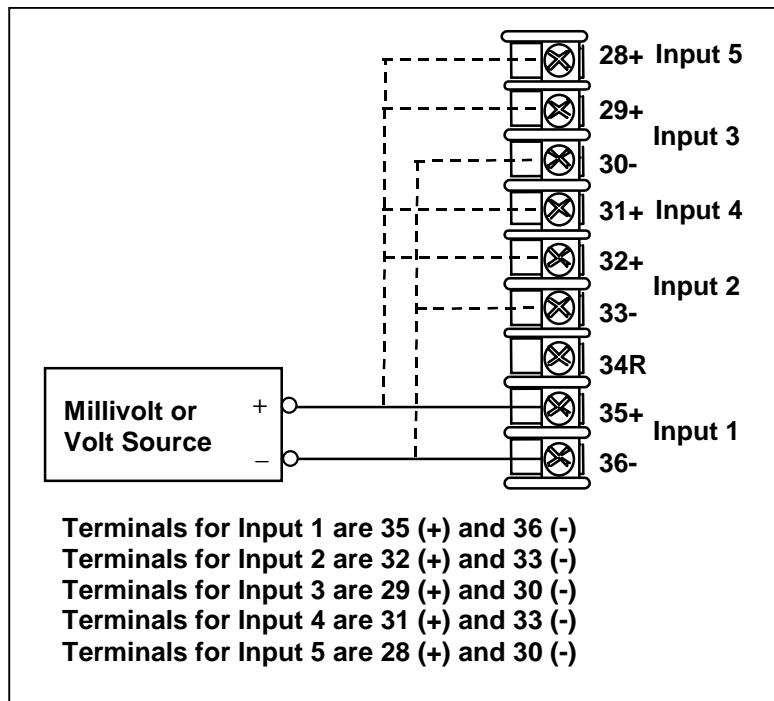

Figure **Error! No text of specified style in document.-8 Wiring Connections for Dual High Level Voltage Inputs**



UDC 3500 Application Note

Dual High Level Milliampere Inputs

Refer to Figure **Error! No text of specified style in document.-9** and wire the controller according to the procedure given in Table **Error! No text of specified style in document.-11**.

Table Error! No text of specified style in document.-11 Set Up Wiring Procedure for Dual High Level Milliampere Inputs

Step	Action
1	Connect the copper leads from the calibrator to the input to be calibrated as shown in Figure Error! No text of specified style in document.-9 .
2	Place current source at zero before switching on.
3	Following calibration, turn off the current source prior to disconnecting it from the instrument.

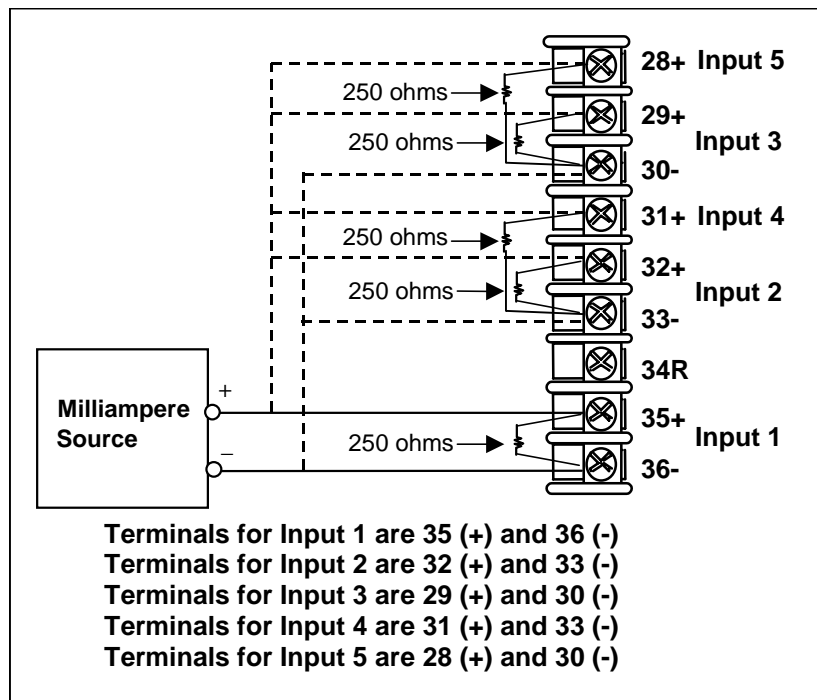

Figure Error! No text of specified style in document.-9 Wiring Connections for Dual High Level Milliampere Inputs



UDC 3500 Application Note

Input Calibration Procedure

Preliminary Steps

- Apply power and allow the controller to warm up for 30 minutes before you calibrate.
- Please read *Subsection 0* before beginning the procedure.
- **Make sure you have LOCK set to NONE. See *Subsection Error! Reference source not found.* – *Error! Reference source not found.***
- See Table *Error! No text of specified style in document.-1* for Voltage vs. Resistance equivalents or 0 % and 100 % range values.





CAUTION

For linear inputs, avoid step changes in inputs. Vary smoothly from initial value to final 100 % value.

Procedure

The calibration procedure for Input #1 or 2 is listed in Table *Error! No text of specified style in document.-12*.

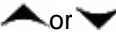
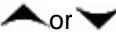
Table *Error! No text of specified style in document.-12* Input Calibration Procedure

Step	Operation	Press	Result
1	Enter Calibration Mode		<i>Upper Display = CALIB</i> <i>Lower Display = INPUTn [n=1 to 5]</i>
		until you see	
			You will see: <i>Upper Display = DISABLE</i> <i>Lower Display = CAL INn [n=1 to 5]</i>
		 or 	The calibration sequence is enabled and you will see: <i>Upper Display = BEGIN</i> <i>Lower Display = CAL INn [n=1 to 5]</i> At the completion of the sequence, the selection automatically reverts to disable.
2	Calibrate 0 %		You will see: <i>Upper Display = APPLY</i> <i>Lower Display = INn ZERO [n=1 to 5]</i>
			<ul style="list-style-type: none"> • Adjust your calibration device to an output signal equal to the 0 % range value for your particular input sensor. See Table <i>Error! No text of specified style in document.-1</i> for Voltage, Degrees, or Resistance equivalents for 0 % range values.







UDC 3500 Application Note

Step	Operation	Press	Result
------	-----------	-------	--------

- Wait 15 seconds, then go to the next step.

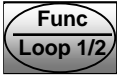

UDC 3500 Application Note

Step	Operation	Press	Result						
3	Calibrate 100 %		<p>You will see:</p> <p><i>Upper Display</i> = APPLY <i>Lower Display</i> = INn SPAN [n=1 to 5]</p> <ul style="list-style-type: none"> Adjust your calibration device to an output signal equal to the 100 % range value for your particular input sensor. See Table Error! No text of specified style in document.-1 for Voltage, Degrees, or Resistance equivalents for 100 % range values. Wait 15 seconds, and <table border="1" data-bbox="735 667 1430 829"> <thead> <tr> <th>If ...</th> <th>Then ...</th> </tr> </thead> <tbody> <tr> <td>you are calibrating a Thermocouple input</td> <td>go to step 4</td> </tr> <tr> <td>you are calibrating other than a Thermocouple input</td> <td>go to step 5</td> </tr> </tbody> </table>	If ...	Then ...	you are calibrating a Thermocouple input	go to step 4	you are calibrating other than a Thermocouple input	go to step 5
If ...	Then ...								
you are calibrating a Thermocouple input	go to step 4								
you are calibrating other than a Thermocouple input	go to step 5								
4	Check the Cold Junction Temperature		<p>The calculations for zero and span are now stored and you will see:</p> <p><i>Upper Display</i> = The temperature of the Cold Junction Sensor mounted on the rear terminals <i>Lower Display</i> = CJTEMP</p> <p>The value in the upper display is in tenths of a degree. It is the current reading of the cold junction temperature as measured by the controller. This value can be changed by using the ▲ and ▼ keys.</p> <p>WARNING It is recommended that this value not be changed under normal circumstances. Changing this value will not change the thermocouple reading on your instrument. Instead, it changes the effect of cold junction temperature compensation for future ambient temperature changes. If you wish to adjust the temperature reading of your instrument following a Field Calibration, then use the Input Bias setting. See Section Error! Reference source not found. (Input 1), Section Error! Reference source not found. (Input 2) or Section Error! Reference source not found. (Input 3).</p>						
5	Exit the Calibration Mode	 then 	<p>The controller stores the calibration constants and exits the calibration mode.</p>						