

Ignition Timing - Automotive

SOLID STATE

AP 00244

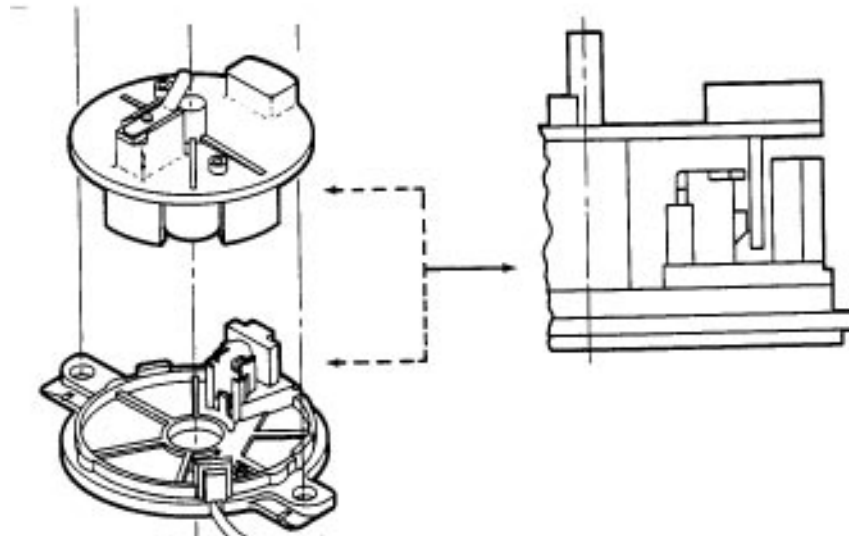

PRODUCT

Vane sensor

APPLICATION DESCRIPTION

A Hall-effect vane switch mounted on the distributor pick-up, is used to provide the firing signal for spark plugs, and also replaces traditional points. Four ferrous metal teeth, (one for each cylinder) located on a rotor inside the distributor cap, break the magnetic field at the sensor to provide a signal pattern equivalent to the firing of each cylinder. A harness connects the vane switch to the "black box" containing the remainder of the electronic ignition system.

MARKET

Automotive